

การไฟฟ้าฝ่ายผลิตแห่งประเทศไทย

REGISTRATION FORM

INVITATION TO BID NO. RTS2-S-10

FOR SUPPLY AND CONSTRUCTION OF 115 KV KHON KAEN 1 SUBSTATION (GIS)
AND IMPROVEMENT OF 115 KV KHON KAEN 2 SUBSTATION
TRANSMISSION SYSTEM EXPANSION AND RENOVATION PROJECT PHASE 2

FIRE PROTECTION SYSTEM PHASE 3

AVAILABLE DURATION FOR PURCHASING August 21, 2019 TO September 30, 2019

PRICE USD 256.- OR THB 8,000.-

COMPLETE DATA IS REQUIRED FOR THE BIDDER'S OWN BENEFITS

(โปรดกรอกรายละเอียดให้ครบถ้วนเพื่อประโยชน์ของบริษัท)

Step 1 : Fill out this Registration Form in English (Typing is preferred)

Step 2 : Submit this form for payment at Receivable Cashier Section (1st Floor, TOR 100 Bldg., Counter 4-8) Tel no. 02 436 5512

Step 3 : Bring the payment receipt and the copy of filled-out Registration Form to receive the bidding documents at International Procurement Department - Transmission Segment (Room No. 1202/2, 12th Floor, Building Tor. 101) Tel no. 02 436 0241-42

FOR PURCHASER		TAX ID :	
NO.	RECEIPT NO. :	DATE :	PURCHASER (ผู้ซื้อ):
BIDDER'S NAME (บริษัทผู้ซื้อเอกสาร)			
ADDRESS (ที่อยู่)		COUNTRY :	
ATTN. (ผู้รับผิดชอบ):		FAX NO.:	TEL.:
E-mail :			
LOCAL REPRESENTATIVE (ตัวแทนในประเทศ)			
ADDRESS (ที่อยู่)		TAX ID :	
ATTN. (ผู้รับผิดชอบ):		FAX NO.:	TEL.:
E-mail :			
FOR PROCUREMENT OFFICER		CHANGE OF BIDDER'S NAME	TAX ID :
BIDDER'S LETTER NO. :		DATED :	
NEW BIDDER'S NAME (ชื่อผู้ซื้อเอกสารเปลี่ยนเป็น)			
ADDRESS (ที่อยู่)		COUNTRY :	
ATTN. (ผู้รับผิดชอบ):		FAX NO.:	TEL.:
E-mail :			
LOCAL REPRESENTATIVE (ตัวแทนในประเทศ)			
ADDRESS (ที่อยู่)		TAX ID :	
ATTN. (ผู้รับผิดชอบ):		FAX NO.:	TEL.:
E-mail :			
FOR PROCUREMENT OFFICER		FOR PURCHASER	
Procurement Officer (ผู้ส่งมอบเอกสาร)		Document received by (ผู้รับมอบเอกสาร)	



INVITATION TO BID NO. RTS2-S-10
SUPPLY AND CONSTRUCTION OF 115 kV KHON KAEN 1 SUBSTATION (GIS)
AND IMPROVEMENT OF 115 kV KHON KAEN 2 SUBSTATION
TRANSMISSION SYSTEM EXPANSION AND RENOVATION PROJECT PHASE 2
FIRE PROTECTION SYSTEM PHASE 3

The Electricity Generating Authority of Thailand (EGAT) is calling for the subject Invitation to Bid to be financed by EGAT's fund. The escalation factor (K) for price adjustment is applied to this Bid.

Place of Construction : Khon Kaen 1 Substation and Khon Kaen 2 Substation

Medium Cost (including Value Added Tax and other expenses) : THB 695,000,000.-

Eligibility of Bidders

1. The Bidder shall be a juristic person who provides such services and shall not be named in the List of Work Abandoners published by the Office of Prime Minister and/or in the Debarment List and/or in the List of Work Abandoners declared by EGAT.
2. The Bidder shall not be a Jointly Interested Bidder with other Bidders as from the date of EGAT's issuance of the Invitation, or shall not be a person who undertakes any action as an "Obstruction of Fair Price Competition" for this Invitation.
3. The Bidder shall not either be EGAT's consultant or involve in EGAT's consultancy company under this Invitation to Bid, or shall not have EGAT's personnel involved in his business as shareholder having voting right that can control his business, director, manager, officer, employee, agent, or consultant except those who are officially ordered by EGAT to act or participate therein.
4. The Bidder shall not be the person who is privileged or protected not to be taken any legal proceedings under Thai Court; Provided that such Bidder's government declares that such special privilege is waived.
5. The Bidder who is a joint venture or consortium shall carry out all the work under such formation from the time of bidding until the fulfillment of the Contract.

Availability of Bidding Documents

Bidding Documents in CD-ROM will be available for examination of Bidder's Qualifications and purchase during 8:00 hrs. to 15:00 hrs., Bangkok Standard Time, as from August 21, 2019 to September 30, 2019 at USD 256.- or THB 8,000.- per copy, non-refundable, at the following address :

International Procurement Department - Transmission Segment
(Room No. 1202/2, 12th Floor, Building Tor. 101)
Procurement and Inventory Management Division
Electricity Generating Authority of Thailand
Bangkruai, Nonthaburi 11130, Thailand
Telephone no. 66 2436 0342
E-mail : procurement.tse@egat.co.th

For more details and downloading Registration Form for purchasing Bidding Documents on website : <http://www4.egat.co.th/fprocurement/biddingeng/>

Nilanate Osotparapust

Payment can be made by a certified cheque or money order payable to EGAT or by a telegraphic transfer to EGAT's current account no. 109-6-01958-2 (swift code : KRTHTHBK), Krung Thai Bank Public Company Limited, Bangkruai Branch, Nonthaburi. All bank charges and fees incurred by the payment of bidding documents shall be under the buyer's responsibility.

Bidding Documents in CD-ROM will be either airmailed or airfreighted to the buyer at EGAT's expense upon receipt of the relevant remittance. In case the buyer requires the Bidding Documents to be sent by Express Mail Service (EMS), the charge will be at the buyer's expense.

Delivery of Bids

Bids shall be submitted at Room No. 1202/1, 12th Floor, Building Tor. 101 during 9:30 hrs. to 10:00 hrs., Bangkok Standard Time, November 5, 2019 and will be opened publicly at 10:00 hrs.

ELECTRICITY GENERATING AUTHORITY OF THAILAND

August 14, 2019

Nilanate Osotpavapusit

(Mrs. Nilanate Osotpavapusit)

Chief, International Procurement Department -
Transmission Segment



ประกาศการไฟฟ้าฝ่ายผลิตแห่งประเทศไทย เรื่อง ประกวดราคาจ้าง เลขที่ RTS2-S-10

การไฟฟ้าฝ่ายผลิตแห่งประเทศไทย (กฟผ.) มีความประสงค์จะจัดหาและจ้างก่อสร้างสถานีไฟฟ้าแรงสูง 115 kV ขอนแก่น 1 (GIS) และจัดหาและจ้างปรับปรุงสถานีไฟฟ้าแรงสูง 115 kV ขอนแก่น 2 โครงการปรับปรุงและขยายระบบส่งไฟฟ้าที่เสื่อมสภาพตามอายุการใช้งานระยะที่ 2 และแผนงานติดตั้งระบบดับเพลิงสถานีไฟฟ้าแรงสูง ระยะที่ 3 โดยทำสัญญาแบบปรับราคาได้ (ค่า k) โดยใช้งบประมาณ กฟผ.

สถานที่ก่อสร้าง : สถานีไฟฟ้าแรงสูงขอนแก่น 1 และสถานีไฟฟ้าแรงสูงขอนแก่น 2

ราคากลาง (รวมภาษีมูลค่าเพิ่มและค่าใช้จ่ายอื่นๆ) : 695,000,000.- บาท

คุณสมบัติของผู้เสนอราคา

1. ต้องเป็นนิติบุคคลผู้มีอาชีพรับจ้างตามประกวดราคาจ้างดังกล่าว และต้องไม่เป็นผู้ทำงานซึ่งสำนักนายกรัฐมนตรีได้แจ้งเวียนชื่อไว้ หรือต้องไม่เป็นผู้ที่ กฟผ. ห้ามติดต่อหรือห้ามเข้าเสนอราคา หรือต้องไม่เป็นผู้ที่ได้รับผลของการสั่งให้นิติบุคคลหรือบุคคลอื่นเป็นผู้ทำงานตามคำสั่ง กฟผ.
2. ต้องไม่เป็นผู้มีผลประโยชน์ร่วมกันกับผู้เสนอราคารายอื่น ณ วันประกาศประกวดราคาครั้งนี้เป็นต้นไป หรือต้องไม่เป็นผู้กระทำการอันเป็นการขัดขวางการแข่งขันราคาอย่างเป็นธรรมในการดำเนินการประกวดราคาครั้งนี้
3. ต้องไม่เป็นที่ปรึกษาของ กฟผ. หรือมีส่วนร่วมในบริษัทที่ปรึกษาของ กฟผ. ในงานนี้ หรือต้องไม่มีผู้ปฏิบัติงาน กฟผ. เข้าไปมีส่วนร่วมในกิจการของผู้เสนอราคา ไม่ว่าจะในฐานะผู้ถือหุ้นที่มีสิทธิควบคุมการจัดการ กรรมการ ผู้อำนวยการ ผู้จัดการ พนักงาน ลูกจ้าง ตัวแทนหรือที่ปรึกษา ยกเว้น ในกรณีที่ผู้ปฏิบัติงานได้รับคำสั่งอย่างเป็นทางการจาก กฟผ. ให้ไปปฏิบัติงานหรือเข้าร่วมในกิจการของผู้เสนอราคา
4. ต้องไม่เป็นผู้ได้รับเบาะสิทธิ์หรือความคุ้มกัน ซึ่งอาจปฏิเสธไม่ยอมขึ้นศาลไทย เว้นแต่รัฐบาลของผู้เสนอราคาได้มีคำสั่งให้สลະสิทธิ์และความคุ้มกันเช่นนั้น
5. ผู้ประสงค์เข้าประกวดราคาในนามของกิจการร่วมค้าหรือกิจการค้าร่วม (Joint Venture or Consortium) จะต้องดำเนินการทุกขั้นตอนของการประกวดราคา ในนามของกิจการร่วมค้าหรือกิจการค้าร่วม ตั้งแต่การเสนอราคาจนสิ้นสุดข้อผูกพันกับ กฟผ.

การขายเอกสารประกวดราคา

ผู้สนใจติดต่อขอทราบรายละเอียด เพื่อตรวจสอบคุณสมบัติของผู้เสนอราคา และขอซื้อเอกสารประกวดราคา ในราคาชุดละ 8,000.- บาท ได้ที่ แผนกจัดจ้างต่างประเทศสายงานระบบส่ง (ห้อง 1202/2 ชั้น 12 อาคาร ท.101) กองจัดซื้อจัดจ้างต่างประเทศสายงานระบบส่ง ฝ่ายจัดซื้อจัดจ้างและบริหารพัสดุ การไฟฟ้าฝ่ายผลิตแห่งประเทศไทย เชียงสะพานพระราม 7 จังหวัดนนทบุรี ในวันทำการระหว่างเวลา 08:00 น. ถึง 15:00 น. ตั้งแต่วันที่ 21 สิงหาคม 2562 ถึงวันที่ 30 กันยายน 2562 หรือสอบถามทางโทรศัพท์ หมายเลข 0 2436 0342 หรืออีเมลล์ procurement.tse@egat.co.th ทั้งนี้ สามารถ download แบบฟอร์มลงทะเบียนผู้ซื้อเอกสารประกวดราคาได้ที่เว็บไซต์ <http://www4.egat.co.th/fprocurement/biddingeng/>

การยื่นซองประกวดราคา

กำหนดยื่นซองประกวดราคา ในวันที่ 5 พฤศจิกายน 2562 เวลา 9:30 น. ถึง 10:00 น. และเปิดซองประกวดราคา เวลา 10:00 น. ณ ห้อง 1202/1 ชั้น 12 อาคาร ท.101 การไฟฟ้าฝ่ายผลิตแห่งประเทศไทย เชียงสะพานพระราม 7 จังหวัดนนทบุรี

ประกาศ ณ วันที่ 14 สิงหาคม 2562

นิพนธ์ โสภณภักดิ์

(นางนิลเนตร โสภณภักดิ์)

หัวหน้ากองจัดซื้อจัดจ้างต่างประเทศสายงานระบบส่ง

ตารางแสดงวงเงินงบประมาณที่ได้รับจัดสรรและราคากลาง(ราคาอ้างอิง)
ในการจัดซื้อจัดจ้างที่มีชิ้นงานก่อสร้าง

1. ชื่อโครงการ ประกวตราคาเลขที่ RTS2-S-10

งานจัดหาและจ้างก่อสร้างสถานีไฟฟ้าแรงสูง 115 kV ขอนแก่น 1 (GIS)
และจัดหาและจ้างก่อสร้างปรับปรุงสถานีไฟฟ้าแรงสูง 115 kV ขอนแก่น 2
โครงการปรับปรุงและขยายระบบส่งไฟฟ้าที่เสื่อมสภาพตามอายุการใช้งานระยะที่ 2
และแผนงานติดตั้งระบบดับเพลิงสถานีไฟฟ้าแรงสูง ระยะที่ 3

/หน่วยงานเจ้าของโครงการ ฝ่ายแผนงานและโครงการระบบส่ง การไฟฟ้าฝ่ายผลิตแห่งประเทศไทย

2. วงเงินงบประมาณที่ได้รับจัดสรร

โครงการปรับปรุงและขยายระบบส่งไฟฟ้าที่เสื่อมสภาพตามอายุการใช้งานระยะที่ 2
งบประมาณ 21,900 ล้านบาท
แผนงานติดตั้งระบบดับเพลิงสถานีไฟฟ้าแรงสูง ระยะที่ 3 งบประมาณ 1,274.22 ล้านบาท

3. วันที่กำหนดราคากลาง 21 มิถุนายน 2562 (วันที่ รวส. อนุมัติ)

ราคารวมภาษีมูลค่าเพิ่มและค่าใช้จ่ายอื่นๆ เป็นเงิน 695,000,000.00 บาท ราคา/หน่วย ตามเอกสารแนบ

4. แหล่งที่มาของราคากลาง

หลักเกณฑ์การกำหนดราคากลางการจัดซื้อและจัดจ้างงานก่อสร้างระบบส่งไฟฟ้าของสายงานระบบส่ง

5. รายชื่อเจ้าหน้าที่ผู้กำหนดราคากลาง

- | | |
|---------------------------------|---------------|
| 5.1 นายฉัตรชัย เขาวนาธิคม | หมฟ-ส. กวอ-ส. |
| 5.2 นายธิติววัฒน์ เบญจวงศ์รัตน์ | ทสก-ส. กวอ-ส. |
| 5.3 นายภานุวัฒน์ ลิขิตผลผดุง | ทอท-ส. กวอ-ส. |
| 5.4 นายสุริยะ ปรุงขวัญเมือง | ทวอ-ส. กวอ-ส. |
| 5.5 นายเมธา รักปาน | กวป-ส. |
| 5.6 นางรรมภา สุนทรินทุ | กวธ-ส. |
| 5.7 นางอุบลรัตน์ ต้นเกิด | กวส-ส. อรส. |

หมายเหตุ ค่าใช้จ่ายอื่นๆ ได้แก่ ค่าใช้จ่ายที่ กฟผ. ต้องจ่ายตามวิธีการพิจารณาเปรียบเทียบราคาที่กำหนดไว้ในเอกสารประกวดราคา เช่น อากรขาเข้า เป็นต้น

นางสาววัลลภา ชิวณาณณ์กุล
ทจตส-ท.

14 ส.ค. 2562

MEDIUM COST FOR BID NO. RTS2-S-10

SUMMARY OF BID PRICE

SUPPLY AND CONSTRUCTION OF 115 KV KHON KAEN 1 SUBSTATION (GIS) AND IMPROVEMENT OF 115 KV KHON KAEN 2 SUBSTATION
TRANSMISSION SYSTEM EXPANSION AND RENOVATION PROJECT PHASE 2 AND
FIRE PROTECTION SYSTEM PHASE 3

Schedule	Description	Currency	Supply of Equipment		Local Currency (excluding VAT) Baht Amount	Local Transportation (excluding VAT) Baht Amount	Local Transportation, Construction and Installation (excluding VAT) Baht Amount
			Foreign Supply	Local Supply			
			CIF Thai Port	Ex-works Price (excluding VAT) Baht			
			Amount	Amount			
1	115 KV KHON KAEN 1 SUBSTATION (GIS)	THB	239,233,622.14	160,003,806.50	145,624,744.40	267,697.51	70,273,771.40
2	115 KV KHON KAEN 2 SUBSTATION			5,061,663.00			822,264.02
3	115 KV KHON KAEN 1 SUBSTATION (GIS) (FIRE PROTECTION SYSTEM PHASE 3)				23,303,359.68		
BID PRICE		THB	239,233,622.14	Baht 165,065,469.50	Baht 168,928,104.08	Baht 267,697.51	Baht 71,096,035.42
OTHER EXPENSES		THB	4,784,672.44	XXXXX	XXXXX	XXXXX	XXXXX
VAT		THB	17,081,280.62	Baht 11,554,582.87	Baht 11,824,967.29	Baht 18,738.83	Baht 4,976,722.48
SUMMARY OF BID PRICE		THB	261,099,575.20	Baht 176,620,052.37	Baht 180,753,071.37	Baht 286,436.34	Baht 76,072,757.90
TOTAL MEDIUM COST		THB			694,831,893.18		
TOTAL MEDIUM COST (ROUND)		THB			695,000,000.00		

Schedule 1, 2 and 3 are related schedules referring to Article F-15. Liquidated Damages for Late Completion and Late Delivery, item a. For Complete Construction of Substation.

**MEDIUM COST FOR BID NO. RTS2-S-10
 SCHEDULE 1 : 115 KV KHON KAEN 1 SUBSTATION (GIS)
 SUPPLY AND CONSTRUCTION OF 115 KV KHON KAEN 1 SUBSTATION (GIS)
 TRANSMISSION SYSTEM EXPANSION AND RENOVATION PROJECT PHASE 2**

Description	Currency	Supply of Equipment		Local Currency (excluding VAT) Baht Amount	Local Transportation (excluding VAT) Baht Amount	Local Transportation, Construction and (excluding VAT) Baht Amount
		Foreign Supply	Local Supply			
		CIF Thai Port	Ex-works Price (excluding VAT) Baht			
		Amount	Amount			
PART 1AB : SUPPLY AND INSTALLATION OF SUBSTATION EQUIPMENT	THB	238,013,919.74	155,869,314.50			70,273,771.40
PART 1C : CIVIL WORK				145,624,744.40		
PART 1D : SUPPLY OF SPARE PARTS	THB	1,219,702.40	2,825,088.00		202,229.51	
PART 1E : WORK ON SUPPLY EQUIPMENT BASIS			1,309,404.00		65,468.00	
TOTAL PRICE	THB	239,233,622.14	Baht 160,003,806.50	Baht 145,624,744.40	Baht 267,697.51	Baht 70,273,771.40

MEDIUM COST FOR BID NO. RTS2-S-10
PART 1AB : SUPPLY AND INSTALLATION OF SUBSTATION EQUIPMENT
SUPPLY AND CONSTRUCTION OF 115 KV KHON KAEN 1 SUBSTATION (GIS)
TRANSMISSION SYSTEM EXPANSION AND RENOVATION PROJECT PHASE 2

Description	Currency	Supply of Equipment		Local Transportation, Construction and (excluding VAT) Baht
		Foreign Supply	Local Supply	
		CIF Thai Port	Ex-works Price (excluding VAT) Baht	
		Amount	Amount	
Schedule 1AB1 : Power Transformer and Marshalling Control Cubicle			234,000.00	28,080.00
Schedule 1AB2 : Distribution Transformer			4,786,000.00	574,320.00
Schedule 1AB4 : Surge Arrester	THB	2,322,000.00	930,000.00	390,240.00
Schedule 1AB5 : Current Transformer and Junction Box	THB	990,000.00	100,000.00	130,800.00

นางสาววัลลภา ชีวนากรณ์กุล

ทจตส-ท.

MEDIUM COST FOR BID NO. RTS2-S-10
PART 1AB : SUPPLY AND INSTALLATION OF SUBSTATION EQUIPMENT
SUPPLY AND CONSTRUCTION OF 115 KV KHON KAEN 1 SUBSTATION (GIS)
TRANSMISSION SYSTEM EXPANSION AND RENOVATION PROJECT PHASE 2

Description	Currency	Supply of Equipment		Local Transportation, Construction and (excluding VAT) Baht Amount
		Foreign Supply	Local Supply	
		CIF Thai Port	Ex-works Price (excluding VAT) Baht	
		Amount	Amount	
Schedule 1AB6 : Coupling Capacitor Voltage Transformer, Coupling Capacitor, Voltage Transformer and Junction Box	THB	1,380,000.00	197,000.00	189,240.00
Schedule 1AB7 : SF6 Gas Insulated Switchgear	THB	193,906,296.00		23,268,755.52
Schedule 1AB10 : Disconnecting Switch	THB	1,276,000.00	118,342.40	167,321.09
Schedule 1AB11 : Power Fuse, Fuse Link and Hook Stick	THB	1,457,150.20		174,858.02

On
นางสาววัลลภา ชีวนาครณ์กุล

หงตส-ท.

14 ส.ค. 2562

Rev.24

- Project 1-1C3 -

filename : RTS2-S-10-1 (115kV KK1)

[Signature]
๑๙ ส.ค. ๖๒

MEDIUM COST FOR BID NO. RTS2-S-10
PART 1AB : SUPPLY AND INSTALLATION OF SUBSTATION EQUIPMENT
SUPPLY AND CONSTRUCTION OF 115 KV KHON KAEN 1 SUBSTATION (GIS)
TRANSMISSION SYSTEM EXPANSION AND RENOVATION PROJECT PHASE 2

Description	Currency	Supply of Equipment		Local Transportation, Construction and (excluding VAT) Baht
		Foreign Supply	Local Supply	
		CIF Thai Port	Ex-works Price (excluding VAT) Baht	
		Amount	Amount	
Schedule 1AB12 : AC&DC Distribution Board and Termination Box			5,863,219.00	703,586.28
Schedule 1AB13 : Stationary Battery and Battery Charger	THB	607,200.00	527,055.57	136,110.67
Schedule 1AB14 : Substation Steel Structure			4,406,128.93	1,321,838.68
Schedule 1AB15 : Insulator				60,717.69

Sm

นางสาววัลลภา ชิวาภรณ์กุล

ทจตส-ท.

14 ส.ค. 2562

Handwritten signature
14 25.62

MEDIUM COST FOR BID NO. RTS2-S-10
PART 1AB : SUPPLY AND INSTALLATION OF SUBSTATION EQUIPMENT
SUPPLY AND CONSTRUCTION OF 115 KV KHON KAEN 1 SUBSTATION (GIS)
TRANSMISSION SYSTEM EXPANSION AND RENOVATION PROJECT PHASE 2

Description	Currency	Supply of Equipment		Local Transportation, Construction and (excluding VAT) Baht
		Foreign Supply	Local Supply	
		CIF Thai Port	Ex-works Price (excluding VAT) Baht	
		Amount	Amount	
Schedule 1AB16 : Cable Terminations	THB	16,565,887.80		4,523,309.34
Schedule 1AB17 : XLPE Power Cable			64,787,976.00	16,196,994.00
Schedule 1AB18 : Low Voltage Cable and Conductor			34,830,750.24	8,707,687.56
Schedule 1AB19 : Switchyard Lighting Fixtures			981,779.70	294,533.91



นางสาววัลลภา ชิวขนาดรณ์กุล
 หจตส-ท.

14 ส.ค. 2562



24 ส.ค. 62

MEDIUM COST FOR BID NO. RTS2-S-10
PART 1AB : SUPPLY AND INSTALLATION OF SUBSTATION EQUIPMENT
SUPPLY AND CONSTRUCTION OF 115 KV KHON KAEN 1 SUBSTATION (GIS)
TRANSMISSION SYSTEM EXPANSION AND RENOVATION PROJECT PHASE 2

Description	Currency	Supply of Equipment		Local Transportation, Construction and (excluding VAT) Baht
		Foreign Supply	Local Supply	
		CIF Thai Port	Ex-works Price (excluding VAT) Baht	
		Amount	Amount	
Schedule 1AB20 : Aluminum Tube, Connector and Miscellaneous Hardware			161,829.36	40,457.34
Schedule 1AB21 : Bus Fitting	THB	512,376.78		128,094.20
Schedule 1AB22 : Grounding Material	THB	828,132.80	604,074.24	379,886.76
Schedule 1AB23 : Substation Miscellaneous	THB	41,007.16	261,413.06	75,605.06

นางสาววัลลภา ชีวนาครณ์กุล

ทจตส-ท.

14 ส.ค. 2562

Rev.24

- Project 1-1C6 -

Handwritten signature and date
24 ส.ค. 62

filename : RTS2-S-10-1 (115kV KK1)

MEDIUM COST FOR BID NO. RTS2-S-10
PART 1AB : SUPPLY AND INSTALLATION OF SUBSTATION EQUIPMENT
SUPPLY AND CONSTRUCTION OF 115 KV KHON KAEN 1 SUBSTATION (GIS)
TRANSMISSION SYSTEM EXPANSION AND RENOVATION PROJECT PHASE 2

Description	Currency	Supply of Equipment		Local Transportation, Construction and (excluding VAT) Baht
		Foreign Supply	Local Supply	
		CIF Thai Port	Ex-works Price (excluding VAT) Baht	
		Amount	Amount	
Schedule 1AB24 : Control and Protection System			32,033,842.00	3,282,877.00
Schedule 1AB25 : Fault Recording System			2,902,846.00	356,039.00
Schedule 1AB34 : 48 VDC Stationary Battery, Battery Charger and DC Power			1,108,000.00	75,000.00
Schedule 1AB35 : Communication Cable			859,160.00	1,532,020.00

On

นางสาววัลลภา ชีวธนาธรรมกุล

ทดตส-ท.

14 ส.ค. 2562

Handwritten signature and date
 24 ส.ค. 62

MEDIUM COST FOR BID NO. RTS2-S-10
PART 1AB : SUPPLY AND INSTALLATION OF SUBSTATION EQUIPMENT
SUPPLY AND CONSTRUCTION OF 115 KV KHON KAEN 1 SUBSTATION (GIS)
TRANSMISSION SYSTEM EXPANSION AND RENOVATION PROJECT PHASE 2

Description	Currency	Supply of Equipment		Local Transportation, Construction and (excluding VAT) Baht
		Foreign Supply	Local Supply	
		CIF Thai Port	Ex-works Price (excluding VAT) Baht	
		Amount	Amount	
Schedule 1AB37 : Medium Voltage Switchgear	THB	18,127,869.00		2,175,344.28
Schedule 1AB38 : Remote Terminal Unit			175,898.00	1,023,555.00
Schedule 1AB39 : Commissioning				4,280,000.00



นางสาววัลลภา ชีวธนากรณกุล
 หจตส-ท.

14 ส.ค. 2562



24. 8. 62

MEDIUM COST FOR BID NO. RTS2-S-10
PART 1AB : SUPPLY AND INSTALLATION OF SUBSTATION EQUIPMENT
SUPPLY AND CONSTRUCTION OF 115 KV KHON KAEN 1 SUBSTATION (GIS)
TRANSMISSION SYSTEM EXPANSION AND RENOVATION PROJECT PHASE 2

Description	Currency	Supply of Equipment		Local Transportation, Construction and (excluding VAT) Baht
		Foreign Supply	Local Supply	
		CIF Thai Port	Ex-works Price (excluding VAT) Baht	
		Amount	Amount	
Schedule 1AB40 : Installation of Equipment and Steel Structure Supplied by EGAT				56,500.00
PART 1AB	THB	238,013,919.74	Baht	70,273,771.40
			155,869,314.50	

 นางสาววัลลภา ชิวชนากรณ์กุล
 หจตส-ท.
 14 ส.ค. 2562

 24 ส.ค. 62

MEDIUM COST FOR BID NO. RTS2-S-10
PART 1C : CIVIL WORK
SUPPLY AND CONSTRUCTION OF 115 KV KHON KAEN 1 SUBSTATION (GIS)
TRANSMISSION SYSTEM EXPANSION AND RENOVATION PROJECT PHASE 2

Description	Local Currency (excluding VAT) Baht	Local Transportation, Construction and (excluding VAT) Baht
	Amount	Amount
Schedule 1C1 : Foundation Work	5,598,850.00	
Schedule 1C2 : Cable Trench	20,383,007.00	
Schedule 1C3 : Control Building	103,828,423.40	
Schedule 1C4 : Earth Work, Road and Crushed Rock Surfacing	2,404,077.00	
Schedule 1C5 : Water Supply System	66,952.00	
Schedule 1C6 : Drainage System	8,712,098.00	
Schedule 1C8 : Miscellaneous	4,631,337.00	
PART 1C	Baht 145,624,744.40	Baht



นางสาววัลลภา ชิวณากรณ์กุล

ทจตส-ท.

14 ส.ค. 2562



MEDIUM COST FOR BID NO. RTS2-S-10
PART 1D : SUPPLY OF SPARE PARTS
SUPPLY AND CONSTRUCTION OF 115 KV KHON KAEN 1 SUBSTATION (GIS)
TRANSMISSION SYSTEM EXPANSION AND RENOVATION PROJECT PHASE 2

Description	Currency	Supply of Equipment		Local Transportation (excluding VAT) Baht Amount
		Foreign Supply	Local Supply	
		CIF Thai Port	Ex-works Price (excluding VAT) Baht	
		Amount	Amount	
Schedule 1D7 : Spare Parts for SF6 Gas Insulated Switchgear	THB	557,808.00		27,890.40
Schedule 1D11 : Spare Parts for Power Fuse, Fuse Link and Hook Stick	THB	164,795.40		8,239.86
Schedule 1D12 : Spare Parts for AC&DC Distribution Board and Termination Box			268,986.00	13,449.30
Schedule 1D24 : Spare Parts for Control and Protection System			2,135,579.00	106,774.00

นางสาววัลลภา ชีวณาคณ์กุล
ทจตส-ท.

MEDIUM COST FOR BID NO. RTS2-S-10
PART 1D : SUPPLY OF SPARE PARTS
SUPPLY AND CONSTRUCTION OF 115 KV KHON KAEN 1 SUBSTATION (GIS)
TRANSMISSION SYSTEM EXPANSION AND RENOVATION PROJECT PHASE 2

Description	Currency	Supply of Equipment		Local Transportation (excluding VAT) Baht Amount
		Foreign Supply	Local Supply	
		CIF Thai Port	Ex-works Price (excluding VAT) Baht	
		Amount	Amount	
Schedule 1D25 : Spare Parts for Fault Recording System			420,523.00	21,021.00
Schedule 1D37 : Spare Parts for Medium Voltage Switchgear	THB	497,099.00		24,854.95
PART 1D	THB	1,219,702.40	Baht 2,825,088.00	Baht 202,229.51

นางสาววัลลภา ชีวณาคธรรมกุล
หจตส-น.
14 ส.ค. 2562

MEDIUM COST FOR BID NO. RTS2-S-10
PART 1E : WORK ON SUPPLY EQUIPMENT BASIS
SUPPLY AND CONSTRUCTION OF 115 KV KHON KAEN 1 SUBSTATION (GIS)
TRANSMISSION SYSTEM EXPANSION AND RENOVATION PROJECT PHASE 2

Description	Currency	Supply of Equipment		Local Transportation (excluding VAT) Baht Amount	Local Transportation, Construction and (excluding VAT) Baht Amount
		Foreign Supply	Local Supply		
		CIF Thai Port	Ex-works Price (excluding VAT) Baht		
		Amount	Amount		
Schedule 1E24 : Control and Protection System			1,309,404.00	65,468.00	
PART 1E			Baht 1,309,404.00	Baht 65,468.00	Baht



นางสาววัลลภา ชีวนาครณ์กุล
 หจตส-ท.
 14 ส.ค. 2562



**MEDIUM COST FOR BID NO. RTS2-S-10
 SCHEDULE 2 : 115 KV KHON KAEN 2 SUBSTATION
 IMPROVEMENT OF 115 KV KHON KAEN 2 SUBSTATION
 TRANSMISSION SYSTEM EXPANSION AND RENOVATION PROJECT PHASE 2**

Description	Currency	Supply of Equipment		Local Currency (excluding VAT) Baht Amount	Local Transportation (excluding VAT) Baht Amount	Local Transportation, Construction and Installation (excluding VAT) Baht Amount
		Foreign Supply	Local Supply			
		CIF Thai Port	Ex-works Price (excluding VAT) Baht			
		Amount	Amount			
PART 2AB : SUPPLY AND INSTALLATION OF SUBSTATION EQUIPMENT			5,061,663.00			822,264.02
TOTAL PRICE			Baht 5,061,663.00	Baht	Baht	Baht 822,264.02



นางสาววัลลภา ชีวนาครณ์กุล
 หจตส-ท.
 14 ส.ค. 2562



24 ส.ค. 62

MEDIUM COST FOR BID NO. RTS2-S-10
PART 2AB : SUPPLY AND INSTALLATION OF SUBSTATION EQUIPMENT
IMPROVEMENT OF 115 KV KHON KAEN 2 SUBSTATION
TRANSMISSION SYSTEM EXPANSION AND RENOVATION PROJECT PHASE 2

Description	Currency	Supply of Equipment		Local Transportation, Construction and Installation (excluding VAT) Baht
		Foreign Supply	Local Supply	
		CIF Thai Port	Ex-works Price (excluding VAT) Baht	
		Amount	Amount	
Schedule 2AB12 : AC&DC Distribution Board and Termination Box			154,971.00	18,596.52
Schedule 2AB18 : Low Voltage Cable and Conductor			1,476,970.00	369,242.50
Schedule 2AB24 : Control and Protection System			3,429,722.00	411,997.00
Schedule 2AB38 : Remote Terminal Unit				22,428.00
Schedule 2AB39 : Commissioning				
PART 2AB			Baht 5,061,663.00	Baht 822,264.02

นางสาววัลลภา ชิวขนาดณ์กุล
หจกส-ท.

MEDIUM COST FOR BID NO. RTS2-S-10
SCHEDULE 3 : 115 KV KHON KAEN 1 SUBSTATION (GIS) (FIRE PROTECTION SYSTEM PHASE 3)
SUPPLY AND CONSTRUCTION OF 115 KV KHON KAEN 1 SUBSTATION (GIS)
FIRE PROTECTION SYSTEM PHASE 3

Description	Currency	Supply of Equipment		Local Currency (excluding VAT) Baht Amount	Local Transportation (excluding VAT) Baht Amount	Local Transportation, Construction and Installation (excluding VAT) Baht Amount
		Foreign Supply	Local Supply			
		CIF Thai Port	Ex-works Price (excluding VAT) Baht			
		Amount	Amount			
PART 3C : CIVIL WORK				23,303,359.68		
TOTAL PRICE			Baht	Baht 23,303,359.68	Baht	Baht

 นางสาววัลลภา ชีวขนาดธน์กุล
 ทจตส-ท

14 ส.ค. 2562

 14 ส.ค. 62

MEDIUM COST FOR BID NO. RTS2-S-10
PART 3C : CIVIL WORK
SUPPLY AND CONSTRUCTION OF 115 KV KHON KAEN 1 SUBSTATION (GIS)
FIRE PROTECTION SYSTEM PHASE 3

Description	Local Currency (excluding VAT) Baht
	Amount
Schedule 3C7 : Special Construction Works	2,613,037.68
Schedule 3C9 : Fire Protection System	20,690,322.00
PART 3C	Baht 23,303,359.68

 นางสาววัลลภา ชิวณาธรรมกุล
 หจตส-ท
 14 ส.ค. 2562

 24 ส.ค. 62

Important Information
for
Invitation to Bid No. RTS2-S-10

The purpose of this section is to inform the Bidders to **carefully study** the details of the revised terms and conditions in the bidding documents. The following provisions have been **recently revised** as stated hereunder:

Article F-11. Payment:

If the Contractor requires the payment of foreign currency portion to be paid directly to the suppliers, he has to inform EGAT **which portion of the Contract Price, as stipulated in the term of payment of the Contract**, to be paid accordingly.

In case the local Contractor requires foreign currency or currencies to be paid directly to him, payment of such foreign currency or currencies will be made to the local Contractor in Thai Baht by using the **selling exchange rate** published by the Bank of Thailand on the **payment date** (previously stated as buying exchange rate on the bid opening date).

The number of days which payment for the first portion of foreign supply will be made after delivery, previously specified as 45 days, has been **deleted**.

Article F-15. Liquidated Damages for Late Completion and Late Delivery:

The limit of liquidated damages, previously specified that does not exceed 10%, has been **deleted**.

DATA SHEET

for

Invitation to Bid No. RTS2-S-10

This Section consists of provisions that are specific to each procurement and supplement the information or requirements included in Bidding Documents.

Article B-3. Bid Security

The amount of bid security shall be USD 1,120,740.- or THB 34,750,000.-.

Article F-15. Liquidated Damages for Late Completion and Late Delivery, item a. For Complete Construction of Substation,

If the Contractor fails to meet any of the completion dates for Schedule 1 : 115 kV Khon Kaen 1 Substation (GIS) or Schedule 2 : 115 kV Khon Kaen 2 Substation or Schedule 3 : 115 kV Khon Kaen 1 Substation (GIS) (Fire Protection System Phase 3), the liquidated damages shall be at the rate of one-tenth of one (0.10) per cent of the total Contract Price for Schedule 1 : 115 kV Khon Kaen 1 Substation (GIS) and Schedule 2 : 115 kV Khon Kaen 2 Substation and Schedule 3 : 115 kV Khon Kaen 1 Substation (GIS) (Fire Protection System Phase 3) for each Day of delay. This sum is payable regardless of the actual loss and/or damages incurred.

Maintenance Guarantee Period

- For all Work except 500 kV System

The Contractor shall guarantee the proper functioning of the Work for a period of one (1) Year except the following Equipment the guarantee period of which shall be as follows :

<u>Equipment</u>	<u>Period of Guarantee (Year)</u>
- Fault Recording System	2
- Control and Protection System	2

- For 500 kV System

The Contractor shall guarantee the proper functioning of the Work for a period of five (5) Years.

Defective Equipment to be replaced with the whole new set

Not Applicable

ELECTRICITY GENERATING AUTHORITY OF THAILAND

Nonthaburi
Thailand

INVITATION TO BID NO. RTS2-S-10

SUPPLY AND CONSTRUCTION OF 115 kV KHON KAEN 1 SUBSTATION (GIS) AND IMPROVEMENT OF 115 kV KHON KAEN 2 SUBSTATION

TRANSMISSION SYSTEM EXPANSION AND RENOVATION PROJECT PHASE 2 FIRE PROTECTION SYSTEM PHASE 3

Invitation

The Electricity Generating Authority of Thailand (EGAT) hereby invites sealed bids for supply and construction of 115 kV Khon Kaen 1 Substation (GIS) and Improvement of 115 kV Khon Kaen 2 Substation under Transmission System Expansion and Renovation Project Phase 2 and Fire Protection System Phase 3 as described herein in accordance with terms, conditions and Specifications described in these Bidding Documents.

Work Description

The supply and construction of 115 kV Khon Kaen 1 Substation (GIS) and Improvement of 115 kV Khon Kaen 2 Substation will be on a supply and construction basis, the Contractor shall be responsible for complete supply, installation, construction and also engineering design work to the standard specified and best modern practice. The substations to be constructed and the scope of work under this Invitation are described in Section H. Scope of Work.

Eligibility of Bidders: General Requirements

- I. All Bidders shall meet the following requirements; failure to so comply shall constitute sufficient ground for rejection.
 - a. The Bidder shall be a partnership, firm or company, either alone or in joint venture or in consortium.
 - b. The Bidder shall be well-established and maintain a permanent place of business.

- c. The Bidder shall not be, or supply the Equipment, from the country under the state of Civil War.
- d. The Bidder shall be a juristic person who manufactures or provides such material or services, as the case may be, and not be named in the List of Work Abandoners published by the Office of Prime Minister and/or in the Debarment List and/or in the List of Work Abandoners declared by EGAT.
- e. The Bidder shall not be a Jointly Interested Bidder with other Bidders as from the date of EGAT's issuance of the Invitation to Bid, or shall not be a person who undertakes any action as an "Obstruction of Fair Price Competition" as defined in Additional Regulation for this Invitation.
- f. The Bidder shall not either be EGAT's consultant or involving in EGAT's consultancy company under this Invitation, or have EGAT's personnel involved in his business as shareholder having voting right that can control his business, director, manager, officer, employee, agent or consultant except for the ones who are officially ordered by EGAT to act or participate therein.
- g. The Bidder shall not be the person who is privileged or protected not to be taken any legal proceeding under Thai Court; provided that such Bidder's government declares that such special privilege is waived.
- h. In case of a joint venture or consortium, the Bidder shall carry out all the work under such formation from the time of bidding until the fulfillment of the Contract.
- i. ***The Bidder shall be a purchaser of the bidding documents from EGAT. For a joint venture or consortium, only one (1) member of the joint venture or consortium is required to purchase the bidding documents.***

In the case where the Bidder is not the purchaser of the bidding documents, the purchaser shall notify EGAT of the name of the Bidder in writing prior to the bid opening.

- II. All Bidders should preferably meet the following requirements; failure to so comply may constitute sufficient ground for rejection.
 - a. The Bidder shall have adequate fund to meet financial obligations incidental to this Contract.
 - b. The Bidder shall supply documentary evidence established in accordance with Article B-8. Information to be Submitted with Bid to demonstrate adequately that he is eligible to bid and is qualified to perform the Contract if his bid is accepted. Bidder should also demonstrate his capacity to perform the Work either with or without the use of subcontractor.

Eligibility of Bidders: Technical Requirements

I. All Bidders shall meet the following requirements; failure to so comply shall constitute sufficient ground for rejection.

- a. Being well-established and maintaining a permanent place of business.

If the Bidder is a new company formed by acquisition of or merger with other companies or business units before submitting the Bid, the experience records of any of such previous companies or business units that meet the requirements set forth herein are acceptable as the experience records of the Bidder.

If Bidder is a new company formed by acquisition of or merger with other companies or business units, the pending claim of any of such previous companies or business units shall be considered pending claim of the Bidder.

Reference records of either the parent or affiliated companies shall not be considered as the record of such Bidder.

- b. The Bidder shall have one of the following qualifications regarding experiences executing contract of supply and construction substation.

- 1) Having experience with EGAT in executing at least one (1) contract as contractor (not as subcontractor) for supply and construction of a complete 115 kV or above conventional or GIS substation, with its overall performance satisfactory to EGAT;
- 2) Having experience in executing at least two (2) contracts as contractor (not as subcontractor) for supply and construction of 115 kV or above conventional or GIS substation with other Electricity Authorities of Thailand or in an overseas country (not his own country).

Experience record of the Bidder or either member of the joint venture /consortium, including experience record derived from being a member of other joint venture or consortium in previous project(s) is acceptable. It is not allowed to combine the experience records of each member of the joint venture/consortium in order to meet the experience requirements.

- c. Further to b.1) and b.2) mentioned above, having a record of experience within the last ten (10) years on the technical knowledge and practical experience on design, construction and installation of Equipment of a 115 kV or above complete conventional or GIS substation. Bidder shall also demonstrate his capacity to perform Work.

Experience record of the Bidder or either member of the joint venture /consortium, including experience record derived from being a member of other joint venture or consortium in previous project(s) is acceptable, provided that there is a letter from the project owner certifying that the Works as described in c. above were performed by the Bidder or either member of the joint venture/ consortium of this project. It is not allowed to combine the experience records of each member of the joint venture/consortium in order to meet the experience requirements.

With respect to item b. and c. above, reference records of either the parent or affiliated companies of the Bidder or of either member of joint venture or consortium shall not be acceptable. If the Bidder has previously formed as the joint venture/consortium with other company and the experience record(s) of the joint venture/consortium meet(s) the requirement set forth herein, such experience record(s) of the joint venture/consortium is(are) also acceptable as the experience record(s) of the Bidder.

d. The Bidder shall propose Equipment manufactured by the qualified manufacturers who shall fulfill the following requirements :

1. Regularly manufacturing of Equipment of the type and similar ratings proposed.
2. Being well-established and maintaining a permanent place of business.
3. The manufacturer shall have the experience records that meet the requirements set forth herein.

Reference records of either parent or affiliated companies shall not be considered as the records of such manufacturer.

4. If the Manufacturer is a new company formed by acquisition of or merger with other companies or business units, and any of such previous companies or business units has the experience records that meet the requirements set forth herein, such experience records are acceptable as the experience records of the new company, provided that each item of the equipment to be supplied under this bid shall be manufactured from the same source of supply as indicated in each of such relevant supply records as described in Item I.d.5 to I.d.6 below. Otherwise, it shall not be acceptable and shall be sufficient grounds for rejection.

For the avoidance of doubt, it is not allowed to combine the experience records of the previous companies or business units in order to meet the experience requirements.

5. For 115 kV Ratings of Gas-Insulated Switchgear (GIS). These Equipment shall be manufactured by the qualified manufacturers who shall fulfill the following requirements :

5.1 Having one of the following qualifications:

- 5.1.1 Proposing the Equipment of the type and ratings which has already been accepted by EGAT.

OR

- 5.1.2 Having a supply record of Equipment of the type proposed (*type of enclosure, interrupter of circuit breaker, rated filling gas pressure*) at the nominal system voltage of 110 kV or above, busbar current of 2000 A or above, 40 kA or above, with successful operation/use of at least three (3) consecutive years in an overseas country (not his own country) and at least three (3) substations of which total GIS bays shall not be less than twelve (12).

However, the Equipment of the type and short circuit current ratings proposed shall have a supply record of successful operation/use of at least three (3) consecutive years in an overseas country (not his own country) and at least one (1) substation of which total GIS bays shall not be less than four (4).

In case that the supply record of Equipment of the type and ratings proposed fulfills the requirement, the manufacturer may propose a newly developed or modified type of such Equipment with successful operation/use of at least three (3) substations of which total GIS bays shall not be less than twelve (12) and having minimum one (1) year in an overseas country (not his own country). The detailed information of the development or modification shall be submitted with his proposal. EGAT, however, reserves the right and will make its own judgment whether or not to consider or accept the proposed developed or modified type.

5.2 Having a past design test record of the Equipment as proposed, if specified in EGAT's specification. Such past design test record shall conform to the test specified in EGAT's specification.

6. For Control and Protection System, having the following qualifications:

6.1 Being local manufacturer.

6.2 Having one of the following qualifications :

6.2.1 Having a supply record of successful operation/use in EGAT's or other Electricity Authorities of Thailand's 110 kV or above Transmission System for at least three (3) consecutive years and at least three (3) units of each type of Protective Relay Panels having similar characteristics to the ones specified herein.

OR

6.2.2 Having a letter of acceptance for manufacturing and/or fabrication of the specific Equipment issued by EGAT within the scope specified therein.

II. All Bidders should preferably meet the following technical requirements; failure to so comply may constitute sufficient ground for rejection.

- a. The Bidder shall have sufficient capacity to carry out the work.
- b. The Bidder shall have no just or proper claims pending against him with respect to breach in the performance of Contract on other similar works awarded by EGAT. In case the Bidder is a joint venture/consortium, either member of the joint venture/consortium shall have no just or proper claims pending against him with respect to breach in the performance of Contract on other similar works awarded by EGAT.

- c. The Bidder himself or his subcontractors, at the time of submitting this proposal, shall not carry excessive work nor be in a default position with respect to work with EGAT. Unsatisfactory past performance on Contract awarded by EGAT may be a sufficient reason of being disqualified.
- d. The Bidder shall propose Equipment from manufacturers who fulfill the requirements below. If there is any deficiency, EGAT reserves the right to require the Bidder to propose new manufacturer or new type/model of Equipment without any additional cost to EGAT.
 1. Regularly manufacturing of Equipment of the type and similar ratings proposed.
 2. Being well-established and maintaining a permanent place of business
 3. The manufacturer shall have the experience records that meet the requirements set forth herein.

Reference records of either parent or affiliated companies shall not be considered as the records of such manufacturer.

4. If the Manufacturer is a new company formed by acquisition of or merger with other companies or business units, and any of such previous companies or business units has the experience records that meet the requirements set forth herein, such experience records are acceptable as the experience records of the new company, provided that each item of the equipment to be supplied under this bid shall be manufactured from the same source of supply as indicated in each of such relevant supply records as described in Item II.d.5 thru II.d.15 below.

For the avoidance of doubt, it is not allowed to combine the experience records of the previous companies or business units in order to meet the experience requirements.

5. For 115 kV Ratings of Power Circuit Breaker shall be manufactured by the qualified manufacturers who shall fulfill the following requirements :
 - 5.1 Having one of the following qualifications :
 - 5.1.1 Proposing the Equipment of the type and ratings which has already been accepted by EGAT.
 - OR
 - 5.1.2 Having a supply record of Equipment of the type proposed at nominal system voltage of 110 kV or above, 2000 A or above, 40 kA or above, with successful operation/use of at least three (3) consecutive years in an overseas country (not his own country) and at least three (3) three phase sets.

However, the Equipment of the type and short circuit current ratings proposed shall have a supply record of successful operation/use of at least three (3) consecutive years in an overseas country (not his own country) and at least one (1) three phase set.

In case that the supply record of Equipment of the type and ratings proposed fulfilled the requirement, the manufacturer may propose a newly developed or modified type of such Equipment with successful operation/use for at least one (1) year in an overseas country (not his own country) and at least three (3) three phase sets. The detailed information of the development or modification shall be submitted with his proposal. EGAT, however, reserves the right and will make its own judgment whether or not to consider or accept the proposed developed or modified type.

5.2 Having a past design test record of the Equipment as proposed, if specified in EGAT's specification. Such past design test record shall conform to the test specified in EGAT's specification.

6. For 115 kV Ratings of following Equipment: Instrument Transformer, Surge Arrester and Disconnecting Switch. These Equipment shall be manufactured by the qualified manufacturers who shall fulfill the following requirements :

6.1 Having one of the following qualifications :

6.1.1 Proposing the Equipment of the type and ratings which has already been accepted by EGAT.

OR

6.1.2 Having a supply record of Equipment of the type and ratings proposed with successful operation/use of at least three (3) three-phase sets and having minimum three (3) consecutive years in an overseas country (not his own country).

In case that the supply record of Equipment of the type and ratings proposed fulfills the requirement, the manufacturer may propose a newly developed or modified type of such Equipment with successful operation/use of at least three (3) three-phase sets and having minimum one (1) year in an overseas country (not his own country). The detailed information of the development or modification shall be submitted with his proposal. EGAT, however, reserves the right and will make its own judgment whether or not to consider or accept the proposed developed or modified type.

Supply records of the higher rating Equipment shall not be considered if the Bidder does not propose such higher rating Equipment in his bid.

6.2 Having a past design test record of the Equipment as proposed, if specified in EGAT's specification. Such past design test record shall conform to the test specified in EGAT's specification.

7. For 33, 22 and 11 kV ratings of following Equipment : Metal-Clad SF₆ Gas Insulated Switchgear, Power Circuit Breaker, Instrument Transformer, Disconnecting Switch and Surge Arrester

Having one of the following qualifications :

- 7.1 Proposing the Equipment of the type and ratings which has already been accepted by EGAT.

OR

- 7.2 Having a supply record of Equipment of the type and ratings proposed with successful operation/use of at least three (3) consecutive years in an overseas country (not his own country) and at least three (3) three phase sets. The ratings and features of Equipment shall be the same or similar rating as EGAT specifies.

In case that the supply record of Equipment of the type and ratings proposed fulfilled the requirement, the manufacturer may propose a newly developed or modified type of such Equipment with successful operation/use of at least one (1) year in an overseas country (not his own country) and at least three (3) three phase sets. The detailed information of the development or modification shall be submitted with his proposal. EGAT, however, reserves the right and will make its own judgment whether or not to consider or accept the proposed developed or modified type.

Supply records of the higher rating Equipment shall not be considered if the Bidder does not propose such higher rating Equipment in his bid.

8. For Distribution Transformer, Power Fuse, AC&DC Distribution Board and Lighting Relay Panel (LRP), Load Center Unit Substation (LCUS), Junction Box, Battery Charger, Substation Steel Structure, 33 kV and below Cable Terminations, XLPE Power Cable, Power Cable, Control Cable and Switchboard Wire, Lighting Cable, Copper Ground Wire, Overhead Ground Wire, Aluminum Conductor, Optical Fiber Cable, Switchyard Lighting Fixtures, Aluminum Tube, Compression Connector and Miscellaneous Hardware, Bus Fittings, Ground Rod, Thermite Welding Material, Grounding Hardware, Conduit and Conduit Fittings

- 8.1 Being local manufacturer for the following Equipment :

Distribution Transformer, AC&DC Distribution Board and Lighting Relay Panel (LRP), Load Center Unit Substation (LCUS), Junction Box, Battery Charger, Substation Steel Structure, 115 kV and below XLPE Power Cable, Power Cable, Control Cable and Switchboard Wire, Lighting Cable, Copper Ground Wire, Overhead Ground Wire, Aluminum Conductor, Single mode optical fiber cable, Switchyard Lighting Fixtures, Aluminum Tube, Compression Connector and Miscellaneous Hardware, Thermite Welding Material and Conduit.

8.2 Having been granted a licence for producing standard product by Thai Industrial Standard Institute (TISI), Ministry of Industry for the following Equipment:

60 kV through 115 kV XLPE Power Cable, Lighting cable and Aluminum conductor.

8.3 Having one of the following qualifications :

8.3.1 Having supply record of Equipment of the type and similar ratings proposed with successful operation/use for at least one (1) year.

OR

8.3.2 Having a letter of acceptance for manufacturing and/or fabrication of the specific Equipment issued by EGAT within the scope specified therein (For the local manufacturer).

9. For Insulator

Having one of the following qualifications :

9.1 Having supply record with successful operation/use for at least three (3) consecutive years in an overseas country (not his own country) and for following equipment :

9.1.1 Suspension Insulator, at least 10,000 units having the similar ANSI class as proposed.

9.1.2 Station Post Insulator, having the similar ANSI technical reference number as proposed.

OR

9.2 Having a letter of acceptance for manufacturing and/or fabrication of the specific Equipment issued by EGAT within the scope specified therein (For the local manufacturer).

10. For Stationary Battery

Having one of the following qualifications :

10.1 Having supply record of Equipment of the type and similar ratings proposed with successful operation/use in substations/switchyards of at least three (3) consecutive years and at least three (3) sets.

In case that the supply record of Equipment of the type and similar ratings proposed fulfilled the requirements, the manufacturer may propose a newly developed or modified type of such Equipment with successful operation/use of at least one (1) year. The detailed information of the development or modification shall be submitted with his proposal. EGAT, however, reserves the right and will make its own judgement whether or not to consider or accept the proposed developed or modified type.

OR

10.2 Having a letter of acceptance for manufacturing and/or fabrication of the specific Equipment issued by EGAT within the scope specified therein (For the local manufacturer).

11. For above 33kV through 115 kV Outdoor Type Cable Termination and Cable Termination for GIS.

Having one of the following qualifications :

11.1 Proposing the Equipment of the type and ratings which have ever been accepted by EGAT.

OR

11.2 Having a supply record of Equipment of the type and ratings proposed with successful operation/use for at least three (3) consecutive years in an overseas country (not his own country) and at least five (5) three phase sets. The ratings and features of Equipment shall be the same or similar rating as EGAT specifies.

In case that the supply record of Equipment of the type and ratings proposed fulfilled the requirement, the manufacturer may propose a newly developed or modified type of such Equipment with successful operation/use for at least one (1) year in overseas country (not his own country) and at least five (5) three phase sets. The detailed information of the development or modification shall be submitted with his proposal. EGAT, however, reserves the right and will make its own judgment whether or not to consider or accept the proposed developed or modified type.

Supply records of the higher rating Equipment shall not be accepted if the Bidder does not propose such higher rating Equipment in his bid.

12. Proposing the protective relay from the manufacturers as listed in EGAT's Specifications and shall be in compliance with the details specified in EGAT's Specifications. Type/Model of the main protective relays proposed shall be as specified in EGAT ACCEPTED MAIN RELAY LIST NO.1 and NO.2 attached at the end of Section A. Invitation to Bid.

13. For Fault Recording System.

13.1 Having one of the following qualifications :

13.1.1 The cabinet and all equipment is completely wired by the manufacturer before shipping to Thailand.

OR

13.1.2 The cabinet and the equipment are wired in Thailand by the manufacturer that has obtained special permission from EGAT for manufacturing and/or fabrication of the Control and Protection System within the scope specified in the Letter of Permission which is issued by EGAT (for the local manufacturer). The design and engineering shall be performed by the FRS's manufacturer. The assembly, factory test and commissioning shall be in accordance with the

FRS's manufacturer standard and performed under the manufacturer's supervisor.

13.2 The Fault Recording System (FRS) proposed shall be in compliance with the details specified in EGAT's Specifications. Manufacturer/type/model of FRS proposed shall be as specified in EGAT ACCEPTED FAULT RECORDING SYSTEM LIST attached at the end of Section A. Invitation to Bid

14. Being local manufacturer for steel supporting structure of Instrument Transformer, Surge Arrester and Disconnecting Switch.

15. For Closed-circuit television (CCTV) system and equipment

15.1 Proposed camera and Network Video Recorder (NVR) manufacturer shall have a representative or a branch office of manufacturer in Thailand for at least ten (10) years.

15.2 Proposed brand of IP cameras shall have a supply record of IP cameras for at least five hundred (500) IP cameras per contract with successful operation/use for at least three (3) years in Thailand.

15.3 The bidder or subcontractor shall have one of the following qualifications:

15.3.1 Having experiences in installation and cabling of outdoor-type IP cameras for at least fifty (50) cameras per contract with successful operation/use for at least three (3) years in Thailand.

OR

15.3.2 Having experiences in optical fiber cabling in substation switchyards for at least five (5) substations per contract with successful operation/use for at least three (3) years in Thailand.

15.4 Being local manufacturer for the following Equipment: CCTV Rack cabinet, Monitoring desk, CCTV pole, 12-core ADSS optical fiber cable.

e. Proposing the manufacturer who has no just or proper claims pending against Equipment of the same type/model to be proposed under this bid.

In case the manufacturer is a new company formed by acquisition or merger with other companies or business units, the pending claim of any of such previous companies or business units shall be considered pending claim of the manufacturer.

f. Proposing reputable subcontractors, for the portion of the work to be subcontracted, having adequate technical knowledge, ability and capacity to perform such work and having at least three years experience in the performance of similar work and of equal magnitude to the work to be subcontracted. If any proposed subcontractor(s) is (are) not qualified in the opinion of EGAT, the Bidder is required to select other subcontractor(s) at his own cost to the satisfaction of EGAT.

EGAT ACCEPTED MAIN RELAY LIST No.1

Scheme	Technique	Accepted Type/Model	Manufacturer	Acceptance for			Notes
				500kV	230kV	115&69kV	
Current Differential	Numerical	RED670	ABB	YES	YES	YES	Only software version 1.1 is accepted.
		P543	GE	YES	YES	YES	The manufacturer's name "ALSTOM" is changed to "GE"
		L90	GE	YES	YES	YES	
		SEL-311L	SEL	YES	YES	YES	
		7SD52	Siemens	YES	YES	YES	
		GRL100	Toshiba	YES	YES	YES	
		P543	Schneider Electric	YES	YES	YES	
		EF-LD	INGETEAM	YES	YES	YES	
		PCS-931	NR Electric	YES	YES	YES	
Distance Protection	Numerical	REL670	ABB	YES	YES	YES	Only software version 1.1 is accepted.
		P443	GE	YES	YES	YES	The manufacturer's name "ALSTOM" is changed to "GE"
		D30	GE		YES	YES	Only for three pole tripping and line protection that no need carrier scheme.
		D60	GE		YES	YES	
		ALPSDA1	GE	YES	YES	YES	
		SEL-311C	SEL			YES	Only for three pole tripping and line protection that no need carrier scheme.
		SEL-421	SEL	YES	YES	YES	For 21P, 85, 67N. The relay with auto-reclosing function can not be accepted.
		7SA522	Siemens	YES	YES	YES	
		7SA6 series	Siemens	YES	YES	YES	
		GRZ100	Toshiba		YES	YES	
		GRZ200	Toshiba		YES	YES	
		ZLV	ZIV		YES	YES	
		P443	Schneider Electric	YES	YES	YES	
		EF-ZT	INGETEAM	YES	YES	YES	
		PCS-902	NR Electric	YES	YES	YES	
Transformer Differential	Numerical	RET670	ABB	YES	YES	YES	Only software version 1.1 is accepted.
		RET650	ABB	YES	YES	YES	3-restraints.
		P64x	GE	YES	YES	YES	The manufacturer's name "ALSTOM" is changed to "GE"

EGAT ACCEPTED MAIN RELAY LIST No.1

Scheme	Technique	Accepted Type/Model	Manufacturer	Acceptance for			Notes
				500kV	230kV	115&69kV	
Transformer Differential	Numerical	T35	GE		YES	YES	
		T60	GE		YES	YES	
		Duobias	Siemens		YES	YES	The manufacturer's name "Reyrolle" is changed to "Siemens"
		SEL-387	SEL		YES	YES	4-restraints.
		SEL-487E	SEL	YES	YES	YES	
		SEL-587	SEL			YES	2-restraints.
		SEL-787	SEL			YES	2-restraints.
		7UT6	Siemens	YES	YES	YES	5-restraints.
		GRT100	Toshiba	YES	YES	YES	
		GRT200	Toshiba	YES	YES	YES	
		IDV	ZIV	YES	YES	YES	
		P645	Schneider Electric	YES	YES	YES	
		EF-TD	INGETEAM	YES	YES	YES	3-restraints.
		PCS-978	NR Electric	YES	YES	YES	
Busbar Protection	High Impedance	REB650	ABB	YES	YES	YES	
		SEL-587Z	SEL	YES	YES	YES	
		GRB150	Toshiba	YES	YES	YES	
Busbar Protection	Numerical Low Impedance	REB670	ABB	YES	YES	YES	Only software version 1.1 is accepted.
		REB500	ABB	YES	YES	YES	
		P746	GE	YES	YES	YES	The manufacturer's name "ALSTOM" is changed to "GE"
		P740	GE	YES	YES	YES	The manufacturer's name "ALSTOM" is changed to "GE"
		B90	GE	YES	YES	YES	
		B30	GE	YES	YES	YES	Only use in case that the bus arrangement is Breaker-and-a-half, Double-bus-Double-Breaker or Main-and-Transfer.
		P747	GE	YES	YES	YES	
		SEL-487B	SEL	YES	YES	YES	
		7SS52	Siemens	YES	YES	YES	
7SS60	Siemens	YES	YES	YES	Only use in case that the bus arrangement is Breaker-and-a-half, Double-bus-Double-Breaker or Main-and-Transfer.		

EGAT ACCEPTED MAIN RELAY LIST No.1

Scheme	Technique	Accepted Type/Model	Manufacturer	Acceptance for			Notes
				500kV	230kV	115&69kV	
Busbar Protection	Numerical Low Impedance	7SS85	Siemens	YES	YES	YES	
		GRB100	Toshiba	YES	YES	YES	
		P746	Schneider Electric	YES	YES	YES	
		P740	Schneider Electric	YES	YES	YES	
Breaker Failure Protection	Numerical	RAHB411	ABB	YES	YES	YES	
		REQ650	ABB			YES	
		P141	GE	YES	YES	YES	3-phase Breaker failure function only. The manufacturer's name "ALSTOM" is changed to "GE"
		P14Nx	GE	YES	YES	YES	The manufacturer's name "ALSTOM" is changed to "GE"
		C60	GE		YES	YES	
		F60	GE		YES	YES	
		SEL-501	SEL	YES	YES	YES	3-phase Breaker failure function only.
		P821	Schneider Electric		YES	YES	Only firmware version 1.F is accepted.
		7VK6 series	Siemens	YES	YES	YES	The function and the operating time for each system shall be conform to Specification nos. 1005 and 1002.
		GRC100	Toshiba		YES	YES	
		GRD200	Toshiba	YES	YES	YES	
		EF-ZT	INGETEAM	YES	YES	YES	
		PCS-9611	NR Electric	YES	YES	YES	3-phase Breaker failure function only.

Note

- The procedures for being listed in EGAT ACCEPTED MAIN RELAY LIST can be requested from Transmission System Engineering Division.
- If any type of relay in the list is planned not to be manufactured, the manufacturer or the representative is responsible for informing EGAT at least 1 year before it is obsolete.
- The relays shall be configured to comply with all EGAT's needed functions.

EGAT ACCEPTED MAIN RELAY LIST No.2

Scheme	Technique	Accepted Type/Model	Manufacturer	Acceptance for				Notes
				500kV	230kV	69&115kV	22&33kV	
Directional Overcurrent Relay	Numerical	REQ650	ABB	YES	YES	YES	YES	
		P14Dx	GE	YES	YES	YES	YES	The manufacturer's name "ALSTOM" is changed to "GE"
		P841	GE	YES	YES	YES	YES	The manufacturer's name "ALSTOM" is changed to "GE"
		SEL-351A	SEL	YES	YES	YES	YES	
		SEL-451	SEL	YES	YES	YES	YES	
		SEL-751	SEL	YES	YES	YES	YES	
		GRE140	Toshiba	YES	YES	YES	YES	
		GRD200	Toshiba	YES	YES	YES	YES	
		7SJ62	Siemens	YES	YES	YES	YES	
		7SJ85	Siemens	YES	YES	YES	YES	
		IRV	ZIV		YES	YES	YES	
		EF-MD	INGETEAM	YES	YES	YES	YES	
		PCS-9611	NR Electric				YES	None of line fault locator. Only use with feeder.
Overcurrent Relay	Numerical	REQ650	ABB	YES	YES	YES	YES	
		P141	GE	YES	YES	YES	YES	The manufacturer's name "ALSTOM" is changed to "GE"
		P14Dx	GE	YES	YES	YES	YES	The manufacturer's name "ALSTOM" is changed to "GE"
		P14Nx	GE	YES	YES	YES	YES	The manufacturer's name "ALSTOM" is changed to "GE"
		P841	GE	YES	YES	YES	YES	The manufacturer's name "ALSTOM" is changed to "GE"
		F60	GE	YES	YES	YES	YES	
		F650	GE	YES	YES	YES	YES	
		SR350	GE	YES	YES	YES	YES	
		P120	Schneider Electric	YES	YES	YES	YES	

EGAT ACCEPTED MAIN RELAY LIST No.2

Scheme	Technique	Accepted Type/Model	Manufacturer	Acceptance for				Notes
				500kV	230kV	69&115kV	22&33kV	
Overcurrent Relay	Numerical	P122	Schneider Electric	YES	YES	YES	YES	
		SEL-351A	SEL	YES	YES	YES	YES	
		SEL-451	SEL	YES	YES	YES	YES	
		SEL-551	SEL	YES	YES	YES	YES	
		SEL-751	SEL	YES	YES	YES	YES	
		SEL-751A	SEL	YES	YES	YES	YES	
		7SJ61	Siemens	YES	YES	YES	YES	
		7SJ62	Siemens	YES	YES	YES	YES	
		7SJ85	Siemens	YES	YES	YES	YES	
		GRE140	Toshiba	YES	YES	YES	YES	
		GRD200	Toshiba	YES	YES	YES	YES	
		IRV	ZIV		YES	YES	YES	
		EF-MD	INGETEAM	YES	YES	YES	YES	
		PCS-9611	NR Electric	YES	YES	YES	YES	3 pole trip only
Synchronism Check Relay	Numerical	REQ650	ABB	YES	YES	YES		
		SPAU140C	ABB	YES	YES	YES		
		P841	GE	YES	YES	YES		The manufacturer's name "ALSTOM" is changed to "GE"
		F60	GE	YES	YES	YES		
		F650	GE	YES	YES	YES		
		SEL-279H	SEL	YES	YES	YES		
		SEL-351A	SEL	YES	YES	YES		
		SEL-451	SEL	YES	YES	YES		
		SEL-751	SEL	YES	YES	YES		
		SEL-751A	SEL	YES	YES	YES		
		7VK61	Siemens	YES	YES	YES		
		7SJ85	Siemens	YES	YES	YES		
		GRD200	Toshiba	YES	YES	YES		

EGAT ACCEPTED MAIN RELAY LIST No.2

Scheme	Technique	Accepted Type/Model	Manufacturer	Acceptance for				Notes
				500kV	230kV	69&115kV	22&33kV	
Synchronism Check Relay	Numerical	EF-MD	INGETEAM	YES	YES	YES		
		PCS-9611	NR Electric	YES	YES	YES		
	Static	RASC	ABB	YES	YES	YES		only use in Interposing Panel.
Auto Reclosing Relay	Numerical	REQ650	ABB	YES	YES	YES		
		P841	GE	YES	YES	YES		The manufacturer's name "ALSTOM" is changed to "GE"
		F60	GE		YES	YES		3 pole reclose only
		F650	GE		YES	YES		3 pole reclose only
		DRS	GE		YES	YES		3 pole reclose only
		SEL-279H	SEL		YES	YES		3 pole reclose only
		SEL-351A	SEL		YES	YES		3 pole reclose only
		SEL-451	SEL		YES	YES		3 pole reclose only
		SEL-751	SEL		YES	YES		3 pole reclose only
		7VK512	Siemens	YES	YES	YES		
		7VK61	Siemens	YES	YES	YES		
		GRR100	Toshiba	YES	YES	YES		
		GRD200	Toshiba	YES	YES	YES		
		EF-ZT	INGETEAM	YES	YES	YES		
		PCS-9611	NR Electric		YES	YES		3 pole reclose only
Overfluxing Relay	Static	RALK	ABB	YES	YES	YES		
	Numerical	7RW600	Siemens	YES	YES	YES		
		EF-TD	INGETEAM	YES	YES	YES		
Frequency Relay	Numerical	P94Vx	GE	YES	YES	YES	YES	The manufacturer's name "ALSTOM" is changed to "GE"
		MIV	GE		YES	YES	YES	
		SEL-351A	SEL	YES	YES	YES	YES	
		SEL-451	SEL	YES	YES	YES	YES	
		SEL-751	SEL	YES	YES	YES	YES	

EGAT ACCEPTED MAIN RELAY LIST No.2

Scheme	Technique	Accepted Type/Model	Manufacturer	Acceptance for				Notes
				500kV	230kV	69&115kV	22&33kV	
Frequency Relay	Numerical	SEL-751A	SEL	YES	YES	YES	YES	
		7SJ85	Siemens	YES	YES	YES	YES	
		EF-MD	INGETEAM	YES	YES	YES	YES	
		PCS-9611	NR Electric	YES	YES	YES	YES	
Under/Overvoltage Relay	Numerical	MIV	GE		YES	YES	YES	
		P94V	GE	YES	YES	YES	YES	None of VT input (open delta connection) for 59N.
		SEL-351A	SEL	YES	YES	YES	YES	
		SEL-751	SEL	YES	YES	YES	YES	
		SEL-751A	SEL	YES	YES	YES	YES	
		7SJ62	Siemens	YES	YES	YES	YES	
		7SJ85	Siemens	YES	YES	YES	YES	
		GRD200	Toshiba	YES	YES	YES	YES	
		IRV	ZIV	YES	YES	YES	YES	
		EF-MD	INGETEAM	YES	YES	YES	YES	
		PCS-9611	NR Electric		YES	YES	YES	C-Bank protection only

Note

- The procedures for being listed in EGAT ACCEPTED MAIN RELAY LIST can be requested from Transmission System Engineering Division.
- If any type of relay in the list is planned not to be manufactured, the manufacturer or the representative is responsible for informing EGAT at least 1 year before it is obsolete.
- The relays shall be configured to comply with all EGAT's needed functions.

EGAT ACCEPTED FAULT RECORDING SYSTEM LIST

Accepted Type/Model	Manufacturer
IDM+	QUALITROL
M871	GE
7KE85	SIEMENS
TESLA 4000	ERL Phase
TR2100	Rochester (RIS)

Note

- The procedures for being listed in EGAT ACCEPTED FAULT RECORDING SYSTEM LIST can be obtained from Transmission System Engineering Division.
- If any type of FRS in the list is planned not to be manufactured, the manufacturer or the representative is responsible for informing EGAT at least 1 year before it is obsolete.



EGAT ACCEPTED MANUFACTURER LIST FOR PROTECTIVE RELAY

Description	Manufacturer / Country
Protective Relay	ABB / Sweden, Switzerland, USA
	GE / USA, Canada, Spain, UK
	SEL / USA
	Siemens / Germany
	Reyrolle / UK
	Toshiba / Japan, Vietnam
	Schneider Electric / France, UK
	ZIV / Spain
	INGETEAM / Spain
	NR Electric / China
	Mitsubishi / Japan

EGAT ACCEPTED MANUFACTURER LIST FOR FAULT RECORDING SYSTEM

Description	Manufacturer / Country
Fault Recording System	Qualitrol / UK
	Siemens / Germany
	Rochester / USA
	GE / USA
	ERL Phase / Canada

๕๕

tse
เอกสารควบคุม

SECTION H
SCOPE OF WORK

SCOPE OF WORK

H-1. General

<u>No.</u>	<u>Substation</u>	<u>Page</u>
1.	115 kV KHON KAEN 1 SUBSTATION (KK1) (JOB NO. RTS2-01-S08)	H1-1
2.	KHON KAEN 2 SUBSTATION (KK2) (JOB NO. RTS2-03-S35)	H2-1
3.	KHON KAEN 1 SUBSTATION (KK1) (FIRE PROTECTION SYSTEM PHASE 3) (JOB NO. FPS2-01-S17)	H3-1

1. 115 kV KHON KAEN 1 SUBSTATION (KK1) (JOB NO. RTS2-01-S08)

General

Khon Kaen 1 Substation is located at Tambon Nai Mueang, Amphoe Mueang, Khon Kaen Province. The new 115 kV Gas Insulated switchgear (GIS) substation is replaced the existing 115 kV conventional substation. The new 115 kV Gas Insulated switchgear (GIS) is Breaker & A Half scheme. During the new 115 kV Gas Insulated switchgear (GIS) construction, the existing 115 kV conventional substation shall be operated.

Schedule 1

Sixteen (16) Feeders of Breaker & A Half scheme at the new 115 kV GIS shall be provided for transmissions lines and autotransformers as follows :

- Two (2) feeders for 115 kV Lines No. 1 & 2 to Nam Phong 1
- Two (2) feeders for 115 kV Lines No. 1 & 2 to Phon
- Four (4) feeders for 115 kV Lines No. 1, 2, 3 & 4 to Khon Kaen 2
- Two (2) feeders for 115 kV Lines No. 1 & 2 to PEA
- Three (3) feeders for 200 MVA, 230/115-22 kV auto-transformers "KT3A, KT4A & KT5A"
(Plug-in 115kV XLPE cable 2x1/C 800 Sq.mm. per phase)
- Three (3) feeders for 50 MVA, 115/22-11 kV power transformers "KT1A, KT2A & KT6A"

The Contractor shall supply equipment, perform construction and installation work necessary for completion of operation substation in accordance with the Contract Documents. The design work shall include, but not limited to, technical calculation, preparation of drawings, bill of materials for installation and construction work. For accomplishment of complete operational substation, Scope of Contractor's work shall include connection to all public utilities i.e. electrical power, water and drainage. Testing and commissioning of all equipment required to make the substation function properly.

Besides, all detailed engineering design work, calculations, drawing preparation, submission of backup data, test reports instruction books (and) , etc. shall be included.

1) As stated elsewhere in these bidding documents, the drawings included in the bidding documents except drawing mark "For Construction" are for bidding purposes only and shall not be used for execution of the work.

2) The submitted drawings which are incomplete/unacceptable, or are the bidding document copies with minor modifications shall be returned unmarked to the Contractor.

3) The drawings shall be furnished which provide all details required for thoroughly described equipment as well as installation methods and requirements. However, EGAT retains the right to request additional details if those furnished are perceived inadequate.

4) Calculations, backup data and documentation are required for all parts of the design. The furnished data shall verify completely that design is adequate for application purpose.

Work included in this Contract. The Work included in this Contract to be performed by the Contractor shall be as specified in the Contract Documents and as follows:

For Electrical Work

115 kV Gas Insulated Switchgear (GIS)

1. Design, supply and installation of equipment required for a complete the new 115 kV GIS, 22 kV switchgear and 22 kV-400/230 V power supply system.
2. Design, supply and installation of miscellaneous hardware required for the following :
 - 2.1 The connection between the existing 230 kV substation & the new 115 kV substation
 - 2.2 The connection of the new 115 kV GIS cable interface to 200 MVA 230/115-22 kV auto-transformers (KT3A, KT4A & KT5A)
 - 2.3 The connection of the new 115 kV GIS air bushings to 115 kV overhead lines
 - 2.4 The connection of the new 115 kV GIS air bushings to 50 MVA 115/22-11 kV power transformers (KT1A, KT2A & KT6A)
 - 2.5 The connection of the 50 MVA 115/22-11 kV power transformers (KT1A, KT2A & KT6A) to the 22 kV switchgear
 - 2.6 The grounding equipment and miscellaneous hardware for 50 MVA, 115/22-11 kV power transformers (KT1A, KT2A & KT6A)
3. To meet EGAT's service continuity requirements, the GIS gas compartment can be designed as indicated in the single line diagram or can be designed differently under a condition that the design of the gas compartment shall fulfill the requirements as specified in the Specification.
4. Supply and installation of the marking pins for the referenced positions from the main bus shall be provided in the GIS building. The positions of the marking pins shall be

shown on the drawings for future GIS extension and the quantity shall be not less than 3 sets. The making pins shall be made of brass or stainless steel that have the formation as follows :

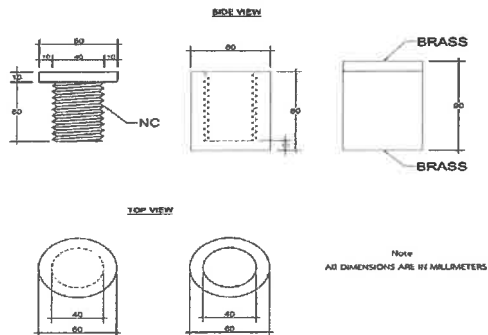

5. The GIB shall not be installed in multiple stacks for the purpose of convenient maintenance.
6. The detachable walk way (Cat walk) for visual inspection shall be properly installed on each GIS module and removable service platform, removable ladder shall be provided for GIS inspection.
7. The feeder nameplates as well as phasing, device, and switching numbers shown on the GIS module shall be painted or mounted (detachable type) on the enclosure of GIS whichever is appropriate according to the instruction from EGAT GIS installation team.
8. The sag and tension of phase wires and overhead ground wires shall be calculated and designed according to internationally-accepted standards by the Contractor and the said calculation shall be submitted to EGAT for approval.
9. Design, supply and installation of 115 kV XLPE cable system which comprises at least the following :
 - 9.1 The design and calculation of the 115 kV cable system shall conform to IEC or IEEE standards.
 - 9.2 The 115 kV XLPE cable shall be single-core with copper conductor.
 - 9.3 Design, supply and installation of the 115 kV XLPE cables in an 115 kV system complete from one end at the 115 kV GIS to the other end, including cable trenches, cable supporting structures, cable spacers, cable riser supporting structures, cable terminations, miscellaneous hardware, link box, SVL (if applicable) and all related equipment, structures, and hardware.

9.4 The 115 kV XLPE cable shall be installed in trefoil formation as follows :

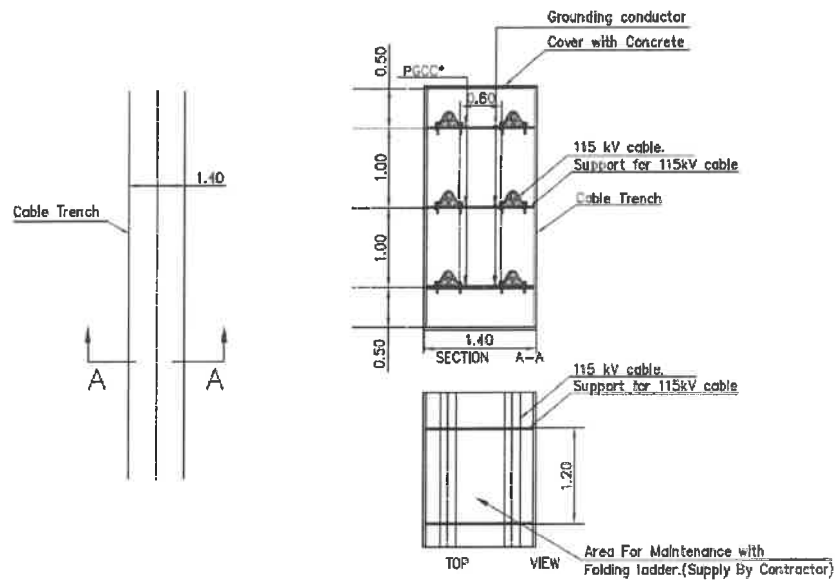

NOT TO SCALE

*PGCC : PARALLEL GROUND CONTINUITY CONDUCTOR (IF REQUIRED)

- The cable supporting structure shall be made of stainless steel, aluminum alloy or galvanized steel. The contractor shall design, supply and install the cable supporting structures that are suitable for cable cleat and cable system installation, and their grounding.
- 9.5 For calculation of forces caused by short-circuit currents, the peak short circuit current of **100 kA** shall be used.
- 9.6 The minimum bending radius of the 115 kV XLPE cable shall be checked by Contractor for cable installation and cable trench design.
- 9.7 The Contractor shall design the 115 kV cable system such that one (1) 1/C-800 Sq.mm. XLPE cable shall be able to carry the continuous current no less than **600 A** given that the ambient temperature is no less than 45°C and the effect of solar heat shall be considered. The other parameters used in the design shall be practical, reasonable, operational and conform to IEC or IEEE standards. The calculated continuous current rating shall be shown in the single-line diagram.
- 9.8 The Contractor shall design and select the type of metallic screen bonding. The induced voltage measured in every point of the metallic screen of 115 kV

XLPE cables shall be less than 60 V or shall conform to the IEC or IEEE standards' calculation.

- 9.9 Design, supply and installation the equipment to protect the power cable from the surge and over-voltage.
 - 9.10 The abnormal condition which occurs from the design and installation of 115 kV XLPE cables for example ferroresonance etc. shall be responsible by the Contractor.
10. Design, supply and installation of 22 kV XLPE cable system which comprises at least the following :
- 10.1 The design and calculation of the 22 kV cable system shall conform to IEC or IEEE standards.
 - 10.2 The 22 kV XLPE cable shall be single-core with copper conductor.
 - 10.3 Design, supply and installation of the 22 kV XLPE cables in a 22 kV system complete from one end at the 22 kV bus to the 22 kV switchgear, station service transformers (KW2AA & KW6AA) and EGAT living area transformers (KW1AA, KW1AB, KW2AB & KW6AB), including cable trench, cable supporting structures, cable spacers, cable cleats, cable termination supporting structures, cable terminations, miscellaneous hardware, link box, SVL (if applicable) and all related equipment. The cable cleats shall be metallic hot dip galvanized.
 - 10.4 The 22 kV XLPE cable shall be installed in trefoil formation as follows :

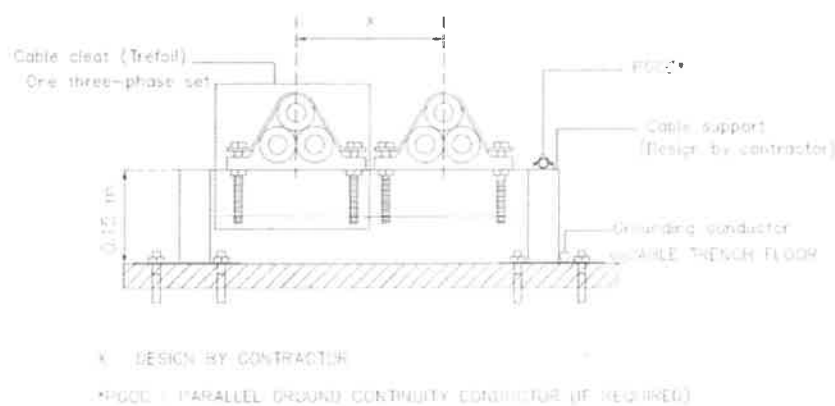

The cable supporting structure shall be made of stainless steel, aluminum alloy or galvanized steel. The contractor shall design, supply and install the cable

supporting structures that are suitable for cable cleat and cable system installation, and their grounding.

- 10.5 For calculation of forces caused by short-circuit currents, the peak short circuit current of **62.5 kA** shall be used.
- 10.6 The minimum bending radius of the 22 kV XLPE cable shall be checked by Contractor for cable installation and cable trench design.
- 10.7 The Contractor shall design the 22 kV cable system such that one (1) 1/C-500 Sq.mm. & 1/C-35 Sq.mm. XLPE cable shall be able to carry the continuous current no less than **700 A & 50 A** respectively given that the ambient temperature is no less than 45 °C and the effect of solar heat shall be considered. The other parameters used in the design shall be practical, reasonable, operational and conform to IEC or IEEE standards. The calculated continuous current rating shall be shown in the single-line diagram.
- 10.8 The Contractor shall design and select the type of metallic screen bonding. The induced voltage measured in every point of the metallic screen of 22 kV XLPE cables shall be less than 60 V or shall conform to the IEC or IEEE standards' calculation.
- 10.9 Design, supply and installation the equipment to protect the power cable from the surge and over-voltage.
- 10.10 The abnormal condition which occurs from the design and installation of 22 kV XLPE cables for example ferroresonance etc. shall be responsible by the Contractor.

Station service system

11. Design, supply and installation of the station service system complete with integral accessories to provide the complete system operation. The station service system shall mainly consist of as follows :
 - 500 kVA, 22,000-400/230 V distribution transformer (KW2AA)
 - 500 kVA, 22,000-400/230 V distribution transformer (KW6AA)
 - Load Center Unit Substation (LCUS)
 - 22 kV drop-out fuses
 - 600 V, 800 A safety switches

- 22 kV equipment, and AC & DC distribution boards, stationary batteries, battery chargers, power cables, and all related equipment for the complete operation
12. Design, supply and installation of the EGAT living area system complete with integral accessories to provide the complete system operation. The station service system shall mainly consist of as follows :
- 500 kVA, 22,000-400/230 V distribution transformer (KW1AB)
 - 500 kVA, 22,000-400/230 V distribution transformer (KW6AB)
 - 250 kVA, 22,000-400/230 V distribution transformer (KW1AA)
 - 250 kVA, 22,000-400/230 V distribution transformer (KW2AB)
 - Outdoor main distribution board
 - 22 kV drop-out fuses
 - 600 V, 800 A safety switches
 - 600 V, 400 A safety switches
 - 22 kV equipment, power cables, and all related equipment for the complete operation
13. Design, supply and installation of equipment required for a complete 400/230 V power supply system.
14. Design, supply and installation of station service transformers (KW2AA, KW6AA) & EGAT living area transformers (KW1AA, KW1AB, KW2AB & KW6AB).
15. Design, supply and installation of emergency lighting system for the GIS with control & relay building in case of normal station service fails with the illuminance of 150 LUX for at least 3 hours as shown in figure below.
16. Design, supply and installation of the stationary battery, in which the battery is capable of delivering power to the control and protection for tripping all circuit breakers and emergency essential load for at least 8 hours if normal station service fails. The capacity of the battery shall be designed by Contractor which the considered factors that influence the capacity of battery shall be as follows :
- The temperature correction factor is 1.0
 - The design margin factor is 1.15
 - The aging factor is 1.25

In case of bus faults occurring on the last hour of battery power, the battery shall generate sufficient power for tripping all circuit breakers. The stationary battery shall

be designed and calculated in accordance with IEEE or other acceptable international standards. In addition, the size of the stationary battery shall be designed to support the operation of the new 115 kV GIS and future diameter as shown on the attached bidding document drawings. The calculation shall be submitted to EGAT for approval.

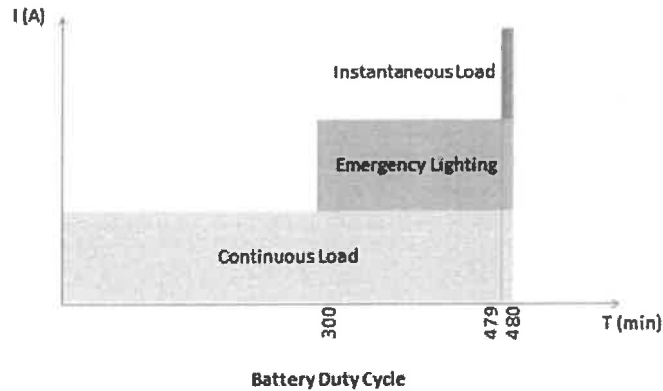

Grounding system

17. Design, supply and installation the grounding system of the 115 kV Substation grounding system including the grounding system of 115 kV GIS with control & relay building and 22 kV system.
18. The grounding conductor for the substation grounding system shall be of the 4/0 AWG bare copper wire type.
19. The ground grid conductors spacing under the building area shall be the same as the Switchyard.
20. Design, supply and installation of the grounding equipment and miscellaneous hardware for 230/115/22 kV system including the 22 kV power supply system and 115/22 kV XLPE cable system.
21. Design, supply and installation of the grounding system of the EGAT living area transformer. The grounding system of the EGAT living area transformer shall be separated from that of the substation.
22. The contractor shall evaluate the price of ground grid based on the specified design for price reference as below :
 - 22.1 The maximum ground grid conductor spacing (D_0) shall be 5 meters.
 - 22.2 The number of ground rod shall be 100 pieces.

23. The Contractor shall conduct the soil resistivity measurement. The result shall be submitted to EGAT for approval.
24. The Contractor shall design a grounding grid based on the measured soil resistivity by hand calculation using the equations in IEEE-80 standard and submitted to EGAT for Approval. The parameters for grounding system calculation shall be used as follows :
 - Fault current division factor (s_f) value = **1**
 - Fault current (rms) = **50 kA**
 - Time duration of fault = **1 second**

These parameters shall be used for determine the size of grounding conductor for the substation grounding system. If the ground conductor spacing calculated by hand (D_1) is less than the grounding conductor spacing for reference (D_0), the Contractor shall design a grounding grid by using the software. The certification of software shall be acceptable for commercial use.
25. The contractor shall connect the grounding grid between the new 115 kV GIS area and the existing 230 kV area **at least 3 points**.

Lightning protection

26. Design, supply and installation of the substation lightning protection system complete with all related equipment. The Contractor shall design the lightning protection system for the protection of all substation equipment which is under the protective zone. To meet EGAT's design criteria for the lightning protection system and to enhance the stability of lightning protection system, the Basic Insulation Level voltage (BIL) is to be used in calculation instead of Critical Flashover voltage (CFO) as follows:
 - 900 kV for 230 kV Substation
 - 550 kV for 115 kV Substation

For 22 kV Substation, the stroke current of 2 kA shall be used for the calculation
27. For the design of lightning protection system for the GIS building the lightning protection level (LPL) shall be used level 1 for calculation and the overhead ground wire is not permitted. Air terminal rods installed at the roof shall be used instead.
28. Lightning protection system shall be designed to meet IEC, NEMA and E.I.T. standards or internationally-accepted standards.

Facility system

29. Outdoor facility system

- 29.1 Design, supply and installation of a switchyard lighting system complete with all integral accessories to provide a complete system operation. The lighting system shall mainly consist of equipment lighting, fence lighting, access road lighting, power box (PRB), sign board lighting, lighting relay panel, raceways, and wiring cables for lighting circuits.
- 29.2 The lamps for outdoor facility lighting system shall be **LED** type with all integral accessories, e.g. lamp holders, fixtures, reflectors, and etc. The Contractor shall provide drawings that show details for installation.
- 29.3 Design, supply and installation of circuits for the main entrance gate. The control of the entrance gate shall be operated both manually and remote control which shall be controlled from the control room or the guardhouse.

30. Indoor facility system

- 30.1 Design, supply and installation of the facility system which mainly consists of lighting system, grounding system, power supply, fire alarm and protection system, and ventilation system, air-conditioning system, and telephone & LAN system in the 115 kV GIS with control & relay building. All cable wiring systems shall conform to NEC and IEC standards or internationally-accepted standards.
 - 30.2 The lamps for indoor facility lighting system shall be **LED** type with all integral accessories, e.g. lamp holders, fixtures, reflectors, and etc. The Contractor shall provide drawings that show details for installation and specify the LED lamp and LED luminaire circuit identified that the LED lamp circuit shall be supplied by 2 - 3 manufacturers. The power factor of the LED lamps shall be more than 0.9.
 - 30.3 All steel accessories e.g. lip-channel, conduit, conduit fittings, conduit accessories, box and cover shall be hot dip galvanized.
31. The size of low voltage cable shall be sufficient to keep the voltage drop at the load point less than **5%** at rated load current.
32. The voltage drop from the safety switch to the AC boards and from the AC boards to the load shall not exceed **3%** and **2%** respectively.

Telecommunication system

33. Design, supply and installation of the telecommunication tower installed on the roof deck of the 115 kV GIS with control & relay building. The telecommunication tower shall be constructed and divided into appropriate portions which are painted white and orange alternately with the top and bottom portions being painted orange. The obstruction lighting system shall be controlled by automatic flash box (AFB) that gives 30 - 60 flashes per minute. The AFB shall be turned on and turned off by a photo-light switch. The lightning protection system for the telecommunication tower shall be calculated and designed by the Contractor and the said calculation shall be submitted to EGAT for approval.

Others work

34. Supply and Installation of miscellaneous hardware required for suspension and station post insulators assembly.
35. Modification of Junction box supporting structure (JB003) for the installation of safety switch.
36. Modification of Junction box supporting structure (JB003) for the installation of outdoor receptacle box (ORB1, ORB3).
37. Modification of BS202 for installation of 22 kV XLPE cables and 22 kV power fuses.
38. Modification of TS702 for installation of station post insulators.
39. Modification of DP401 for installation of 22 kV XLPE cables and 22 kV disconnecting switches.
40. Design, supply and installation of cabling from the outdoor marshalling cubical (MC002) to the associated equipment.
41. Removal of the existing 115 kV take-off structures. Details of removal are shown on the bidding document drawings. All removed equipment shall be carefully packed by the Contractor and delivered to EGAT at Khon Kaen 3 Substation. Khon Kaen 3 Substation is located at Tumbon Ban Thum, Amphoe Mueang, Khon Kaen Province.
42. Relocation of wave traps (TY6A & TY7A) from the existing substation to the new 115 kV substation. Details of relocation are shown on the Bidding Document Drawing.

Testing and commissioning

43. Testing and commissioning of all equipment required to make the substation function properly.

Control and Protection System

For 230 kV KHON KAEN 1 Substation

44. Design, supply, installation, wiring, test and commissioning of the complete control and protection system which comprises of at least the following equipment :
 - Swing-rack type protective relay switchboards which shall be installed at the new 115 kV GIS Building. (These panels shall be interfaced to the existing control and protection systems, fault recording system and remote terminal unit at existing relay building)
 - OFC interfacing panel.
 - Cable and accessories as well as connection of cables among all the existing panels and the associated equipment in order to complete the function of the control and protection system.
45. Design, modification, wiring, test and commissioning of the existing equipment which comprises at least the following equipment in order to incorporate the new equipment:
 - The existing panels such as 400/230 VAC board, 125 VDC board, existing control and protection panels, marshalling panels (e.g. for the remote terminal unit, the fault recording system, teleprotection, control system ,etc.), interposing panel, transducer panel and fault recording system.
46. Design of the schematic and wiring diagrams of the additional inputs to the existing Computerized Control System (CCS). The test and commissioning of the completed CCS shall be performed by the Contractor.
47. The existing drawings shall be modified by the Contractor and submitted to EGAT for approval. The final drawings shall be submitted as ACAD files.
48. The Contractor shall be responsible for providing complete schematic and wiring diagrams of the control and protection system.
49. Removal of the unused existing cables. The removed cables shall be neatly reeled and kept in a suitable place recommended by EGAT.

For 115 kV KHON KAEN 1 Substation

50. Design, supply, installation, wiring, test and commissioning of the complete control and protection system which comprises of at least the following equipment:
- Swing rack type protective relay switchboards
 - Transducer panels
 - Interposing relay panels
 - Marshalling panels for the remote terminal unit
 - Marshalling panels for the fault recording system
 - Marshalling panels for the control system
 - Marshalling panels for the teleprotection
 - Fault Recording System
 - Metering panels
 - Outdoor antenna and GPS receiver Panel
 - OFC interfacing panel
 - EFLEX and/or HDPE Conduit with hot-dip galvanized steel clamp.
 - Loose equipment as specified in the price schedules.
 - 400/230 VAC, 125 VDC power panel and 125 VDC Power distribution boards.
 - Cables and accessories as well as connection of cables among all of the boards and the associated equipment in order to complete the function of the control and protection system.
51. Design, installation, wiring, test and commissioning of Remote Terminal Units (RTUs) and Master Station Unit which are supplied by EGAT. The configuration which is included in this Contract shall be fulfilled by the Contractor under EGAT's supervision.
52. Installation of the application software, database, control function and display for the Computerized Control System whereas the application software is supplied by EGAT. The installation shall be under EGAT's supervision.
53. The Contractor shall be responsible for providing complete schematic and wiring diagrams of the control and protection system.

Civil and Architectural Work

Architectural Work

54. Design and construction of

54.1 115 kV GIS and Control Building.

54.1.1 Structure & foundation. The proper structure can be selected for the design and construction and shall be submitted to EGAT for approval.

54.1.2 RC and/or steel structure for roof.

54.1.3 Fire protection for steel structure shall conform to legal provision, EGAT's specifications and Design manual for substation. Therefore, Fire protection for steel structure specification in Architecture drawing shall be cancelled.

54.1.4 Telecommunication tower structure (self-support) 6.00m installed on roof deck of GIS Building.

54.1.5 Architecture of the whole building.

54.1.6 The contractor shall construct the building in accordance with "IEEE STD- 979-1994 (R2004)" (IEEE Guide for Substation Fire Protection).

54.1.7 115 kV GIS and Control Building shall be designed with reference to Khon Kaen 1 Substation (Dwg. No. KK1-C-1)/ Dwg.No.KK1-GIS-7-01A. But equipment layouts and cable block outs shall conform to electrical drawing Dwg. No. SE-GIS-0-01-01/01 and Dwg. No. KK1-S-6. Other facilities layouts shall conform to requirements with reference to architectural drawings

54.1.8 Size of 115 kV GIS and Control building can be selected for the design and shall be submitted with the proposal in the bidding process.

54.1.9 The design of building shall analyze and take the following aspects into consideration: Site, Environment, Context, Function, Climate (sunlight, wind, rain, heat etc.), Energy efficiency, Safety and including aesthetic of architecture to encourage EGAT corporate identity.

54.1.10 Building facilities

- Electricity and illumination system including cable work for illumination, ventilation system, power supply, air conditioning system, and telephone system.
- Plumbing system for water supply, building drain and vent, storm water drainage including sanitary wares and fittings.
- Miscellaneous including grounding and labeling.
- Cable routing and cable support (cable tray and cable ladder) installed in cable room and main cable trench.
- Overhead traveling crane, of lifting capacity not less than 5 metric tons and wireless crane remote control. Overhead traveling crane shall have cat-walk for maintenance the equipment on ceiling.
- Hoist crane, for loading area, of lifting capacity not less than 2 metric tons and wireless crane remote control.
- Access floor system or Raised flooring system (For walking area)
 - Panels shall be capable of supporting a uniform load or distributed load not less than 1,500 kg/sq.m.
 - Floor panels shall consist of calcium sulphate have protection against humidity, rotting and fire. Panels shall be jig-milled to thickness size.
 - *Thickness : not less than 35 mm.
 - *Module : 600x600 mm. or 24x24 Inches
 - Finish the surface of the floor panels with floor covering material indicated mineral panels with High Pressure Laminated (HPL) shall be not less than 1.5 mm. from manufacturer standard.
 - Panels material shall be non-combustible, fire retardant, or the fire resistant building material class A, with galvanized steel plate covering both on the top and bottom of the panel.

- The understructure system of access floor such as pedestal profile, Stringer, head plate and steel bolt shall be made of Electroplated Galvanized Steel (ASTM A879)
- The system frame area which are fixed to the current system by bolting and adhesive shall be unwelded connection.
- The access floor system, following standard :
 - *Load test : EN 12825 or CISCA
 - *Fire test : DIN4102 : F30 A or ASTM E84 Class A or BS476 part 4 Class A
- The test report shall be certified by a third party accredited laboratory.
- The pattern of access floor (Walking area) relating to cable route and equipment layout shall be submitted to EGAT for approval.
- All components of access floor system, which consist of floor panel, stringer, pedestal, and other part, shall be manufactured by the same manufacturer.
- With 10 years guarantee of material and 2 years installation.
- The access floor system material in the Specification No.3001 (Civil and Architectural work) No.3001-10.8.3.5 Access Floor System (Raised Flooring System) shall be cancelled.
- Signboard on building and room name sign on each room.
- Warning sign provided in accordance with EIT Standard or Quality and Safety Development Division Standard (EGAT).
- The furniture list shall be added as the follow detail.
 - Complete set of pantry storage side board that consists base cabinet and wall hanging cabinet, including one stainless tap and full set of pantry accessories.

Other furniture items from the reference drawing not included in this contract.

55. Construction of

55.1 22/33 kV Switchgear Building.

- Fire protection for steel structure shall conform to legal provision, EGAT's specifications and Design manual for substation. Therefore, Fire protection specification in Architecture drawing shall be cancelled
- The high flexible cementitious waterproofing coating material shall be applied to the working rooms to prevent moisture from the ground. Therefore, the floor remark section in the referenced drawings concerning installation areas of the said material shall be cancelled.

Water Supply System

56. Design and construction of

56.1 Water Supply System

Civil Work

57. Design and construction of

57.1 Steel structure and foundations for Specified equipment and the others not shown in "For Construction drawings" and / or EGAT's specification.

57.1.1 Transformer foundation with oil containing pit.

57.1.2 115 kV GIB & GIS bushing structure and foundation.

57.1.3 Take-off structure foundations.

57.1.4 115 kV Terminator support foundation.

57.1.5 Cable tray for transformer, underground cable in HDPE duct.

57.1.6 Deadend structure foundation to PEA.

57.1.7 22&33kV Distribution transformer foundation.

57.1.8 Outdoor marshalling cubicle foundation.

57.1.9 Outdoor main distribution board foundation.

57.1.10 Neutral reactor support structure foundation.

57.1.11 Outdoor load break switch foundation.

57.1.12 Lighting relay panel support foundation.

57.2 Road and drainage system.

57.3 Drainage system for cable trench.

57.4 Oil containing pit with steel grating and black steel spiral-seam pipes (TIS 427-2531) with protection method according to AWWA C217, C205. (Design sizing for oil drain system only)

- 57.5 Three minutes 3D animation presentation file (MP4, resolution not less than 1440 p; 2500 x 1440) demonstrating details of switchyard and interior and exterior buildings shall be arranged.
- 57.6 Cable trench type A and B with RC cover for 22 kV XLPE system.
- 57.7 Cable trench type A and B with RC cover for 115 kV XLPE system.
- 57.8 Switch yard entrance gate (sliding or swing door)
- 58. Construction of
 - 58.1 Steel structure foundation.
 - 58.2 Take-off foundation.
 - 58.3 Equipment structure foundation with sub trench (if required).
 - 58.4 Dead man hook for loading transformer
 - 58.5 Transformer loading.
 - 58.6 Cable trench.
 - 58.7 RC. Road.
 - 58.8 Oil separator.
 - 58.9 Oil containing pit with steel grating and black steel spiral-seam pipes (TIS 427-2531) with protection method according to AWWA C217, C205.
 - 58.10 Crushed rock surfacing.
 - 58.11 Wire mesh fence.
 - 58.12 Site office.
 - 58.13 Guard house.
 - 58.14 Lamp post for fence and access road lighting LED type foundation.
 - 58.15 Switchyard entrance gate.
- 59. The drawings and calculation of all buildings shall be verified with adequate details for intended application and submitted to EGAT for approval.
- 60. All design works and the fabrication drawings for all steel structures shall be submitted to EGAT for approval.
- 61. All design, construction and testing shall be in accordance with Specification No.3001 : Civil and Architectural Work.
- 62. EGAT's Soil Investigation Report (attached to the Contract) is a document that can be a reference for design, however; the review of the soil investigation report shall be under responsibility of the Contractor and the warranty of work shall remain following all obligations as specified in the Contract.

63. All foundations shall be as specified in layout drawing. Except the result of soil investigation shows that the specified foundations are not appropriate, the Contractor shall design the proposed foundations.
64. The Contract price shall be adjusted (added or reduced) in case that the soil investigation results to be used for the design works is different from the layout and standard drawings.
65. The Contractor shall perform a static load test for 115 kV GIS and Control/Relay Building foundations in accordance with ASTM D1143 (if pile type foundation is required).
66. Seismic load test (sonic integrity test) according to ASTM D5882-96 shall be applied to all bored piles (if bored pile type is required).
67. Plate bearing test according to ASTM D1194-94 shall be submitted to EGAT for approval. (If pad type foundation is required).
68. The Contractor shall remove all debris from construction material and other works in order to make the site clean and be in the condition acceptable to EGAT.
69. According to the Contract Document Section G-3 : Contractor's Office and Other Construction Facilities; the detail in paragraph 3 shall be changed as follows : the Contractor shall provide for EGAT an office container at the site during construction with a minimum space of 36 sq.m for office area, 24 sq.m for conference room which shall both be air-conditioned and 4 sq.m for toilet. The facilities as shown on the section G-3 are required for 2 sets.
70. Site preparation
 - 70.1 The preparation of the area to be covered by crushed rock surfacing and GIS building area shall be done by contractor in such a way as stripping top soil and remove all objectionable materials then back fill with compacted soil.
 - 70.2 Existing to be remove
 - 70.2.1 Ground floor structure and foundation of existing switchgear building.
 - 70.2.2 Steel structure foundation.
 - 70.2.3 Take-off foundation.
 - 70.2.4 Equipment structure foundation.
 - 70.2.5 Cable trench.
 - 70.2.6 RC road.
 - 70.2.7 Wire mesh fence.

- 70.2.8 Switchyard entrance gate.
- 70.2.9 Gutter.
- 70.2.10 Drainage sump and pipe.
- 70.2.11 Foot path.
- 70.2.12 Garden tree.
- 70.2.13 Steel support and RC. Slab for 22kV power cable.
- 70.2.14 Underground water tank.
- 70.2.15 Guard house.

Work not included in this Contract. The Work not included in this Contract shall be as shown on the drawings and as follows:

1. Supply and installation of 115/22-11 kV power transformers “KT1A, KT2A & KT6A”.
2. The stringing work for the connection between the 230 kV & 115 kV substation take-off structures and the dead-end towers of the transmission lines.
3. Supply suspension and station post insulators.
4. Supply of Remote Terminal Units (RTUs), Master Station Unit and application software.

2. KHON KAEN 2 SUBSTATION (KK2) (JOB NO. RTS2-03-S35)

Schedule 2

Work included in this Contract. The Work included in this Contract to be performed by the Contractor shall be as specified in the Contract Documents and as follows:

Control and Protection System

1. Design, supply, installation, wiring, test and commissioning of the complete control and protection system which comprises of at least the following equipment:
 - Duplex type protective relay switchboards
 - Interposing relay panels
 - Loose equipment as specified in the price schedules.
 - Cable and accessories as well as connection of cables among all the he existing panels and the associated equipment in order to complete the function of the control and protection system.
2. Design, modification, wiring, test and commissioning of the existing equipment which comprises at least the following equipment in order to incorporate the new equipment:
 - The existing panels such as 400/230 VAC board, 125 VDC board, existing control and protection panels, marshalling panels (e.g. for the remote terminal unit, the fault recording system, teleprotection, control system, transformer, etc.) and fault recording system.
3. Design, of the schematic and wiring diagrams of the additional inputs to the existing Computerized Control System (CCS). The test and commissioning of the completed CCS shall be performed by the Contractor.
4. The existing drawings shall be modified by the Contractor and submitted to EGAT for approval. The final drawings shall be submitted as ACAD files.
5. The Contractor shall be responsible for providing complete schematic and wiring diagrams of the control and protection system.
6. Removal of the unused existing cables. The removed cables shall be neatly reeled and kept in a suitable place recommended by EGAT.

3. KHON KAEN 1 SUBSTATION (KK1) (FIRE PROTECTION SYSTEM PHASE 3)
(JOB NO. FPS2-01-S17)

Schedule 3

Work included in this Contract. The Work included in this Contract to be performed by the Contractor shall be as specified in the Contract Documents and as follows:

FIRE PROTECTION SYSTEM

1. Design and construction of

1.1 Fire protection system for 115 kV GIS and Control Building.

1.1.1 Control area shall consist of Total Flood Clean Agent Fire Suppression System with heat detector, addressable type smoke detector and aspirated smoke detector.

1.1.2 GIS area shall consist of video image smoke detector system, optical beam smoke detector and aspirated smoke detector.

1.1.3 Fire protection system of 115 kV GIS and Control Building shall have trouble and operation visual and audible signals (environmental monitoring), which indicate change of state of any connected device, shown and recorded at control room in 115 kV GIS and Control Building. The installation practice shall be in accordance with the last edition of NFPA 72.

1.1.4 There shall be sounder and beacon on the roof of the building.

1.1.5 For system requirements for indoor fire protection system as shown on specification 3001-10.13.1 part e, item no.1 and 6 shall be changed to the new details as follow

(1) System description and operation : Supply and Installation of a Total Flood Clean Agent Fire Suppression System utilizing IG-100 shall cover all these zones :

Zone 1: Equipment (Control/Relay) Room ;

Zone 2: Electrical Room ;

Zone 3: Under Raised Floor ;

Zone 4: Battery Room ;

Zone 5: Cable Room ;

Zone 6: Inert Gas Room

Other zone (If required)

Each protected zone shall have its own set of IG-100 cylinders.

- (6) Detectors shall be cross-zoned detection requiring 2 detectors to be in alarm before discharge. A zone of A or B of addressable smoke detector and a zone C of all ASD shall be crossed.

1.1.6 For air sampling smoke detector as shown on specification 3001- 10.13.2 part i item no.1, 7, 13 and 14 shall be changed to the new details as followings :

i. Air Sampling Smoke Detector.

- (1) Shall consist of a high sensitivity type detector, using light scatter technology.
- (7) Detection system must be included in all control cabinet and can locate a scene.
- (13) The minimum sensitivity settings for a single sampling hole are so that the detection system alarm at 1.5% obs/ft (4.95% obs/m). A sampling hole maximum coverage area is 400.0 sq.ft (37.2 sq.m).
- (14) Maximum transport time from the most remote port to the detection unit of an air-sampling system shall be a maximum of 90 seconds.

1.1.7 Fire protection system, fire alarm system, installation room and accessories shall be in accordance with the applicable requirements set forth in the latest edition of the following codes and standards:

- NFPA 2001: Clean Agent Fire Extinguishing Systems
- NFPA 70: National Electrical Code.
- NFPA 72: National Fire Alarm Code.
- NFPA 75: Standard for the Fire Protection of Information Technology Equipment.
- NFPA 76: Standard for the Fire Protection of Telecommunications Facilities.
- EGAT's Standard Design Manual of Fire Protection and Suppression for Substation. (คู่มือมาตรฐานการออกแบบเพื่อป้องกันและระงับอัคคีภัยสถานีไฟฟ้าแรงสูงการไฟฟ้าฝ่ายผลิตแห่งประเทศไทย)
- IEEE Std 979: IEEE Guide for Substation Fire Protection

- NFPA 850: Recommended Practice for Fire Protection for Electric Generating Plants and High Voltage Direct Current Converter Substations.

1.1.8 There shall be one control panel for fire detection system and IG-100 fire suppression system for each room which is protected by the IG-100 fire suppression system.

1.1.9 There shall be a protective clear polycarbonate cover which can be immediately lifted or opened for all IG-100 manual release stations.

1.2 Fire protection system for 22/33 kV Switchgear Building.

1.2.1 Switchgear Building shall consist of Total Flood Clean Agent Fire Suppression System with addressable type smoke detector and aspirated smoke detector.

1.2.2 Fire protection system of Switchgear Building shall have trouble and operation visual and audible signals (environmental monitoring), which indicate change of state of any connected device, shown and recorded at control room in 115 kV GIS and Control Building. The installation practice shall be in accordance with the last edition of NFPA 72.

1.2.3 There shall be sounder and beacon on the roof of the building.

1.2.4 For system requirements for indoor fire protection system as shown on specification 3001-10.13.1 part e, item 6 shall be changed to the new details as follow

- (6) Detectors shall be cross - zoned detection requiring 2 detectors to be in alarm before discharge. A zone of A or B of addressable smoke detector and a zone C of all ASD shall be crossed.

1.2.5 For air sampling smoke detector as shown on specification 3001- 10.13.2 part i item no.1, 7, 13 and 14 shall be changed to the new details as followings :

i. Air Sampling Smoke Detector.

- (1) Shall consist of a high sensitivity type detector, using light scatter technology.
- (7) Detection system must be included in all control cabinet and can locate a scene.
- (13) The minimum sensitivity settings for a single sampling hole are so that the detection system alarm at 1.5% obs/ft (4.95% obs/m). A sampling hole maximum coverage area is 400.0 sq.ft (37.2 sq.m).

(14) Maximum transport time from the most remote port to the detection unit of an air-sampling system shall be a maximum of 90 seconds.

1.2.6 Fire protection system, fire alarm system, installation room and accessories shall be in accordance with the applicable requirements set forth in the latest edition of the following codes and standards:

- NFPA 2001: Clean Agent Fire Extinguishing Systems
- NFPA 70: National Electrical Code.
- NFPA 72: National Fire Alarm Code.
- NFPA 75: Standard for the Fire Protection of Information Technology Equipment.
- NFPA 76: Standard for the Fire Protection of Telecommunications Facilities.
- EGAT's Standard Design Manual of Fire Protection and Suppression for Substation.(คู่มือมาตรฐานการออกแบบเพื่อป้องกันและระงับอัคคีภัยสถานีไฟฟ้าแรงสูงการไฟฟ้าฝ่ายผลิตแห่งประเทศไทย)
- IEEE Std 979: IEEE Guide for Substation Fire Protection
- NFPA 850: Recommended Practice for Fire Protection for Electric Generating Plants and High Voltage Direct Current Converter Substations

1.2.7 There shall be a protective clear polycarbonate cover which can be immediately lifted or opened for all IG-100 manual release stations.

- 1.3 Fire protection system for the switchyard to meet the requirement as specified in IEEE Guide for Substation Fire Protection: IEEE Std 979, all requirements of NFPA 850 and EGAT's Standard Design Manual of Fire Protection and Suppression for Substation (คู่มือมาตรฐานการออกแบบเพื่อป้องกันและระงับอัคคีภัยสถานีไฟฟ้าแรงสูงการไฟฟ้าฝ่ายผลิตแห่งประเทศไทย).
- 1.4 ASD system for cabinets shall be able to alarm and address the source of smoke within 60 seconds and no later than transport time of ASD of each cabinet
- 1.5 Fire Pump System. (Conforming to NFPA 14, 20, 22, 24, 72).
- 1.6 250 cu.m water storage tank, fire pump, and jockey pump shall have trouble and operation visual and audible signals (environmental monitoring), which indicate change of state of any connected devices, shown and recorded at control room in

115 kV GIS and Control Building. The installation practice shall be in accordance with the latest edition of NFPA 72.

- 1.7 There shall be one fire alarm system graphic annunciator at each building to enable responding personnel to identify the location of a fire accurately and to indicate the status of emergency equipment or fire safety functions.
- 1.8 There shall be one graphic annunciator which displays alarm, discharge and trouble signals of fire alarm system of other buildings, (fire pump houses, transformers, shunt reactors) at the building where control room locates.
- 1.9 Fire protection system circuits for buildings and switchyards: notification appliance circuits, and signaling line circuits, shall be class A circuit. Initiating device circuits can be class B circuit.
- 1.10 Signals of indoor fire protection system of each room and signals of outdoor fire protection system shall be sent to local CCS, GCC, RCC, and NCC as following details;

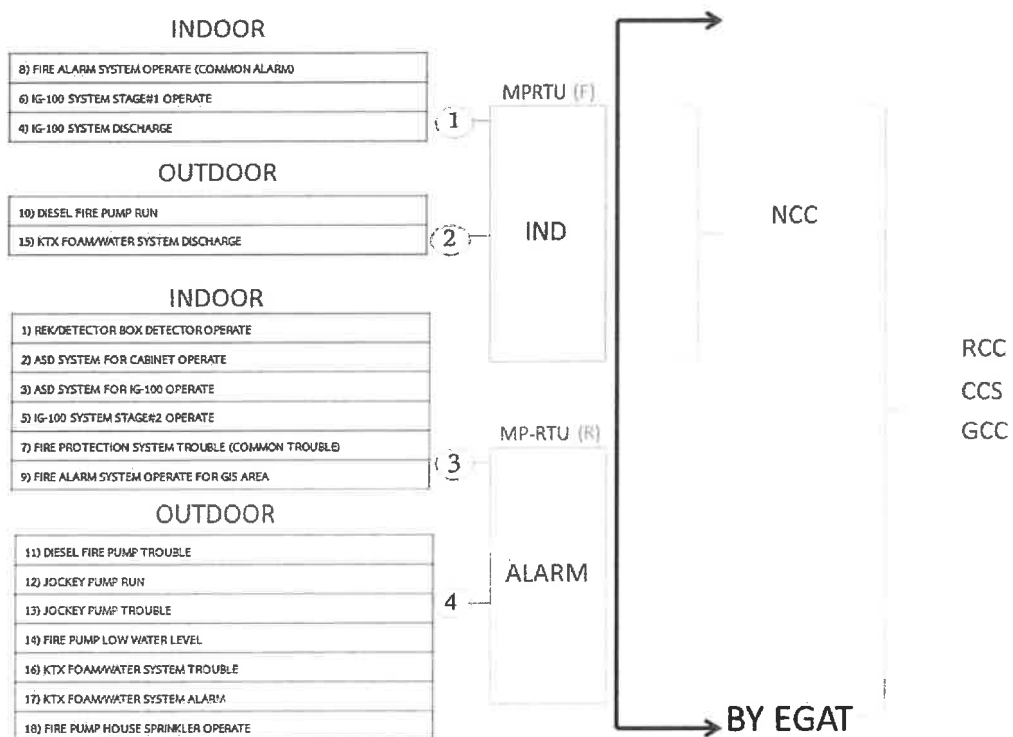

- 1.11 There shall be only one subcontractor engaging in design, supply and installation of Fire Protection System for Buildings and Switchyard.
- 1.12 All building wall openings for fire protection dampers shall be provided with stainless steel louvers and insect screens to install inside of building.

1.13 For portable fire extinguisher as shown on specification 3001- 10.13.3 shall be changed to the new details as followings :

- The fire extinguishers shall be conformed to latest TIS standards. The portable and mobile fire extinguishers shall be carbon dioxide (CO₂) conforming to TIS 881 and/or dry chemical conforming to TIS 332 , capacity 10 lbs/set. The fitting accessories shall be provided.
- The portable fire extinguishers shall be installed according to the latest NFPA 10 and the latest EGAT's Standard of Fire Suppression for Substation. (ระเบียบการไฟฟ้าฝ่ายผลิตแห่งประเทศไทย ฉบับที่ 107 ว่าด้วย “มาตรฐานระบบดับเพลิงสถานีไฟฟ้าแรงสูง”).

1.14 For safety sign of fire protection system shall be conformed to EGAT's Safety Sign Standard. (ระเบียบการไฟฟ้าฝ่ายผลิตแห่งประเทศไทย ฉบับที่ 100 ว่าด้วย “มาตรฐานเครื่องหมายความปลอดภัย”)

1.15 Fire protection system work shall be inspected and maintained for 2 years, not less than 4 times per year and not less than manufacturers' recommendation.

1.16 There shall be a set of computer desk with chair, a set of CPU which suitable for fire protection system software and operate 24 hours a day and a set of 24” LED monitor which show the status of fire protection system in control room in 115 kV GIS and Control Building. If there is any video image smoke detector in GIS area, there shall be one more monitor which shows the detecting zone of each video image smoke detector. One set of laser jet printer shall be provided.

2. Construction of

2.1 Fire pump house.

2.2 Cabinets with 2x50 lbs wheel fire extinguisher.

2.3 Water storage tank for fire protection system (capacity not less than 250 cu.m).