

ข้อมูลประชาสัมพันธ์และช่องทางรับข้อคิดเห็นหรือข้อร้องเรียน
ด้านการส่งเสริมคุณธรรมและความโปร่งใสในการดำเนินการ



นโยบายต่อต้านการให้หรือรับสินบนเพื่อป้องกันการทุจริต
และประพฤติมิชอบ



จรรยาบรรณของผู้ปฏิบัติงานจัดซื้อจัดจ้างและบริหารพัสดุ



ช่องทางรับข้อคิดเห็นหรือข้อร้องเรียน *

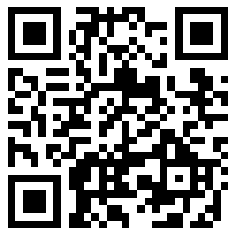

การแจ้งข้อคิดเห็นหรือข้อร้องเรียนทางเว็บไซต์ กฟผ. *



จรรยาบรรณคู่ค้า กฟผ. **

* ไม่ใช่ช่องทางแสดงความคิดเห็นร่างขอบเขตของงานหรือรายละเอียดคุณลักษณะเฉพาะของพัสดุที่จะซื้อหรือจ้าง/ ร่างประกาศ/ ร่างเอกสารประกวดราคาฯ

** กฟผ. จัดทำและเผยแพร่จรรยาบรรณคู่ค้า เพื่อให้คู่ค้าของ กฟผ. ทุกรายมีแนวปฏิบัติในการดำเนินธุรกิจอย่างมีจริยธรรมและธรรมาภิบาล โดยคำนึงถึงสิ่งแวดล้อม สังคม การกำกับดูแลกิจการที่ดี ปฏิบัติตามกฎหมาย และเคารพหลักสิทธิมนุษยชน ดังมีรายละเอียดระบุใน QR Code จรรยาบรรณคู่ค้า กฟผ."

EGAT's Privacy Notice on Procurement, Inventory Management and Contract Administration

Electricity Generating Authority of Thailand (EGAT) has performed the protection of the Personal Data regarding procurement, inventory management and contract administration to be in accordance with the **Personal Data Protection Act B.E. 2562** (the "2019 PDPA"), which comes into effect on June 1, 2022.

Details about EGAT's Privacy Notice on Procurement, Inventory Management and Contract Administration are available for you at https://www.egat.co.th/privacy-notice-procurement_en.html or the below QR Code.



The Redaction of Sensitive Personal Data

EGAT has announced the Privacy Notice on Procurement, Inventory Management and Contract Administration for the collection, use or disclosure of Personal Data, excluding the Sensitive Personal Data.

Should the documents you wish to submit to EGAT contain the Sensitive Personal Data as defined in Section 26 of the 2019 PDPA, pertaining to racial, ethnic origin, political opinions, cult, religious or philosophical beliefs, sexual behavior, criminal records, health data, disability, trade union information, genetic data, biometric data, or of any data which may affect you in the same manner, you shall redact or conceal such data before submitting to EGAT.

ประกาศความเป็นส่วนตัว (Privacy Notice) สำหรับการจัดซื้อจัดจ้าง การบริหารพัสดุ และการบริหารสัญญาของ กฟผ.

การไฟฟ้าฝ่ายผลิตแห่งประเทศไทย (กฟผ.) ได้ดำเนินการคุ้มครองข้อมูลส่วนบุคคลสำหรับการจัดซื้อจัดจ้าง การบริหารพัสดุ และการบริหารสัญญา เพื่อให้เป็นไปตามพระราชบัญญัติคุ้มครองข้อมูลส่วนบุคคลของประเทศไทย พ.ศ. 2562 (PDPA) ซึ่งมีผลบังคับใช้อย่างครบถ้วน ตั้งแต่วันที่ 1 มิถุนายน 2565 ทั้งนี้ ท่านสามารถศึกษารายละเอียดประกาศความเป็นส่วนตัว (Privacy Notice) สำหรับการจัดซื้อจัดจ้าง การบริหารพัสดุ และการบริหารสัญญา ได้ที่ <https://www.egat.co.th/privacy-notice-procurement.html> หรือที่ QR Code ด้านล่าง



การขิดฆ่าข้อมูลส่วนบุคคลอ่อนไหว

กฟผ. มีประกาศความเป็นส่วนตัว (Privacy Notice) สำหรับการจัดซื้อจัดจ้าง การบริหารพัสดุ และการบริหารสัญญา เพื่อใช้ในการเก็บรวบรวม ใช้ หรือเปิดเผย ข้อมูลส่วนบุคคล แต่ไม่เก็บข้อมูลส่วนบุคคลอ่อนไหว หากเอกสารของท่านที่ต้องส่งมอบให้ กฟผ. มีข้อมูลส่วนบุคคลอ่อนไหวตามที่ถูกบัญญัติไว้ในมาตรา 26 ของ PDPA ดังนี้ เชื้อชาติ เผ่าพันธุ์ ความคิดเห็นทางการเมือง ความเชื่อในลัทธิ ศาสนาหรือปรัชญา พฤติกรรมทางเพศ ประวัติอาชญากรรม ข้อมูลสุขภาพ ความพิการ ข้อมูลสหภาพแรงงาน ข้อมูลพันธุกรรม ข้อมูลชีวภาพ หรือข้อมูลอื่นใด ซึ่งกระทบต่อเจ้าของข้อมูลส่วนบุคคลในทำนองเดียวกันรวมอยู่ด้วย ขอให้ท่านขิดฆ่า หรือปกปิดข้อมูลดังกล่าว ก่อนส่งมอบให้แก่ กฟผ.

**1st Draft of Terms of Reference,
Announcement and Details of Medium Cost
for Invitation to Bid No. SPSR-RX-01
Supply of 500 kV 110 MVAR Shunt Reactor
Supply and Installation of 500 kV 110 MVAR Shunt Reactor**

The Electricity Generating Authority of Thailand (EGAT) plans to call for proposals for the subject Invitation to Bid. Any person who has the authorization from the company, firm, joint venture or consortium who supplies or manufactures the equipment required under the subject invitation to Bid is allowed to submit a comment against the first draft of the Terms of Reference (TOR), the Announcement and the Details of Medium Cost attached herewith.

How to Comment

Those who would like to comment shall submit an official letter signed by the authorized person(s) together with the letter of authorization or the power of attorney, and addressed to “Chief, Procurement Department - Transmission System Segment, Central Procurement and Inventory Management Division”.

Comments shall be submitted via email address: chulalak.sap@egat.co.th with all related documents attached (e.g. the letter of authorization and the power of attorney).

Comments shall be received by EGAT on or before ***June 5, 2026***, Bangkok Standard Time, **otherwise the comments will not be taken into consideration.**

EGAT reserves the right to change or not to change the terms and conditions contained in the Terms of Reference, the Announcement and the Details of Medium Cost subject to its consideration and such decision shall be final.



Miss Benyalak Saralamba

Head, Procurement Section - Transmission System Segment 3

May 27, 2026

Notice to Bidder

Subject : Online Payment for Purchase of Bidding Documents

Please be informed of the online payment for purchase of bidding documents as follows:

- 1) Fill-out the Registration Form and the proof of payment in the link provided in <https://www4.egat.co.th/fprocurement/biddingeng>

Payment shall be made by bank transfer or telegraphic transfer to EGAT's account no. 109-6-01958-2 (swift code : KRTHTHBK), Krung Thai Bank Public Company Limited, Bangkruai Branch, Nonthaburi.

All bank charges and fees incurred by the payment of bidding documents shall be under the buyer's responsibility.

- 2) The registration will be deemed complete only upon successful processing of the payment and confirmation of funds received.
- 3) After the payment has been verified for approximately 3 working days, the in-charge officer will send the link for downloading the bidding documents together with the receipt to the purchaser's email address in the Registration Form.



Invitation to Bid No. SPSR-RX-01
Supply of 500 kV 110 MVAR Shunt Reactor
Supply and Installation of 500 kV 110 MVAR Shunt Reactor

The Electricity Generating Authority of Thailand (EGAT) is calling for the subject Invitation to Bid to be financed by EGAT's fund. The project is on the process of the Government's Approval. The Bid may be cancelled in case the project is not approved.

Place of Delivery : Laem Chabang Port / Ex-works

Medium Cost (including Value Added Tax and other expenses) : THB 75,400,000.-

Eligibility of Bidders

1. The Bidder shall be a juristic person who manufactures or provides such materials or services and shall not be named in the List of Work Abandoners published by the Permanent Secretary, Ministry of Finance, and/or in the Debarment List and/or in the List of Work Abandoners declared by EGAT.
2. The Bidder shall not be a Jointly Interested Bidder with other Bidders as from the date of EGAT's issuance of the Invitation, or shall not be a person who undertakes any action as an "Obstruction of Fair Price Competition" for this Invitation.
3. The Bidder shall not either be EGAT's consultant or involve in EGAT's consultancy company under this Invitation to Bid, or shall not have EGAT's personnel involved in his business as shareholder having voting right that can control his business, director, manager, officer, employee, agent, or consultant except those who are officially ordered by EGAT to act or participate therein.
4. The Bidder shall not be the person who is privileged or protected not to be taken any legal proceedings under Thai Court; Provided that such Bidder's government declares that such special privilege is waived.
5. The Bidder who is a joint venture or consortium shall carry out all the work under such formation from the time of bidding until the fulfillment of the Contract.

Availability of Bidding Documents

Bidding Documents are available for online purchase during 8:00 hrs. to 15:00 hrs., Bangkok Standard Time, as from _____ to _____ at USD 70.- or THB 2,000.- per copy, non-refundable.

Please find more details for online purchasing process at <https://www.egat.co.th/fprocurement/biddingeng> or contact for further information at telephone no. 66 2436 0346 or procurement.tse@egat.co.th.

Delivery of Bids

Bids shall be submitted at Bidding Room, 1st Floor, Tor 137 Building at EGAT's Head Office, Nonthaburi during 9:00 hrs. to 10:00 hrs., Bangkok Standard Time, _____ and will be opened publicly at 10:00 hrs.

ELECTRICITY GENERATING AUTHORITY OF THAILAND

(Date of Announcement)

(Miss Wallapa Chewadhnakorkul)

Chief, Procurement Department – Transmission System Segment



ประกาศการไฟฟ้าฝ่ายผลิตแห่งประเทศไทย
เรื่อง ประกวดราคาซื้อ เลขที่ SPSR-RX-01

การไฟฟ้าฝ่ายผลิตแห่งประเทศไทย (กฟผ.) มีความประสงค์จะซื้อ 500 kV 110 MVAR Shunt Reactor สำหรับงานจัดหาวัดติดตั้ง 500 kV 110 MVar Shunt Reactor โดยใช้งบประมาณ กฟผ. ทั้งนี้ โครงการอยู่ระหว่างการขออนุมัติจากคณะกรรมการการจัดทากรครั้งนี้จะไม่ผูกพัน กฟผ. หากโครงการไม่ได้รับอนุมัติ

สถานที่ส่งมอบ : ท่าเรือแหลมฉบัง / หน้าโรงงานผู้ผลิต

ราคากลาง (รวมภาษีมูลค่าเพิ่มและค่าใช้จ่ายอื่นๆ) : 75,400,000.- บาท

คุณสมบัติของผู้เสนอราคา

1. ต้องเป็นนิติบุคคลผู้ผลิตหรือเป็นผู้มีอาชีพขายพัสดุดตามประกาศ และต้องไม่เป็นผู้ที่งานซึ่งปลัดกระทรวงการคลังได้แจ้งเวียนชื่อไว้หรือต้องไม่เป็นผู้ที่ กฟผ. ห้ามติดต่อหรือห้ามเข้าเสนอราคา หรือต้องไม่เป็นผู้ที่ได้รับผลของการสั่งให้นิติบุคคลหรือบุคคลอื่นเป็นผู้ทำงานตามคำสั่ง กฟผ.
2. ต้องไม่เป็นผู้มีผลประโยชน์ร่วมกันกับผู้เสนอราคารายอื่น ณ วันประกาศประกวดราคาครั้งนี้เป็นต้นไป หรือต้องไม่เป็นผู้กระทำการอันเป็นการขัดขวางการแข่งขันราคาอย่างเป็นธรรมในการดำเนินการประกวดราคาครั้งนี้
3. ต้องไม่เป็นที่ปรึกษาของ กฟผ. หรือมีส่วนร่วมในบริษัทที่ปรึกษาของ กฟผ. ในงานนี้ หรือต้องไม่มีผู้ปฏิบัติงาน กฟผ. เข้าไปมีส่วนร่วมในกิจการของผู้เสนอราคา ไม่ว่าจะในฐานะผู้ถือหุ้นที่มีสิทธิควบคุมการจัดการ กรรมการ ผู้อำนวยการ ผู้จัดการ พนักงาน ลูกจ้าง ตัวแทนหรือที่ปรึกษา ยกเว้น ในกรณีที่ผู้ปฏิบัติงานได้รับคำสั่งอย่างเป็นทางการจาก กฟผ. ให้ไปปฏิบัติงานหรือเข้าร่วมในกิจการของผู้เสนอราคา
4. ต้องไม่เป็นผู้ได้รับเอกลิทธิหรือความคุ้มครอง ซึ่งอาจปฏิเสธไม่ยอมขึ้นศาลไทย เว้นแต่รัฐบาลของผู้เสนอราคาได้มีคำสั่งให้สละสิทธิและความคุ้มครองเช่นนั้น
5. ผู้ประสงค์เข้าประกวดราคาในนามของกิจการร่วมค้าหรือกิจการค้าร่วม (Joint Venture or Consortium) จะต้องดำเนินการทุกขั้นตอนของการประกวดราคาในนามของกิจการร่วมค้าหรือกิจการค้าร่วม ตั้งแต่การเสนอราคาจนสิ้นสุดข้อผูกพันกับ กฟผ.

การขายเอกสารประกวดราคา

ผู้สนใจติดต่อซื้อเอกสารประกวดราคา ในราคาชุดละ 2,000.- บาท ในวันทำการระหว่างเวลา 08:00 น. ถึง 15:00 น. ตั้งแต่วันที่ _____ ถึงวันที่ _____ ทั้งนี้ สามารถดูรายละเอียดการซื้อเอกสารประกวดราคาได้ที่เว็บไซต์ <https://www4.egat.co.th/fprocurement/biddingeng> หรือสอบถามข้อมูลเพิ่มเติมได้ทางโทรศัพท์ หมายเลข 0 2436 0346 หรืออีเมล procurement.tse@egat.co.th

การยื่นซองประกวดราคา

กำหนดยื่นซองประกวดราคา ในวันที่ _____ เวลา 09:00 น. ถึง 10:00 น. และเปิดซองประกวดราคา เวลา 10:00 น. ณ ห้องประกวดราคา ชั้น 1 อาคาร ท.137 การไฟฟ้าฝ่ายผลิตแห่งประเทศไทย เชียงสะพานพระราม 7 จังหวัดนนทบุรี

ประกาศ ณ วันที่ _____

(นางสาววัลลภา ชีวธนากรณ์กุล)

หัวหน้ากองจัดซื้อจัดจ้างสายงานระบบส่ง

ตารางแสดงวงเงินงบประมาณที่ได้รับจัดสรรและราคากลาง(ราคาอ้างอิง)
ในการจัดซื้อจัดจ้างที่มีใช้งานก่อสร้าง

1. ชื่อโครงการ Bid No. SPSR-RX-01

การจัดซื้อ 500 kV 110 MVAR Shunt Reactor

งานจัดหาพร้อมติดตั้ง 500 kV 110 MVar Shunt Reactor

/หน่วยงานเจ้าของโครงการ ฝ่ายแผนงานและโครงการระบบส่ง การไฟฟ้าฝ่ายผลิตแห่งประเทศไทย

2. วงเงินงบประมาณที่ได้รับจัดสรร

งานจัดหาพร้อมติดตั้ง 500 kV 110 MVar Shunt Reactor

งบประมาณ 77.40 ล้านบาท

3. วันที่กำหนดราคากลาง 9 เมษายน 2569 (วันที่ อวส. อนุมัติ)

ราคารวมภาษีมูลค่าเพิ่มและค่าใช้จ่ายอื่นๆ เป็นเงิน 75,400,000.00 บาท ราคา/หน่วย ตามเอกสารแนบ

4. แหล่งที่มาของราคากลาง

หลักเกณฑ์การกำหนดราคากลางการจัดซื้อและจัดจ้างงานก่อสร้างระบบส่งไฟฟ้าของสายงานพัฒนาระบบส่ง

5. รายชื่อเจ้าหน้าที่ผู้กำหนดราคากลาง

5.1 นายณัฐวุฒิ วงศ์เทพวณิชย์ หมพ-ร. กวอ-ร.

5.2 นางสาวณัฐณิชา เพชรรักษ์ วศ.4 หมพ-ร. กวอ-ร.

หมายเหตุ ค่าใช้จ่ายอื่นๆ ได้แก่ ค่าใช้จ่ายที่ กฟผ. ต้องจ่ายตามวิธีการพิจารณาเปรียบเทียบราคาที่กำหนดไว้

ในเอกสารประกวดราคา เช่น อากรขาเข้า เป็นต้น

MEDIUM COST FOR BID NO. SPSR-RX-01
SUMMARY OF BID PRICE
SUPPLY OF 500 KV 110 MVAR SHUNT REACTOR
SUPPLY AND INSTALLATION OF 500 KV 110 MVAR SHUNT REACTOR

No.	Description	Currency	Supply of Equipment	Supply of Equipment	Foreign Currency (excluding VAT)	Local Currency (excluding VAT) Baht
			Foreign Supply	Local Supply		
			CFR Thai Port	Ex-works Price (excluding VAT) Baht		
			Amount	Amount		
1	Schedule 1 : 500 kV Shunt Reactor	THB	69,500,000.00		556,000.00	
BID PRICE		THB	69,500,000.00	Baht	556,000.00	Baht
IMPORT DUTY		THB		Baht		Baht
CUSTOM CLEARANCE		THB	417,000.00	Baht		Baht
VAT		THB	4,865,000.00	Baht	38,920.00	Baht
SUMMARY OF BID PRICE		THB	74,782,000.00	Baht	594,920.00	Baht
TOTAL MEDIUM COST		THB	75,376,920.00			
TOTAL MEDIUM COST (ROUND)		THB	75,400,000.00			

 นายสมชัย เจริญศรีเกษม
 ผู้อำนวยการฝ่ายวิศวกรรมระบบส่ง
 9 Apr 2026

MEDIUM COST FOR BID NO. SPSR-RX-01
Schedule 1 : 500 kV Shunt Reactor
SUPPLY OF 500 KV 110 MVAR SHUNT REACTOR
SUPPLY AND INSTALLATION OF 500 KV 110 MVAR SHUNT REACTOR

Item No.	Description	Qty.	Unit	Currency	Supply of Equipment		Supply of Equipment		Foreign Currency (excluding VAT)	Local Currency (excluding VAT) Baht
					Foreign Supply		Local Supply			
					CFR Thai Port		Ex-works Price (excluding VAT) Baht			
					Unit Price	Amount	Unit Price	Amount		
1-1	110 Mvar, 525 kV, three-phase shunt reactor complete with insulating oil and accessories as per Ratings and Features RF RX951A	1		THB	69,500,000.00	69,500,000.00			XXXXX	XXXXX
1-2	Cost of installation supervisor for Item No. 1-1		Man-day	THB	XXXXXX	XXXXXX	XXXXXX	XXXXXX	556,000.00	
				THB	69,500,000.00	Baht		556,000.00	Baht	
Total Price for Schedule 1										

 นายสมชัย เจริญศรีเกษม
 ผู้อำนวยการฝ่ายวิศวกรรมระบบส่ง
 9 Apr 2026

Contract No.

Invitation to Bid No. SPSR-RX-01

ELECTRICITY GENERATING AUTHORITY OF THAILAND



BIDDING DOCUMENTS

SUPPLY OF 500 kV 110 MVAR SHUNT REACTOR

**SUPPLY AND INSTALLATION OF 500 kV
110 MVAR SHUNT REACTOR**

EGAT'S FUND

BIDDER : _____

(2026)

INVITATION TO BID NO. SPSR-RX-01
SUPPLY OF 500 kV 110 MVAR SHUNT REACTOR

SUPPLY AND INSTALLATION OF 500 kV
110 MVAR SHUNT REACTOR

EGAT'S FUND

CONTENTS

CONFIRMATION FORM

DISCOUNT FORM

ADDITIONAL REGULATION

IMPORTANT INFORMATION

DATA SHEET

SECTION A INVITATION TO BID

SECTION B INSTRUCTIONS TO BIDDERS

SECTION C PROPOSAL

SECTION D CONTRACT

SECTION E GENERAL CONDITIONS

SECTION F SPECIAL CONDITIONS

SECTION G RATINGS AND FEATURES

SECTION H BILL OF MATERIALS (None)

SECTION I SPECIFICATIONS

SECTION J DRAWINGS (None)

CONTENTS

<u>Article No.</u>	<u>Description</u>	<u>Page</u>
	Confirmation Form	-
	Discount Form	-
	Additional Regulation	1-11
	Important Information	i
	Data Sheet	i
<u>SECTION A : INVITATION TO BID</u>		
A-1	Invitation	A1
A-2	Eligibility of Bidders: General Requirements	A1
A-3	Eligibility of Bidders: Technical Requirements	A2
A-4	Joint Venture or Consortium	A4
A-5	Preparation and Delivery of Bids	A4
A-6	Availability of Bidding Documents	A5
<u>SECTION B : INSTRUCTIONS TO BIDDERS</u>		
	Overview of the Procurement Process	B1
B-1	Preparation of Bids	B2
B-2	Bid Prices	B3
B-3	Bid Security	B5
B-4	Validity of Bids	B6
B-5	Delivery of Bids	B6
B-6	Withdrawal of Bids	B6
B-7	Interpretation of Bidding Documents before Bid Opening	B6
B-8	Information to be Submitted with Bid	B7

<u>Article No.</u>	<u>Description</u>	<u>Page</u>
B-9	Deviations from Specifications	B9
B-10	Rejection of Bids	B9
B-11	Delivery Time	B9
B-12	Evaluation and Comparison of Bids	B10
B-13	Acceptance of Bids	B11
B-14	Appeal	B11
B-15	Award of Contract	B12
B-16	Bidder's Responsibility	B12
B-17	Supplemental Notices	B12
B-18	Cost of Bidding	B13
B-19	Cancellation of Bid	B13
	Specimen of Bid Security	B14
<u>SECTION C : PROPOSAL</u>		
C-1	Price Schedule	C1
C-2	Penalty for Equipment Not Meeting Guaranteed Characteristics	C2
C-3	Guaranteed Delivery Time	C2
C-4	Drawing and Document Submission Schedule	C2
C-5	Estimate of Deliveries	C2
C-6	Bid Security	C3
C-7	Supplemental Notices	C3
	Part 1 : Price Proposal	Project 1-C1
	Part 2 : Proposal Data	Part 2-C1
	Part 3 : Delivery Schedule and Distribution List	Part 3-C1

<u>Article No.</u>	<u>Description</u>	<u>Page</u>
--------------------	--------------------	-------------

SECTION D : CONTRACT

D-1	Contract Documents	D1
D-2	Acceptance of Proposal	D2
D-3	Agreement	D2
D-4	Obligation of Contractor	D2
D-5	Obligation of EGAT	D2
D-6	Mutual Obligations	D3
D-7	Deposit of Performance Security	D3
D-8	Assignment	D3
D-9	Notices	D3
D-10	Integration	D4
D-11	Counterpart	D4

SECTION E : GENERAL CONDITIONS

E-1	Definitions	E1
E-2	Intent of Contract Documents	E2
E-3	Applicable Law and Legal Jurisdiction	E3
E-4	Statutory Requirements	E3
E-5	Patents and Copyrights	E3
E-6	Subcontracts	E4
E-7	Export Charges	E4
E-8	Import Duty and Taxes	E4
E-9	Value Added Tax	E5
E-10	Income and Other Taxes	E6

<u>Article No.</u>	<u>Description</u>	<u>Page</u>
E-11	Fees and Duties	E7
E-12	Performance Security	E8
E-13	Inspection and Tests	E9
E-14	Preparation for Shipment and/or Delivery	E11
E-15	Clearance and Weight Limitations	E13
E-16	Shipment	E13
E-17	Documents Required for Each Shipment	E15
E-18	Force Majeure	E18
E-19	Transportation Insurance	E19
E-20	Transfer of Title	E19
E-21	Changes and Extra or Omitted Work	E19
E-22	Termination and Suspension of Contract	E20
E-23	Default and Termination	E20
E-24	Indemnification by the Contractor	E21
E-25	Limitation of Liability	E22
E-26	Consequential Damages	E22
E-27	Vesting of Contract in Receiver	E22
E-28	Extension of Time	E23
E-29	Failure to Meet Requirements	E23
E-30	Operation or Use of Unsatisfactory Equipment	E26
E-31	Dispute Resolution	E26
E-32	Language and Numbers	E26
	Specimen of Guarantee	E27
	Instructions for Packaging	E28

<u>Article No.</u>	<u>Description</u>	<u>Page</u>
--------------------	--------------------	-------------

SECTION F : SPECIAL CONDITIONS

F-1	Scope of Work	F1
F-2	Responsibility of Contractor	F1
F-3	Cooperation with Other Contractors	F1
F-4	Supervision of Installation	F2
F-5	Acceptance Tests	F3
F-6	Failure to Meet Performance Guarantees	F3
F-7	Acceptance Certificate	F3
F-8	Payment	F4
F-9	Liquidated Damages for Late Delivery of Equipment	F8
F-10	Maintenance Guarantee	F9
F-11	Drawings and Documents to be Furnished by Contractor	F11
F-12	Maintenance Security	F14
	Specimen of Maintenance Guarantee	F16
	Drawings and Documents to be Furnished by the Contractor (For Control and Protection Equipment)	F17
	Drawings and Documents to be Furnished by the Contractor (For All Equipment except Control and Protection Equipment)	F18

SECTION G : RATINGS AND FEATURES

G-1	Ratings and Features	G1
-----	----------------------	----

SECTION H : BILL OF MATERIALS (None)

- - -

Article No.

Description

Page

SECTION I : SPECIFICATIONS

I-1	Specifications	11
-----	----------------	----

SECTION J : DRAWINGS (None)

-	-	-
---	---	---

DRAFT

CONFIRMATION FORM

(INDIVIDUAL COMPANY / JOINT VENTURE)

INVITATION TO BID NO. SPSR-RX-01

SUPPLY OF 500 kV 110 MVAR SHUNT REACTOR

**SUPPLY AND INSTALLATION OF 500 kV
110 MVAR SHUNT REACTOR**

By signing in the space provided below, we confirm that:-

- According to “Eligibility of Bidders” and in addition to the Documentary List attached to the bidding documents, we are not a Jointly Interested Bidder with the other bidders as from the date of EGAT’s issuance of the subject Invitation and are not a person who undertakes any actions as an “Obstruction of Fair Price Competition”.
- According to Article B-8. Information to be Submitted with Bid, we confirm
 - Registration with the Revenue Department as a value added tax registrant in Thailand as per certificate of value added tax registration (จพ.20) attached.
 - Non-Registration as a value added tax registrant in Thailand, but will register later.
 - Non-Registration as a value added tax registrant in Thailand and will not register.

Confirmed :

.....

By :

Title :

Date :

CONFIRMATION FORM

(CONSORTIUM)

INVITATION TO BID NO. SPSR-RX-01

SUPPLY OF 500 kV 110 MVAR SHUNT REACTOR

**SUPPLY AND INSTALLATION OF 500 kV
110 MVAR SHUNT REACTOR**

Member No. ... of the consortium:

By signing in the space provided below, we confirm that:-

- According to “Eligibility of Bidders” and in addition to the Documentary List attached to the bidding documents, we are not a Jointly Interested Bidder with the other bidders as from the date of EGAT’s issuance of the subject Invitation and are not a person who undertakes any actions as an “Obstruction of Fair Price Competition”.
- According to Article B-8. Information to be Submitted with Bid, we confirm
 - Registration with the Revenue Department as a value added tax registrant in Thailand as per certificate of value added tax registration (ภพ.20) attached.
 - Non-Registration as a value added tax registrant in Thailand, but will register later.
 - Non-Registration as a value added tax registrant in Thailand and will not register.

Confirmed :

.....

By :

Title :

Date :

DISCOUNT FORM
(Excluding VAT)

INVITATION TO BID NO. SPSR-RX-01

SUPPLY OF 500 kV 110 MVAR SHUNT REACTOR

**SUPPLY AND INSTALLATION OF 500 kV
110 MVAR SHUNT REACTOR**

Bidder : _____

By signing in the space provided below, we confirm that:-

- we offer no discount.
- we offer discount(s) as follows:

Details of discount	Currency	Amount

Remarks :

- ***The Bidder shall apply discount(s) on any item(s), schedule(s), or the total price, excluding Value Added Tax (VAT).***
- The above discount(s) shall not be subject to any conditions. Discount with conditions shall not be considered.
- This Discount Form, together with Bidder's Summary of Bid Price, will be publicly presented on a screen to all Bidders in the bid opening room at the time of bid opening.

Confirmed by authorized person(s):

.....

By :

Title :

Date :

Additional Regulation

This Regulation shall apply to the Enquiry, Bid for Supply, Lease, Hire of Work, or Hire of Consultant by Way of Selection.

1. Attachments

1.1 Definitions

1.1.1 Jointly Interested Bidder

1.1.2 Obstruction of Fair Price Competition

1.2 Documentary List

2. Bidder's Qualifications

2.1 The Bidder shall professionally be in the business of providing materials or services or leasing or consultancy services, as the case may be, and shall not be named in the list of work abandoners published by the Permanent Secretary, Ministry of Finance, and/or in the debarment list and/or the list of work abandoners declared by EGAT according to Article 5 of this Regulation.

2.2 The Bidder shall not be a Jointly Interested Bidder with other bidders as from the date of EGAT's issuance of the Invitation for Bid/Enquiry or the Invitation Letter/ Terms of Reference for the consultancy services, as the case may be, or shall not be a person who undertakes any action as an "Obstruction of Fair Price Competition" described in Article 1.1 – Definitions.

2.3 The Bidder shall not have EGAT's personnel involve in his business as shareholder having voting right that can control his business, director, manager, officer, employee, agent or consultant except for the ones who are officially ordered by EGAT to act or participate therein.

3. Information to be Submitted with Bid

The Bidder shall submit with his bid the documents according to Article 1.2 - Documentary List, including but not limited to, the following documents :-

3.1 Where the Bidder is a juristic person :

(a) ordinary partnership or limited partnership

a certified copy of affidavit of incorporation, name list of managing partners, list of persons entrusted with controlling power (if any), as well as a certified copy of registration for value added tax (if any).

(b) limited company or public limited company

a certified copy of affidavit of incorporation, memorandum of association, name list of managing directors, list of persons entrusted with controlling power (if any) and name list of major shareholders, as well as a certified copy of registration for value added tax (if any).

Such certified copy of affidavit of incorporation with the validity of not more than six (6) months from the date of certification to the opening date of Bid/Enquiry or the date of Invitation Letter/Terms of Reference in case of consultancy services, as the case may be, shall certify at least the following information :

- (i) Type of a juristic person : an ordinary partnership, a limited partnership, a limited company, a public limited company,
- (ii) Name according to (i),
- (iii) Number and names of managing partners or managing directors,
- (iv) Number and names of managing partners or managing directors authorized to act on behalf of the company,
- (v) Amount of shareholders' equity or registered capital,
- (vi) Authority of managing partner in case of partnership,
- (vii) Location of head office,
- (viii) Registration purposes,

- (ix) Scope of work indicated in business permit license of a foreign juristic person who registers in Thailand,
- (x) Other documents e.g. changes or additions to the above documents, branches (if any).

3.2 Where the Bidder is a natural person or a group of persons other than a juristic person :

a certified copy of :

- identity card **or passport (if non-Thai national)**
- partnership agreement or contract (if any)
- partners' identity cards **or passport (if non-Thai national)**
- registration required by Ministry of Commerce of Thailand
- registration for value added tax (if any)

3.3 Where the Bidder is a joint venture / consortium :

a certified copy of :

- association agreement
- identity card or passport (if non Thai national)
(The participant in the joint venture or consortium is not a juristic person.)
- all documents specified in *Item 3.1* of Additional Regulation
(The participant in the joint venture or consortium is a juristic person.)

3.4 Other documentary evidence as required per *Item 3, 6 or 8* of Documentary List (if any).

4. Preliminary Examination

4.1 EGAT shall examine the qualification of all bidders to determine whether any bidder is a Jointly Interested Bidder as from the date of EGAT's issuance of the Invitation for Bid/Enquiry or the Invitation Letter/Terms of Reference for the consultancy services, as the case may be, and/or undertakes any action as an "Obstruction of Fair Price Competition" before or during the bid opening. If there is evidence showing that any bidder is a Jointly Interested Bidder or undertakes any action as an "Obstruction of Fair Price Competition", EGAT shall delete his name from the list of bidders and inform such bidder by written notice hereof.

4.2 The Bidder whose name is deleted according to Article 4.1, may, within fifteen (15) calendar days from the date of receipt of EGAT's written notice, appeal to EGAT, explaining reasons together with relevant documents for EGAT's reconsideration.

In case EGAT agrees with the objection of the appellant but considers that the cancellation of enquiry/bidding will be beneficial to EGAT, EGAT may, at its sole discretion, cancel such bid. In the event that the Bidder who undertakes any action as an "Obstruction of Fair Price Competition" does not appeal or, after his appeal, EGAT does not agree with his objection, such Bidder shall be regarded as a work abandoner.

EGAT's decision shall be notified to the appellant in writing and such decision shall be final and conclusive.

5. Reservation of the Right for Proposal and Others

In case any juristic person is regarded as a work abandoner by EGAT and such abandonment is caused by the manager, the managing partner, the managing director, the executive or the person authorized to manage the business of that juristic person, EGAT shall also include his name as a work abandoner.

In case any juristic person is regarded as a work abandoner by EGAT, such decision shall also be applied to other juristic persons of the same business where its manager, managing partner, managing director, executive, or person authorized to manage the business is the same person who is the manager, managing partner, managing director, executive, or person authorized to manage the business of the juristic person who is regarded as a work abandoner by EGAT as aforesaid.

In case any natural person is regarded as a work abandoner by EGAT, such decision shall also be applied to other juristic persons who submit the proposal and have such natural person as the manager, managing partner, managing director, executive or person authorized to manage the business of such juristic persons

1.1 Definitions

These definitions shall apply to the Enquiry, Bid for Supply, Lease, Hire or Work, or Hire of Consultant by Way of Selection.

1.1.1 **“Jointly Interested Bidder”** means a natural person or juristic person who submits bid to EGAT for the supply of goods, lease, hire of work, or hire of consultant by way of selection, as the case may be, and who has an interest, either directly or indirectly, in the business of another natural person or juristic person whose bid is also submitted to EGAT in this bidding.

The interest, either direct or indirect, in another natural person or juristic person as aforesaid includes the relationship in the following manners :

- (1) Management relationship, whereby the manager, the managing partner, the managing director, the executive or the person authorized to manage the business of a natural person or a juristic person has the power, or is able to exercise the power, in managing the business of the other one or more natural persons or juristic persons whose bids are also submitted to EGAT in this bidding.
- (2) Capital relationship, whereby a partner in an ordinary partnership or a partner with unlimited liability in a limited partnership or a major shareholder in a limited company or a public limited company is a partner in the other one or more ordinary partnerships or limited partnerships, or is a major shareholder in the other one or more limited companies or public limited companies whose bids are also submitted to EGAT in this bidding.
- (3) Cross relationship between (1) and (2), whereby the manager, managing partner, managing director, executive or person authorized to manage the business of a natural person or juristic person is a partner in the other one or more ordinary partnerships or limited partnerships, or is a major shareholder in the other one or more limited companies or public limited companies whose bids are also submitted to EGAT in this bidding, or *vice versa*.

“Major shareholder” means a shareholder who holds more than twenty five (25) percent of stake in such an enterprise or at another percentage determined by the Governor as he deems expedient for some types or sizes of enterprises.

Holding of position, being a partner or shareholding as aforesaid by the spouse or minor of the person in (1), (2) or (3) shall be deemed the holding of position, being a partner or shareholding by such person.

If any bidder uses the name of another person as the manager, managing partner, managing director, executive, partner or shareholder, but in which case he himself in fact exercises the power in management or he himself is the real partner or shareholder of the partnership or limited company or public limited company, as the case may be, and the related partnership or limited company or public limited company whose bid is also submitted to EGAT in this bidding, that bidder shall be deemed to have a relationship under (1), (2) or (3), as the case may be.

1.1.2 ***“Obstruction of Fair Price Competition”*** means any act committed by a bidder or bidders causing hindrance or obstruction or impeding the opportunity for fair price competition in the tendering of bid to EGAT, whether done by collusion, or by granting, requesting, or agreeing to grant, demand, accept or agreeing to accept money or property or other benefit or by committing an act of violence or by threatening to commit an act of violence or presenting a false document or doing any act in bad faith, with the objective of acquiring benefit among the other bidders or in order to give benefit to any specific bidder so that such person will be entitled to enter into a contract with EGAT or in order to avoid fair price competition, or in order to take advantage to EGAT which not being usual business practices.

DRAFT

1.2 Documentary List

This documentary list shall apply to the Enquiry, Bid for Supply, Lease, Hire of Work, or Hire of Consultant by Way of Selection.

	No. of page(s)	For EGAT only	
<u>Thai National Bidder</u>			
[] 1. Where the Bidder is a natural person or a group of persons other than a juristic person			
() (a) Natural Person		Yes	No
- Certified copy of identity card		<input type="checkbox"/>	<input type="checkbox"/>
() (b) Group of persons			
- Certified copy of partnership agreement or contract (if any)		<input type="checkbox"/>	<input type="checkbox"/>
- Certified copy of identity card(s) of partners or related documents according to Item 2 (a) and (b) of each participant of the group		<input type="checkbox"/>	<input type="checkbox"/>
[] 2. Where the Bidder is a juristic person			
() (a) Ordinary partnership or limited partnership			
- Certified copy of affidavit of incorporation		<input type="checkbox"/>	<input type="checkbox"/>
- Name list of managing partners and list of persons entrusted with controlling power (if any)		<input type="checkbox"/>	<input type="checkbox"/>
(Please fill in the form on page 10.)			
() (b) Limited company or public limited company			
- Certified copy of affidavit of incorporation		<input type="checkbox"/>	<input type="checkbox"/>
- Memorandum of Association		<input type="checkbox"/>	<input type="checkbox"/>
- Name list of managing directors and list of persons entrusted with controlling power (if any)		<input type="checkbox"/>	<input type="checkbox"/>
(Please fill in the form on page 10.)			
- Name list of major shareholders		<input type="checkbox"/>	<input type="checkbox"/>
(Please fill in the form on page 11.)			
[] 3. Other documents (if any)			
() Certified copy of any other registration required by Ministry of Commerce of Thailand		<input type="checkbox"/>	<input type="checkbox"/>
() Certified copy of registration for value added tax		<input type="checkbox"/>	<input type="checkbox"/>
()		<input type="checkbox"/>	<input type="checkbox"/>
()		<input type="checkbox"/>	<input type="checkbox"/>

No. of page(s)

For EGAT only

Non-Thai National Bidder

<p>[] 4. Where the Bidder is a natural person or a group of persons other than a juristic person</p> <p>() (a) Natural Person</p> <p style="padding-left: 20px;">- Certified copy of passport</p> <p>() (b) Group of persons</p> <p style="padding-left: 20px;">- Certified copy of partnership agreement or contract (if any)</p> <p style="padding-left: 20px;">- Certified copy of passport of partners or related documents according to Item 5 of each participant of the group</p> <p>[] 5. Where the Bidder is a juristic person</p> <p style="padding-left: 20px;">- Certified copy of affidavit of incorporation</p> <p style="padding-left: 20px;">- Name list of managing partners, directors, etc., as the case may be, and list of persons entrusted with controlling power (if any)</p> <p style="padding-left: 20px;">- Memorandum of Association (if any) (Please fill in the form on page 10.)</p> <p style="padding-left: 20px;">- Name list of major shareholders (if any) (Please fill in the form on page 11.)</p> <p>[] 6. Other documents (if any)</p> <p>()</p> <p>()</p> <p>()</p> <p>()</p> <p>()</p>	<table border="1" style="width: 100%; border-collapse: collapse;"> <thead> <tr> <th colspan="2"></th> <th style="text-align: center;">Yes</th> <th style="text-align: center;">No</th> </tr> </thead> <tbody> <tr> <td style="width: 50%;"></td> <td style="width: 50%;"></td> <td style="text-align: center;"><input type="checkbox"/></td> <td style="text-align: center;"><input type="checkbox"/></td> </tr> <tr> <td style="width: 50%;"></td> <td style="width: 50%;"></td> <td style="text-align: center;"><input type="checkbox"/></td> <td style="text-align: center;"><input type="checkbox"/></td> </tr> <tr> <td style="width: 50%;"></td> <td style="width: 50%;"></td> <td style="text-align: center;"><input type="checkbox"/></td> <td style="text-align: center;"><input type="checkbox"/></td> </tr> <tr> <td style="width: 50%;"></td> <td style="width: 50%;"></td> <td style="text-align: center;"><input type="checkbox"/></td> <td style="text-align: center;"><input type="checkbox"/></td> </tr> <tr> <td style="width: 50%;"></td> <td style="width: 50%;"></td> <td style="text-align: center;"><input type="checkbox"/></td> <td style="text-align: center;"><input type="checkbox"/></td> </tr> <tr> <td style="width: 50%;"></td> <td style="width: 50%;"></td> <td style="text-align: center;"><input type="checkbox"/></td> <td style="text-align: center;"><input type="checkbox"/></td> </tr> <tr> <td style="width: 50%;"></td> <td style="width: 50%;"></td> <td style="text-align: center;"><input type="checkbox"/></td> <td style="text-align: center;"><input type="checkbox"/></td> </tr> <tr> <td style="width: 50%;"></td> <td style="width: 50%;"></td> <td style="text-align: center;"><input type="checkbox"/></td> <td style="text-align: center;"><input type="checkbox"/></td> </tr> <tr> <td style="width: 50%;"></td> <td style="width: 50%;"></td> <td style="text-align: center;"><input type="checkbox"/></td> <td style="text-align: center;"><input type="checkbox"/></td> </tr> </tbody> </table>			Yes	No			<input type="checkbox"/>	<input type="checkbox"/>			<input type="checkbox"/>	<input type="checkbox"/>			<input type="checkbox"/>	<input type="checkbox"/>			<input type="checkbox"/>	<input type="checkbox"/>			<input type="checkbox"/>	<input type="checkbox"/>			<input type="checkbox"/>	<input type="checkbox"/>			<input type="checkbox"/>	<input type="checkbox"/>			<input type="checkbox"/>	<input type="checkbox"/>			<input type="checkbox"/>	<input type="checkbox"/>
		Yes	No																																						
		<input type="checkbox"/>	<input type="checkbox"/>																																						
		<input type="checkbox"/>	<input type="checkbox"/>																																						
		<input type="checkbox"/>	<input type="checkbox"/>																																						
		<input type="checkbox"/>	<input type="checkbox"/>																																						
		<input type="checkbox"/>	<input type="checkbox"/>																																						
		<input type="checkbox"/>	<input type="checkbox"/>																																						
		<input type="checkbox"/>	<input type="checkbox"/>																																						
		<input type="checkbox"/>	<input type="checkbox"/>																																						
		<input type="checkbox"/>	<input type="checkbox"/>																																						

Thai and Non-Thai National Bidder

		No. of page(s)	For EGAT only	
			Yes	No
[]	7. Where the Bidder is a joint venture / consortium			
	- Certified copy of association agreement	<input type="checkbox"/>	<input type="checkbox"/>
()	(a) If participant of a joint venture / consortium is not a juristic person			
	(i) Thai national			
	- Certified copy of identity card	<input type="checkbox"/>	<input type="checkbox"/>
	(ii) Non-Thai national			
	- Certified copy of passport	<input type="checkbox"/>	<input type="checkbox"/>
()	(b) If participant of a joint venture / consortium is a Thai-national juristic person			
	() (i) Ordinary partnership or limited partnership			
	- Certified copy of affidavit of incorporation	<input type="checkbox"/>	<input type="checkbox"/>
	- Name list of managing partners, and list of persons entrusted with controlling power (if any) (Please fill in the form on page 10.)	<input type="checkbox"/>	<input type="checkbox"/>
	() (ii) Limited company or public limited company			
	- Certified copy of affidavit of incorporation	<input type="checkbox"/>	<input type="checkbox"/>
	- Memorandum of Association	<input type="checkbox"/>	<input type="checkbox"/>
	- Name list of managing directors, and list of persons entrusted with controlling power (if any) (Please fill in the form on page 10.)	<input type="checkbox"/>	<input type="checkbox"/>
	- Name list of major shareholders (Please fill in the form on page 11.)	<input type="checkbox"/>	<input type="checkbox"/>

		No. of page(s)	For EGAT only	
			Yes	No
()	(c) If member of a joint venture / consortium is a Non-Thai national juristic person			
-	Certified copy of affidavit of incorporation	<input type="checkbox"/>	<input type="checkbox"/>
-	Name list of managing partners, directors, etc., as the case may be, and list of persons entrusted with controlling power (if any) (Please fill in the form on page 10.)	<input type="checkbox"/>	<input type="checkbox"/>
-	Memorandum of Association (if any)	<input type="checkbox"/>	<input type="checkbox"/>
-	Name list of major shareholders (if any) (Please fill in the form on page 11.)	<input type="checkbox"/>	<input type="checkbox"/>
[]	8. Other documents (if any)			
()	Certified copy of any other registration required by Ministry of Commerce of Thailand	<input type="checkbox"/>	<input type="checkbox"/>
()	Certified copy of registration for value added tax in Thailand	<input type="checkbox"/>	<input type="checkbox"/>
()	<input type="checkbox"/>	<input type="checkbox"/>
()	<input type="checkbox"/>	<input type="checkbox"/>
()	<input type="checkbox"/>	<input type="checkbox"/>

We hereby confirm that all documents detailed above are true and correct.

Signed

(Name of Bidder)

stamp company seal (if any)

List of Names of Manager / Managing Partner / Managing Director / Executive /
 Person Who Is Authorized to Manage the Business
 (Relationship in Management)

Bidder shall fill in and submit this form with his bid

Enquiry / Bid No : Enquiry / Bid Opening Date :

Name of Company / Partnership / Juristic Person :

No.	Name – Surname	Position	Name – Surname of Spouse	Name – Surname of Minor

We hereby confirm that all documents submitted are true and correct.

Signed _____
 (Name of Bidder)

Stamp company seal (if any)

Remarks

1. The unused wordings shall be struck out.
2. Duplicate this page as necessary.

List of Partner in Ordinary Partnership / Partner with Unlimited Liability in Limited Partnership /
Major Shareholder in Limited Company or Public Limited Company
(Relationship in Capital)

Bidder shall fill in and submit this form with his bid

Enquiry / Bid No. : Enquiry / Bid Opening Date :

Name of Company / Partnership / Juristic Person :

Registered Capital : (currency)..... Number of Share : Price per Share : (currency).....

No.	Name - Surname	Position	Number of Share (%) or Amount of Shareholder's Equity	Name – Surname of Spouse	Number of Share (%) or Amount of Shareholder's Equity	Name – Surname of Minor	Number of Share (%) or Amount of Shareholder's Equity

We hereby confirm that all documents submitted are true and correct.

Signed _____

(Name of Bidder)

Stamp company seal (if any)

Remarks

1. The unused wordings shall be struck out.
2. "Major Shareholder" means a shareholder who holds more than twenty-five (25) per cent of stake in an enterprise. The shareholding of spouse or minor of a person shall be regarded as being the shareholding of such person. In case of no major shareholder, please specify "No major shareholder" in the tabulation above.
3. Duplicate this page as necessary.
4. The Bidder shall submit List of Names of Manager/ Managing Partner/ Managing Director/ Executive/ Person Who Is Authorized to Manage the Business (Relationship in Management)/ and List of Partner in Ordinary Partnership/ Partner with Unlimited Liability in Limited Partnership/ Major Shareholder in Limited Company or Public Limited Company (Relationship in Capital) of the Bidder as per page 10-11 of this Additional Regulation.

Important Information
for
Invitation to Bid No. SPSR-RX-01

The purpose of this section is to inform the Bidders to **carefully study** the details of the revised terms and conditions in the bidding documents. The following provisions have been **recently revised** as stated hereunder:

Article A-5. Preparation and Delivery of Bids and Article B-1. Preparation of Bids

Details on how to prepare the proposal have been revised. Bids shall be prepared in accordance with the Instructions to Bidders contained in the Bidding Documents in one (1) original hard copy and one (1) electronic copy contained in USB flash drive.

Article A-5. Preparation and Delivery of Bids

Details of bid opening time and place shall be specified in the Tentative Schedule.

Article A-6. Availability of Bidding Documents

Availability of Bidding Documents has been changed from CD-ROM to electronic files for download via link provided by EGAT.

Channel of Documents Submission

For channel of document submission in the hereunder Articles, facsimile and telex has been replaced with letters submitted electronically or electronic mails (E-mails).

- Article B-1. Preparation of Bids
- Article B-4. Validity of Bids
- Article D-9. Notices
- Article E-17. Documents Required for Each Shipment
- Article F-8. Payment

Article B-2. Bid Prices

For Source of Supply and Service b., Prices for Equipment manufactured outside Thailand (imported Equipment) shall be firm, stated both on FOB Port of Shipment/Vessel and CFR Thai Port basis, and quoted in Thai baht, US dollar, euro, Japanese yen, renminbi (Chinese yuan), or in the Bidder's or Manufacturer's home currency only if his currency trading is prevailed at the time of bidding in any international market other than in Bidder's or Manufacturer's home country.

The following paragraph has also been added :-

“Prices for the following Equipment manufactured outside Thailand which was imported before the bid opening date shall be firm ex-works and quoted in Thai baht, provided that the Bidder shall submit any document(s) evidencing the importation date of such Equipment:

- Power Fuse
- Stationary Battery and Battery Charger
- Insulator for substation
- Cable Termination
- Compression Connector and Miscellaneous Hardware
- Bus Fittings
- Grounding Material
- Substation Miscellaneous”

Article E-14. Preparation for Delivery

The Instructions for Packaging attached at the end of Section E. General Conditions has been revised in item 8. Shunt Capacitor Bank.

Article E-16. Shipment

The Maritime Promotion Bureau has been updated to the Maritime Promotion Division and its contact information has also been updated.

Article F-8. Payment

After each payment is made, the Contractor or beneficiary shall issue and submit the receipt to EGAT as detailed in the paragraph added at the end of this article.

DRAFT

DATA SHEET

DATA SHEET

for

Invitation to Bid No. SPSR-RX-01

This section consists of provisions that are specific to each procurement and supplement the information or requirements included in bidding documents.

Article A-1. Invitation

Insert the following as the second and third paragraphs of this article respectively:

“ The Letter of Award of Contract to be issued to the successful Bidder will be made after EGAT obtains the Project approval from the Government of Thailand, and the approval for Project implementation from the Government’s authority and/or other related entities as required (if any) by Thai laws.

Unless EGAT gets approval as such, the Project and the work under this invitation has to be cancelled. In the event such cancellation is required, all costs incurred by the Bidder in purchasing documents and preparing his bid shall be at his own account and will not be reimbursed by EGAT.”

Article B-3. Bid Security

The amount of bid security shall be USD 114,930.- or THB 3,770,000.-.

Article B-4. Validity of Bids

The validity of the bid shall be for one hundred and fifty (150) Days from the date specified for opening of bid.

Article B-8. Information to be Submitted with Bid

Item m. is not applicable

Article B-12. Evaluation and Comparison of Bids:

The evaluation of bid prices shall be on schedule basis.

Article E-29. Failure to Meet Requirements and F-10. Maintenance Guarantee

Maintenance Guarantee Period

- For all Equipment except Shunt Reactor, 200 MVA 230 kV and above Power Transformer and 500 kV System Voltage Equipment

The Contractor shall guarantee the proper functioning of Equipment for a period of one (1) Year except the following Equipment the guarantee period of which shall be as follows :

<u>Equipment</u>	<u>Period of Guarantee (Year)</u>
- Fault Recording System	2
- Control and Protection System	2

- For Shunt Reactor, 200 MVA 230 kV and above Power Transformer and 500 kV System Voltage Equipment

The Contractor shall guarantee the proper functioning of Equipment for a period of five (5) Years.

Defective Equipment to be replaced with the whole new set

For GIS, Power Transformer, Power Circuit Breaker, Shunt Reactor, in case EGAT, at its sole discretion, requires the Contractor to replace any defected Equipment, the Contractor shall replace the Equipment with the whole new set as specified in Failure to Meet Requirements in section E and Maintenance Guarantee in section F.

Article F-9. Liquidated Damages for Late Delivery of Equipment

The Liquidated Damages shall be at the rate of one-tenth of one (0.10) per cent of the price of Equipment not timely delivered for each Day of delay. This sum is payable regardless of the actual loss and/or damages incurred.

DRAFT

SECTION A
INVITATION TO BID

INVITATION TO BID NO. SPSR-RX-01
SUPPLY OF 500 kV 110 MVAR SHUNT REACTOR
SUPPLY AND INSTALLATION OF 500 kV
110 MVAR SHUNT REACTOR

A-1. Invitation

The Electricity Generating Authority of Thailand (EGAT) hereby invites sealed bids for furnishing and delivering of 500 kV 110 MVAR Shunt Reactor under Supply and Installation of 500 kV 110 MVAR Shunt Reactor hereinafter called Equipment in accordance with the terms, conditions and Specifications described in these Bidding Documents.

A-2. Eligibility of Bidders: General Requirements

All Bidders shall meet the following requirements; failure to so comply shall constitute sufficient ground for rejection.

- a. The Bidder shall be a partnership, firm or company, either alone or in joint venture or in consortium.
- b. The Bidder must have purchased the bidding documents from EGAT. For a joint venture or a consortium, only one (1) member of the joint venture or consortium is required to purchase the bidding documents.

In case the Bidder's name is not exactly the same as the purchaser's name, the purchaser shall notify EGAT of the name of the Bidder in writing prior to the bid opening time.

- c. The Bidder shall be well-established and maintain a permanent place of business. For a joint venture or consortium, all members of the joint venture or consortium are required to meet this qualification.
- d. The Bidder shall not be named in the List of Work Abandoners published by the Permanent Secretary, Ministry of Finance, and/or in the Debarment List and/or in the List of Work Abandoners declared by EGAT.

- e. For the Bidder who changes name before submitting the bid, his experience records in previous name shall be considered as the experience records of the Bidder.
- f. The Bidder shall not be a Jointly Interested Bidder with other Bidders as from the date of EGAT's issuance of this invitation to bid, or shall not be a person who undertakes any action as an "Obstruction of Fair Price Competition" as defined in Additional Regulation for this invitation.
- g. The Bidder shall not either be EGAT's consultant or involve in EGAT's consultancy company under this invitation, or have EGAT's personnel involved in his business as shareholder having voting right that can control his business, director, manager, officer, employee, agent or consultant except the ones who are officially ordered by EGAT to act or participate therein.
- h. The Bidder shall not be the person who is privileged or protected not to be taken any legal proceeding under Thai court; provided that such Bidder's government declares that such special privilege is waived.
- i. In case of a joint venture or consortium, the Bidder shall carry out all the provision of the Equipment and all Work under such formation from the time of bidding until the fulfillment of the Contract and the parties to the joint venture or the consortium shall accept joint and several liability for performing all obligations under the bid and the Contract.
- j. The Bidder shall not propose to supply the Equipment from the country under the state of war whether declared or not.
- k. The Bidder shall have adequate fund to meet financial obligations incidental to this Contract.
- l. The Bidder shall submit documentary evidence established in accordance with Article B-8. Information to be Submitted with Bid to demonstrate the Bidder's sufficient eligibility to bid and qualification to perform the Contract.

A-3. Eligibility of Bidders: Technical Requirements

- I. All Bidders shall meet the following requirements; failure to so comply shall constitute sufficient ground for rejection.**
 - a. The Bidder shall manufacture or supply the Equipment or Work as required under this invitation to bid.

- b. If the Bidder is a new company formed by acquisition of or merger with other companies or business units before submitting the Bid, the experience records of any of such previous companies or business units that meet the requirements set forth herein are acceptable as the experience records of the Bidder.
- c. The Bidder shall have no just or proper claims pending against the Bidder with respect to breach in the performance of contract on other similar works awarded by EGAT. If the Bidder is a new company formed by acquisition of or merger with other companies or business units, the pending claim of any of such previous companies or business units shall be considered pending claim of the Bidder.
- d. The Bidder shall have sufficient capacity to carry out the Work.
- e. The Bidder shall propose Equipment manufactured by the qualified manufacturers who shall fulfill the following requirements :
 - 1. Being well-established and maintaining a permanent place of business.
 - 2. The manufacturer shall have the experience records that meet the requirements set forth herein.

Reference records of either parent or affiliated companies shall not be considered as the records of such manufacturer.

- 3. If the Manufacturer is a new company formed by acquisition of or merger with other companies or business units, and any of such previous companies or business units has the experience records that meet the requirements set forth herein, such experience records are acceptable as the experience records of the new company, provided that each item of the equipment to be supplied under this bid shall be manufactured from the same source of supply as indicated in each of such relevant supply records as described in Item e.5 below. Otherwise, it shall not be acceptable and shall be sufficient grounds for rejection.

For the avoidance of doubt, it is not allowed to combine the experience records of the previous companies or business units in order to meet the experience requirements.

- 4. Regularly manufacturing of Equipment of the type and ratings proposed.
- 5. Having minimum experience in manufacturing of the following reactors with minimum BIL rating of winding of 1425 kV with at least five consecutive years of successful operation/use in overseas (not his own country). A combination of three-phase reactors and reactor banks can be considered.

5.1 Five units of three-phase reactor having the minimum capacity of 100 MVAR

OR

- 5.2 Five reactor banks (each bank comprises three single-phase reactors) with the minimum capacity of each bank not less than 100 MVAR
6. Proposing the manufacturer who has no just or proper pending claims against Equipment on other similar works.

In case the manufacturer is a new company formed by acquisition or merger with other companies or business units, the pending claim of any of such previous companies or business units shall be considered pending claim of the manufacturer.

II. All Bidders should preferably meet the following technical requirements; failure to so comply may constitute sufficient ground for rejection.

- a. Proposing the Equipment from the manufacturer having a certificate indicating that his system has been satisfactorily developed and implemented conforming to ISO 9001.

A-4. Joint Venture or Consortium

In the event that the successful Bidder is a joint venture or a consortium formed of two or more companies, EGAT requires that the parties to the joint venture or the consortium accept joint and several liability for all obligations under the Contract.

A-5. Preparation and Delivery of Bids

Bids shall be prepared in accordance with the Instructions to Bidders contained in the Bidding Documents in one (1) original *hard copy and one (1) electronic copy contained in USB flash drive*, in English, on the bid forms included for this purpose and shall be accompanied with a bid security as required under Article B-3. Bid Security in a separate sealed envelope.

For preparation of original hard copy, each page of the original hard copy shall be marked with the volume number and the page number in the lower right-hand corner, for example, Volume 1 of 10 and Page 1 of 100.

For preparation of electronic copy, each volume of the signed original hard copy shall be scanned into one (1) PDF file and each PDF file shall be named according to the volume number.

The USB flash drive shall contain electronic files of the proposal in the following formats :-

- PDF files of all pages of each volume of the proposal, and

- Excel files of filled-in Proposal Data, and

- Excel files of filled-in Price Schedule

In the event of any discrepancy between the original hard copy and the electronic file(s), the original hard copy shall govern.

The envelope of the bids will be marked in capital letters in the lower left-hand corner as follows :

INVITATION TO BID NO. SPSR-RX-01
SUPPLY OF 500 kV 110 MVAR SHUNT REACTOR
SUPPLY AND INSTALLATION OF 500 kV
110 MVAR SHUNT REACTOR

and shall be addressed and delivered to **EGAT**, on or before 10:00 a.m., Bangkok Standard Time, *see Tentative Schedule*

If the envelope(s) is not sealed, marked and addressed as required above, EGAT will assume no responsibility for the bid misplacement or premature opening.

Bids will be opened publicly at the **place and** time specified **in Tentative Schedule**.

Bids received after the time stipulated herein shall be rejected and returned unopened.

A-6. Availability of Bidding Documents

The Bidding Documents are available for examination **and online purchase at <http://www4.egat.co.th/fprocurement/biddingeng/>** and can be obtained **by downloading via link provided by EGAT** upon payment to EGAT, non-refundable, in the amount of USD 70.- or Baht 2,000.-. These prices include the value added tax.

DRAFT

SECTION B
INSTRUCTIONS TO BIDDERS

INSTRUCTIONS TO BIDDERS

Overview of the Procurement Process

Bid prices and the Contract Price shall include value added tax (VAT) imposed under the law of Thailand. The medium cost announced by EGAT is inclusive of VAT and other relevant expenses.

The amounts of performance security, maintenance security, and liquidated damages shall also be based on the Contract Price which is inclusive of VAT (if any).

For evaluation and comparison of Bids, the bid price shall be evaluated according to the conditions specified in the bidding document.

The procurement process is summarized in the following diagram.

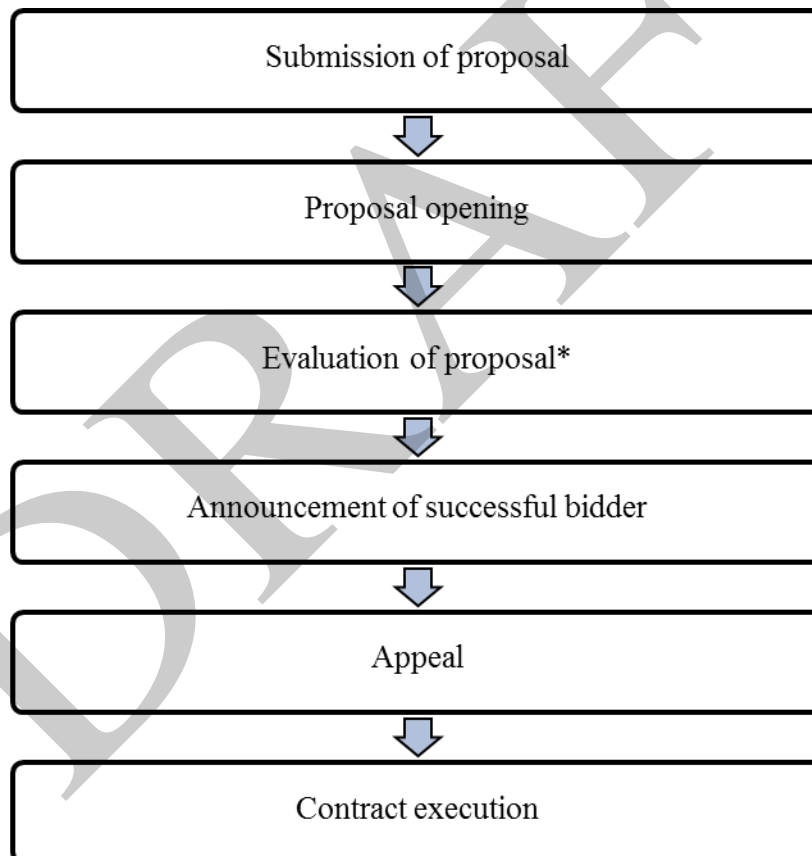

*Remarks

1. The Bidder shall be deemed to have carefully examined all of the terms, conditions and Specifications of the Bidding Documents.
2. EGAT will take into consideration the conformity of the bid to the requirements of the Bidding Documents as well as the suitability for the purpose intended.
3. EGAT will not be bound to accept the bid with the lowest indicated cost. EGAT reserves the right to accept the bid which in its judgement is the lowest evaluated bid.

B-1. Preparation of Bids

- a. Bids shall be prepared in English, in one (1) original *hard copy clearly marked “Original” and one (1) electronic copy contained in USB flash drive*, submitted at the place and time specified for receipt of bids.

In the event of any discrepancy between *the original hard copy and the electronic copy, the original hard copy* shall govern.

For Proposal Data, Bidder shall fill in information of Proposal Data in Excel files contained in the Bidding Documents, and submit one (1) original hard copy with the PDF and Excel files in USB flash drive to EGAT at the same time of bid submission.

For price quotation, Bidder *shall fill in* bid prices in an Excel files of Price Schedules contained in the Bidding Documents in accordance with Price Quotation Instructions in Section C, Part 1: Price Proposal, and submit one (1) original *hard copy with the PDF and Excel files in USB flash drive* to EGAT at the same time of bid submission.

VAT at the prevailing rate shall be filled automatically in the Summary of Bid Price of the price schedule in the Excel file subject to Article B-2. Bid Prices.

However, in case Bidder is a consortium formed of two or more companies, Bidder must also submit one (1) original hard copy *with the PDF and Excel files* of price schedules of the Work performed by each member of the consortium in addition to hard copies *with the PDF and Excel files* of the total bid price as specified above.

If any discrepancy between the bid prices of the Work performed by each member of the consortium and the bid prices of the Bidder occurs, the bid prices of the Bidder shall govern and the bid prices of the Work performed by each member of the consortium shall be adjusted accordingly.

In the event of discrepancy between the original hard copy *and the PDF or Excel files* submitted, the original hard copy shall govern.

- b. Bidder shall not submit more than two (2) proposals and the proposal(s) to be submitted shall conform to the specifications. In case of any deviation from the specifications, Bidder shall follow the provisions under Article B-9. Deviations from Specifications.
- c. The "Original" shall be prepared on the bid forms included and made a part of the Bidding Documents, which shall be submitted with all applicable blanks in the bid forms properly filled in, and shall be manually signed in ink by a person or

persons duly authorized. The letter of authorization shall be indicated by written power-of-attorney accompanying the bid.

All pages of the bid, except for unamended printed literature, shall be initialled by the person or persons signing the bid.

- d. The bid shall contain no interlineations, erasures or overwriting except as necessary to correct errors made by the Bidder, in which case such corrections shall be initialled by the person or persons signing the bid.
- e. Modification by letter or *by letter submitted electronically or by electronic mail (E-mail)* to bids already submitted will be considered if received prior to the time fixed for the receipt of bids. Confirmation by letter of any modification *evidenced* by post mark or by *letter submitted electronically or by electronic mail (E-mail)* should be sent to EGAT not later than the deadline for submission of Bids.
- f. No Bidder will be permitted to alter his bid after the bids have been opened, but clarifications not changing the substance of the bid therein may be accepted.
- g. Bidder may quote for any schedule or all schedules as called for, but shall quote for all items of the schedule(s) proposed. Consideration will be made as stipulated in Article B-12. Evaluation and Comparison of Bids.
- h. Any price discount to be offered shall be clearly stated in the Discount Form accompanied with the Bid to be submitted on the bid opening date specified herein.

B-2. Bid Prices

Currency

Bid prices as shown in Article C-1. Price Schedule shall be firm, not subject to adjustment and payable in the currencies as follows :

- a. The bid price shall be quoted in Thai baht, US dollar, euro, Japanese yen, renminbi (Chinese yuan), or in the Bidder's or Manufacturer's home currency only if his currency trading is prevailed at the time of bidding in any international market other than in Bidder's or Manufacturer's home country.

If the currencies quoted by the Bidder do not conform to the requirement set forth herein, EGAT reserves the right to convert the bid price to US dollars by using the exchange rate on the Bloomberg screen which is announced at 10.00 a.m. (Bangkok Time) on the bid opening date. Such converted bid price in US dollars shall be treated as the Bidder's proposed bid price. In such case the Contract Price for such portion under the Contract shall be made in US dollars.

Subject to paragraph a. above, in case the Bidder expects to incur a portion of its expenditures in the performance of the Contract in more than one currency and wishes to be paid accordingly, the bid price shall be expressed in different currencies and the respective amount in each currency together making up the total price.

- b. Local expenditures shall be quoted in Thai Baht.
- c. Payments will be made in the currency or currencies in which the bid prices have been stated.

Source of Supply and Service

- a. Prices for Equipment manufactured in Thailand shall be firm ex-works prices and quoted in Thai Baht. Any import duty and taxes (value added tax included) assessed by the Government of Thailand at the port of entry on imported raw materials or components shall be paid by the Contractor and included in these ex-works prices.
- b. Prices for Equipment manufactured outside Thailand (imported Equipment) shall be firm, stated both on FOB Port of Shipment/Vessel and CFR Thai Port basis, and quoted in currencies specified above. Any import duty, excise tax (if any) and value added tax to be assessed by the Government of Thailand at the port of entry shall not be included in the quoted bid prices.

Prices for the following Equipment manufactured outside Thailand which was imported before the bid opening date shall be firm ex-works and quoted in Thai baht, provided that the Bidder shall submit any document(s) evidencing the importation date of such Equipment:

- ***Power Fuse***
- ***Stationary Battery and Battery Charger***
- ***Insulator for substation***
- ***Cable Termination***
- ***Compression Connector and Miscellaneous Hardware***
- ***Bus Fittings***
- ***Grounding Material***
- ***Substation Miscellaneous***

- c. Prices for services including cost of installation supervisor (if any) shall be firm.
- d. All expenses incurred for the Work specified in Article F-1. Scope of Work shall be included in the quoted Bid Prices.

Price Schedule

The Bidder shall enter a unit price, an amount, or a lump sum price, as required, for every item listed in the price schedule. If the unit price as entered does not conform to the amount entered for the same item, the unit price shall govern. If the sum of the amount entered for individual items does not conform to the total amount entered for these amounts under total bid prices, then the sum of the amount entered for the individual items shall govern.

Where quantity and total price only are required, the unit price shall be taken as the stated total price divided by the quantity specified.

Except for foreign supply, VAT at the prevailing rate shall be filled automatically in the Summary of Bid Price of the price schedule in the Excel file. However, the Contract Price shall include VAT only for the portion of Work which is subject to VAT.

B-3. Bid Security

The original of the bid submitted shall be accompanied with a bid security in the form of a cash deposit, or a cashier cheque issued by a local bank, or a bank guarantee or a letter of guarantee issued only by a local bank or an acceptable financial institution in Thailand, or by a foreign bank counter-guaranteed by a local bank as primary obligor. In case of a cash deposit or a cashier cheque, only Thai baht can be made.

The bid security shall be in a form as per specimen attached or in any other form with essential content in accordance with the specimen, and made payable to EGAT in the amount as specified in Data Sheet. Any bid not being accompanied with bid security shall be rejected. The bid security shall remain in force up to and including ninety (90) Days after the expiry date of the bid validity.

The bid security shall be forfeited in favor of EGAT if :

- a. The Bidder withdraws his bid after the bid is opened; or
- b. The successful Bidder fails for any reason to execute the Contract or to furnish a performance security.

The Bidder may, upon EGAT's request to extend the bid security when it has expired, refuse to do so without forfeiting the bid security. A Bidder granting the request will be neither required nor permitted to modify his bids.

The bid security of unsuccessful Bidder(s) will be returned as decided by EGAT or within thirty (30) Days following EGAT's acceptance of the successful Bidder.

The bid security of the successful Bidder will be returned upon execution of the Contract and after the performance security furnished has been accepted by EGAT.

B-4. Validity of Bids

The validity of the bid shall be as specified in Data Sheet.

In the event EGAT requires the validity period to be extended, EGAT may in writing or by *letter submitted electronically or by electronic mail (E-mail)* so notify the Bidders at least fourteen (14) Days prior to the expiry date of the validity period, in which event any Bidder not agreeing to such request for extension may withdraw his bid by so advising EGAT in writing or by *letter submitted electronically or by electronic mail (E-mail)* prior to the expiry date of the original validity period. If the advice of withdrawal shall not have been received by EGAT prior to the said date, the extension shall be deemed to have been accepted by the Bidder, and the Bidder shall be required to extend the effective period of the bid security accordingly.

B-5. Delivery of Bids

Where bids are submitted by mail, the hour and date of receipt of the bid will be taken as that certified by EGAT. For all bids delivered directly, a receipt will be furnished to the Bidder indicating the place, hour, and date of delivery. Late bids will be returned unopened.

B-6. Withdrawal of Bids

Bids may be withdrawn only on written requests which are received by EGAT prior to the time fixed for the receipt of the bids. Negligence on the part of the Bidder in preparing his bid confers no right for the withdrawal of the bid after it has been opened. Whenever a bid has been withdrawn, it will be returned unopened to the Bidder.

B-7. Interpretation of Bidding Documents before Bid Opening

If a prospective Bidder is in doubt about the true meaning of any part of the Bidding Documents, the Bidder may submit to EGAT a written request for a reply or an interpretation; provided that sufficient time is allowed for a reply to reach the prospective Bidder prior to the date specified for bid opening. An interpretation will be given in the form of a Supplemental Notice furnished to all prospective Bidders. Receipt of all Supplemental Notices shall be acknowledged by each prospective Bidder on the Proposal. Oral interpretation of the Bidding Documents will not be binding.

B-8. Information to be Submitted with Bid

Each Bidder shall submit with his bid the following documents, data and information in English language in addition to any other information called for elsewhere in the Bidding Documents in order to enable EGAT to fully evaluate the Proposal of the Bidder :

- a. Name of manufacturer and country of origin and type or model of Equipment he proposes to furnish.
- b. Data, drawings, catalogue and descriptive materials which will show equipment arrangement, general dimensions, principles of operation, extent of factory assembly, and the materials from which parts are made.
- c. Sufficient references describing the technical experience of the manufacturers, including lists of the Equipment supplied and installed overseas. If possible, certificates issued by the user and/or consulting engineers supporting the said work and record of commercial operation in good condition should also be submitted.
- d. Copies of Auditor's certified balance sheet of the Bidder for the past three (3) consecutive years.
- e. In case the local manufactured Equipment is proposed, the sufficient documentary evidence, if any, showing that the manufacturers have been acknowledged for producing standard product by the Thai Industrial Standard Institute (TISI), Ministry of Industry, or registered with TISI, or ISO 9000 certified by the National Accreditation Council of Thailand (NAC) or obtained the privilege from the Board of Investment or accepted by EGAT for manufacture of such Equipment, is required to be submitted with the Bid.
- f. Sufficient evidence documents clearly demonstrating that a firm/company who changes its name, merges with, or acquires other company/companies, or forms a new company by merging its business unit with those of other companies, and the experience records of the new company clearly demonstrating that it has sufficient evidence of running the business as before.
- g. A statement of proposed minor deviations from the Specifications along with complete specifications and all necessary descriptive literature for any proposed alternative Equipment or procedure, as required under Article B-9. Deviations from Specifications.
- h. Where Proposal Data Forms are provided, the Bidder shall enter all information as directed.

- i. Where the Specifications provide for submission of a sample or samples, the Bidder shall submit same together with his bid.
- j. Joint Venture/Consortium Agreement with a statement that each member of a joint venture/consortium will be jointly and severally responsible and liable for the complete execution of the work (in case the Bidder is a joint venture or consortium).
- k. Confirmation Form of not being a Jointly Interested Bidder with other Bidders and not being a person who undertakes any actions as an Obstruction of Fair Price Competition, and Registration/Non-registration with the Revenue Department as a VAT registrant.

If the Bidder has registered as a VAT registrant, he shall submit EGAT an evidence of VAT registration. On the contrary, if the Bidder is not registered as a VAT registrant, he shall inform EGAT whether he will register as a VAT registrant or not.

In case the Bidder is a consortium, each member of the consortium shall fill in the Confirmation Form provided for consortium Bidders.

- l. Filled-in Documentary List and documents required according to Additional Regulation.
- m. A statement indicating that the parent manufacturer shall certify and be responsible for the design, production process and quality control. This information is required only for the Equipment specified in Data Sheet.

Should the Bidder fail to submit any of the document described above and neglect to submit the same to EGAT within the time as specified by EGAT, such failure shall be sufficient reason for rejection of his bid.

Verbal statements made by the Bidder at any time regarding quality, quantity, or arrangement of Equipment will not be considered.

If alternative Equipment is indicated in the bid, it shall be understood that EGAT will have the option of selecting any one of the alternates so indicated and such selection shall not be a cause for extra compensation or extension of time.

In case the Bidder proposes alternative Equipment, with the condition to supply any one of the alternates so indicated at his option, such bid will be considered conditional and may be considered sufficient reasons for rejection.

B-9. Deviations from Specifications

Unless otherwise provided in the Specifications, the quality of Equipment and workmanship shall comply in all respects with the Standards required under the bidding documents.

If the Bidder proposes any minor deviations from the specifications, he shall submit a statement of each proposed deviation referenced to the particular Article of these specifications, details on the design drawings or article, paragraph and section of referenced standards or specifications. Full details of all minor deviations together with confirmation shall be submitted with the bid in a form provided in Section C. The Bidder shall submit, with his bid, copies of the standards or specifications proposed for his deviations. In case there is no statement in the form provided in Section C in the Bidder's proposal on the proposed deviations, the bid shall be regarded by EGAT as conforming in all respects to the terms and conditions and Specifications as stated in the bidding documents at no additional cost to the bid price.

Notwithstanding the foregoing, it is at EGAT's sole discretion in determining whether any of such proposed deviations is acceptable and in determining whether it is minor or major deviation.

B-10. Rejection of Bids

EGAT reserves the right not to accept the lowest evaluated bid.

Bids shall be strictly based on the Specifications and terms and conditions in the Bidding Documents. Should any bid fail to comply with the terms and conditions stipulated in these Bidding Documents, especially those under Article pertaining to payment or be incomplete, conditional or obscure, or contain additions not called for, or irregularities of any kind, it will be liable to rejection.

EGAT also reserves the right to reject any or all bids submitted without giving reason or to reject the bid from any Bidder who fails to satisfy EGAT that the bid complies with the terms and conditions stipulated in these bidding documents without any non-compliance which is deemed substantial and advantageous over other Bidders.

B-11. Delivery Time

Delivery time required is indicated for each respective Price Schedule in the Proposal section of the Bidding Documents, and shall be carefully observed. However, no preference will be given in the bid evaluation for earlier delivery than the stipulated delivery period.

All bids specifying delivery time later than those indicated may be rejected.

B-12. Evaluation and Comparison of Bids

Bid prices pursuant to Article B-2. Bid Prices will be evaluated as follows :

1. The evaluation of bid prices shall be specified in Data Sheet.
2. Bid prices will be converted into Thai Baht at the selling exchange rates, published by the Bank of Thailand, www.bot.or.th between Baht and other currencies on the bid opening date.
3. The rate of import duty prevailed on the bid opening date will be used for the purpose of bid evaluation of CFR Thai Port Price.
4. The prices to be used for evaluation and comparison purpose shall be as follows :
 1. Ex-works price including VAT for the final sale direct to EGAT for locally manufactured Equipment
 2. CFR Thai Port of Equipment to be imported plus the calculated insurance premium of 0.072% of [CFR price+10% (CFR price)], import duty, excise tax (if any), value added tax to be assessed by the Thai Government at the port of entry for imported Equipment , and 0.6 % of CFR price for customs clearance

The rate of import duty to be used for price comparison shall be as follows:

- a) For Equipment consisting of separate components which are intended to contribute together as a functional unit and imported under partial import entry - using a normal single tariff rate published in the Customs Tariff Decree for such Equipment
- b) For other Equipment and spare parts
 - i) In case any imported Equipment and spare part is proposed from one (1) country of origin for the same item:
 - Country of Origin Under Free Trade Agreement (FTA) – using lower comparing rate between the FTA rate and the normal rate published in the Customs Tariff Decree;
 - Country of Origin Under Non FTA – using a normal rate published in the Customs Tariff Decree.
 - ii) In case any imported Equipment and spare part is proposed from different countries of origin for the same item, a normal rate published in the Customs Tariff Decree for such Equipment and spare part will be used for price comparison.

3. Cost of local transportation including VAT, if any
4. Cost of installation supervisor including VAT, if any
5. Guaranteed losses of Equipment, if any, at the rate as stipulated in the Proposal Data.

Price for optional items, if any, will not be taken into consideration; however, Bidders shall also quote the prices thereof as required.

B-13. Acceptance of Bids

EGAT will not be bound to accept the bid with the lowest indicated cost. EGAT reserves the right to accept the bid which in its judgement is the lowest evaluated bid. In making its selection, EGAT will take into consideration the conformity of the bid to the requirements of the Bidding Documents and Specifications, guaranteed delivery time, the suitability for the purpose intended and whenever applicable, compensating factors will be applied to deviation or departures from Specifications. EGAT will also take into consideration whether the Bidder's experience, organization, facilities and financial resources will assure the successful carrying out of the Work under the Contract within the time specified.

B-14. Appeal

Disqualified or unsuccessful Bidders who see that their disqualification or failure are due to EGAT's non-compliance with EGAT's procurement regulations may appeal to EGAT within fifteen (15) Days from the date of receipt or announcement, whichever comes first, of EGAT's final evaluation result. An appeal shall be made in writing and clearly state the cause of appeal and argument with referred facts or regulations and related documents. Appealing does not constitute a ground for suspending the ongoing procurement process unless EGAT's Governor agrees otherwise.

The Contract or Purchase Order shall not be executed until the period of appeal has ended and there is no appeal. In the event there is an appeal during such period, the Contract or Purchase Order shall not be executed unless EGAT's Governor concurs.

Decision of EGAT's Governor is final and conclusive.

B-15. Award of Contract

The Contract will be awarded as soon as practicable after opening of the bids, to the Bidder with the lowest evaluated bid. EGAT reserves the right to award the Contract on the basis of standards and specifications as proposed by the Bidder, if in the opinion of EGAT, they are considered acceptable.

At the time of execution of the Contract, the successful Bidder shall furnish the performance security in accordance with the conditions of Contract in the specimen of performance security provided in the bidding documents.

Failure to comply with the condition as expressed in the specimen of performance security will lead to withdrawal of award and cancellation of Contract, and in this respect EGAT reserves the right to award the Contract to the Bidder with the next lowest evaluated substantially responsive bid and the Bidder who defaults shall have his bid security forfeited in favor of EGAT.

After EGAT notifies the successful Bidder that his bid has been accepted, EGAT will send the Bidder the Contract Documents incorporating all agreements between the parties not later than ninety (90) Days after confirmation of Letter of Award of Contract.

Promptly but not later than fifteen (15) Days after receipt of the Contract, the successful Bidder shall sign and date the Contract and return it to EGAT.

B-16. Bidder's Responsibility

The Bidder shall be deemed to have carefully examined all of the terms, conditions and Specifications of this Invitation to Bid, and also to have fully informed himself as to all conditions, local or otherwise, affecting the carrying out of the Work of the Contract, and to have formulated an estimate of the facilities available and needed.

The Bidder shall also be liable to any rules and regulations as well as Acts enforced in the Kingdom of Thailand. Failure to do so will be at the Bidder's risk.

B-17. Supplemental Notices

Supplemental Notices to the Bidding Documents may be issued prior to the date of opening of bids to clarify the Bidding Documents or to reflect modifications in the design or Contract terms. Each supplemental notice issued will be distributed to each person or organization to whom the Bidding Documents have been issued. The recipient shall acknowledge receipt of each supplemental notice by signing and returning in a reasonable time the receipt form distributed with the supplemental notice. All supplemental notices issued shall become a part of the Contract Documents.

B-18. Cost of Bidding

Bidders will not be reimbursed for any expenses they may incur in preparing and submitting their bids.

B-19. Cancellation of Bid

EGAT reserves the right not to accept any quantity or item or schedule or package, or to cancel the bid without purchasing any item. Bidders shall not be entitled to claim EGAT for any losses and/or damages in this connection. EGAT also reserves the right to cancel the bid should there be any reasonable grounds that bidder is not in good faith in submitting bid such as submitting false documents.

In case of bid cancellation, EGAT will not be responsible for any losses and/or damages and will not refund payment of Bidding Documents.

DRAFT

SPECIMEN OF BID SECURITY

Whereas.....(hereinafter called "the Bidder") has submitted his bid dated.....for.....(hereinafter called "the Bid") under Invitation to Bid No.....KNOW ALL MEN by these presents that WE.....of.....having our registered office at.....(hereinafter called "the Guarantor") are bound unto Electricity Generating Authority of Thailand (hereinafter called "EGAT") in the sum of..... (in words :) for which payment well and truly to be made to EGAT, the Guarantor binds itself, its successors and assigns by these presents. Sealed with the Common Seal of the said Bank this.....(date).....day of.....(month).....,(year).....

THE CONDITIONS of this obligation are :

1. If the Bidder withdraws his bid during the period of bid validity specified in the Bidding Documents; or
2. If the Bidder, having been notified of the acceptance of his bid by EGAT during the period of bid validity;
 - (a) fails or refuses to execute the Contract, if required; or
 - (b) fails or refuses to furnish the Performance Security, in accordance with the Instructions to Bidders;

We, the Guarantor, unconditionally undertake to pay to EGAT as the primary obligor, up to the above amount upon receipt of its first written demand, without EGAT having to substantiate its demand.

This guarantee will remain in force up to and including ninety (90) Days after the expiry date of the bid validity.

(Signature of the Bank)

DRAFT

**SECTION C
PROPOSAL**

INVITATION TO BID NO. SPSR-RX-01
PROPOSAL
FOR
SUPPLY OF 500 kV 110 MVAR SHUNT REACTOR
SUPPLY AND INSTALLATION OF 500 kV
110 MVAR SHUNT REACTOR

C-1. Price Schedule

The undersigned Bidder, having carefully examined the Bidding Documents, hereby offers and proposes to perform the services and to furnish the Equipment on the basis of FOB Port of Shipment/Vessel or CFR Thai Port as specified in the Delivery Schedule and Distribution List for foreign supply or Ex-works delivery for local supply, in accordance with all provisions and conditions as described herein, all for the prices stated in the Schedule(s) attached.

Note : 1. Article C-1. Price Schedule

For imported Equipment, EGAT reserves the right to award the Contract on either FOB Port of Shipment/Vessel or CFR Thai Port basis.

2. Article E-12. Performance Security

The performance security required under Article E-12. Performance Security shall be ten (10) per cent, round up to the nearest whole number, of the Contract Price. Cost for furnishing the performance security shall be spread over the items proposed.

C-2. Penalty for Equipment Not Meeting Guaranteed Characteristics

The losses of Equipment shall be evaluated with the same rate as stipulated in the Proposal Data.

If the Equipment proposed fails to meet the guaranteed characteristics or the price of the measured losses is higher than the price of the guaranteed losses, the Contract price of Equipment shall be reduced by the different amount of the comparison between the price of the measured losses and the price of the guaranteed losses.

C-3. Guaranteed Delivery Time

Delivery Time of Equipment is required as indicated in the Delivery Schedule and Distribution List attached. The undersigned Bidder guarantees to make and to complete the delivery of Equipment proposed as required by EGAT.

Whenever the Equipment in any item are sub-itemized, the Contractor shall endeavor not to make partial shipment/delivery by sub-items.

In case of failure on the part of the Contractor to comply with the provision of the above paragraph, it is hereby understood that the Equipment in such particular items shall be deemed undelivered unless and until each all sub-items have been shipped/delivered.

C-4. Drawing and Document Submission Schedule

Drawing and Document Submission Schedule is required as indicated in Article F-11. Drawings and Documents to be Furnished by Contractor. The undersigned Bidder guarantees to submit all drawings and documents as required by EGAT.

C-5. Estimate of Deliveries

The estimated number of individual shipment/delivery, shipping point or points, estimated delivery date and estimated shipping weights and volumes for each individual shipping will be as follows :

<u>Number of Shipments</u>	<u>Item No.</u>	<u>Shipping Point</u>	<u>Estimated Delivery Date from Shipping Point</u>	<u>Total Weight kg.</u>	<u>Total Volume Cu.m.</u>
-----	-----	-----	-----	-----	-----
-----	-----	-----	-----	-----	-----
-----	-----	-----	-----	-----	-----
-----	-----	-----	-----	-----	-----

C-6. Bid Security

Bid security in the amount of _____,
(in words)
_____ has been deposited with EGAT.
(number)

C-7. Supplemental Notices

The undersigned Bidder certifies that the following Supplemental Notices have been received for the Contract Documents :

Proposal Submission Date _____ Day of _____ A.D. _____

Firm's Name _____

By _____

Title _____

Firm's Address _____

Witness

DRAFT

PART 1: PRICE PROPOSAL

PART 1 : PRICE PROPOSAL

PRICE QUOTATION INSTRUCTIONS

This part of the Bidding Document comprises :

1. Summary of Bid Prices
2. Price Schedules

Cost of Supply of Equipment comprises Foreign Portion and Local Portion. For Foreign Portion, Bidder is allowed to quote price in only four (4) different currencies. For Local Portion, default currency is Baht (THB).

Bidder shall fill in the price schedules in the Excel file(s), item by item. Then, the total prices for each schedule and Summary of Bid Prices will be automatically calculated.

Filling-in the data shall be in accordance with the following instructions :

1. Bidder shall fill in all data required in blue cells of the price schedules - Currency and Unit Price.
2. For local portion, the default is THB.
3. For foreign portion, Bidder shall fill a currency code in a column "Currency".

Remarks: Price Schedules are created in Microsoft Office Excel 2007.

INVITATION TO BID NO. SPSR-RX-01
SUMMARY OF BID PRICE
SUPPLY OF 500 KV 110 MVAR SHUNT REACTOR
SUPPLY AND INSTALLATION OF 500 KV 110 MVAR SHUNT REACTOR

No.	Description	Currency	Supply of Equipment	Supply of Equipment	Foreign Currency (excluding VAT)	Local Currency (excluding VAT) Baht
			Foreign Supply	Local Supply		
			CFR Thai Port	Ex-works Price (excluding VAT) Baht		
			Amount	Amount	Amount	Amount
1	Schedule 1 : 500 kV Shunt Reactor					
BID PRICE				Baht		Baht
VAT				Baht		Baht
SUMMARY OF BID PRICE				Baht		Baht

INVITATION TO BID NO. SPSR-RX-01
Schedule 1 : 500 kV Shunt Reactor
SUPPLY OF 500 KV 110 MVAR SHUNT REACTOR
SUPPLY AND INSTALLATION OF 500 KV 110 MVAR SHUNT REACTOR

Item No.	Description	Qty.	Unit	Currency	Supply of Equipment				Supply of Equipment		Foreign Currency (excluding VAT)	Local Currency (excluding VAT) Baht		
					Foreign Supply				Local Supply				Amount	Amount
					FOB Vessel	Cost of Transportation to Thai Port	CFR Thai Port		Ex-works Price (excluding VAT) Baht					
					Unit Price	Unit Price	Unit Price	Amount	Unit Price	Amount				
1-1	110 Mvar, 525 kV, three-phase shunt reactor complete with insulating oil and accessories as per Ratings and Features RF RX951A	1									XXXXX	XXXXX		
1-2	Cost of installation supervisor for Item No. 1-1		Man-day		XXXXX	XXXXX	XXXXX	XXXXX	XXXXX	XXXXX				
Total Price for Schedule 1												Baht		

INVITATION TO BID NO. SPSR-RX-01
Breakdown Price for Item No. 1-1
SUPPLY OF 500 KV 110 MVAR SHUNT REACTOR
SUPPLY AND INSTALLATION OF 500 KV 110 MVAR SHUNT REACTOR

Item No.	Description	Currency	Supply of Equipment				Supply of Equipment	
			Foreign Supply				Local Supply	
			FOB Vessel	Cost of Transportation to Thai Port	CFR Thai Port		Ex-works Price (excluding VAT) Baht	
			Unit Price	Unit Price	Unit Price	Amount	Unit Price	Amount
1	Unit price of 110 Mvar, 525 kV, three-phase shunt reactor complete with accessories as per Ratings and Features RF RX951A							
2	Price of Insulating Oil for using in one (1) unit of reactor under Item No. 1							

INVITATION TO BID NO. SPSR-RX-01
Service of Installation Supervisor (Schedule 1)
SUPPLY OF 500 KV 110 MVAR SHUNT REACTOR
SUPPLY AND INSTALLATION OF 500 KV 110 MVAR SHUNT REACTOR

Item No.	Description	Qty.	Unit	Currency	Foreign Currency (excluding VAT)		Local Currency (excluding VAT) Baht	
					Unit Price	Amount	Unit Price	Amount
1-2	Cost of installation supervisor for Item No. 1-1		Man-Day					

Note:

1. The quoted total man-days for installation supervisor shall be the required number of days for complete installation, erection, field test and commissioning of all equipment as specified.
2. In addition to the quoted total man-days above, EGAT will also pay the following :
 - a. Travelling time from and to Supervisor's home office as well as travelling time from and to the installation site including ten (10) working days of operation, if any, which will be at the same rate as the cost quoted per man-day.
 - b. Airfares round trip economy class between the Supervisor 's home office and Bangkok by the most expeditious and direct route.
3. Local transportation from and to installation site will be provided by EGAT.
4. If the working man-days are less than the quoted total man-days, the payment shall be on the basis of actual man-days.
5. For man-days exceeding the quoted total amount, no payment shall be made by EGAT. Any such additional man-days approved by EGAT shall be paid on the quoted man-days rate.

DRAFT

PART 2: PROPOSAL DATA

SHUNT REACTOR

FORM PD 731
Jan. 2026

PROPOSAL DATA

PROCUREMENT REFERENCE

SCHEDULE NO.

BIDDER

ITEM NO.

PART A All Bidders shall meet the following requirements; failure to so comply shall constitute sufficient ground for rejection. (Strictly requirement)

- a. Manufacturer / Country
- b. Type / Type of Core
- c. No. of Phase (Single or Three-phase)
- d. Applied Standards
- e. Type of Cooling
- f. Rated Power MVAR
- g. Rated Frequency / Rated Continuous Current Hz A
- h. Winding Voltage Rating
 - Highest Voltage (High Voltage / Neutral) kV
 - Rated Voltage (High Voltage / Neutral) kV
 - Lightning Impulse Withstand Voltage (High Voltage / Neutral) kV
 - Switching Impulse Withstand Voltage (High Voltage) kV
- i. Bushing Voltage Rating
 - Highest Voltage (High Voltage / Neutral) kV
 - Rated Voltage (High Voltage / Neutral) kV
 - Lightning Impulse Withstand Voltage (High Voltage / Neutral) kV
 - Switching Impulse Withstand Voltage, Wet (High Voltage) kV
- j. Knee Point of Excitation Curve
(% of Rated Voltage) kV
- k. Over Excitation
 - At 105 / 125 / 140 % Rated Voltage (50 Hz) s
 - At 100 % Rated Voltage (48 Hz) s
 - Overvoltage for 10 s (50 Hz) kV
- l. Audible Noise Level dB(A)
- m. Positive Sequence Reactance / Tolerance ohms %
- n. Temperature Rise at 105 % Rated Voltage
 - Average Winding / Hot-spot Winding °C
 - Top Insulating Liquid °C
- o. Shipping Weight kg
- p. Shipping Dimension

Width	Length	Height
<input type="text"/>	<input type="text"/>	<input type="text"/>

 m × m × m

Guaranteed Characteristics

- Losses at Rated Voltage and Rated Frequency at 80 °C kW

Important Notice

- 1) The guaranteed characteristics of loss shall be evaluated and included in the bid price for cost evaluation with the rate of 420,000 Baht for each kW or part thereof of the guaranteed loss.

If the reactors fail to meet the guaranteed characteristics herein indicated, the price of reactors shall be reduced in accordance with the condition specified in Article : Penalty for Equipment not Meeting Guaranteed Characteristics.

Remark

SHUNT REACTOR

FORM PD 731
Jan. 2026

PROPOSAL DATA

PROCUREMENT REFERENCE	SPSR-RX-01	SCHEDULE NO.	
BIDDER		ITEM NO.	

PART B All Bidders should preferably meet the following technical requirements; failure to so comply may constitute sufficient ground for rejection.

a. Partial Discharge Value	<input type="text"/>	pC	at	<input type="text"/>	kV
b. Third Harmonic Current (% of Fundamental)	<input type="text"/>				
c. Insulating Material					
- Winding Insulation Paper					
- Manufacturer/Country	<input type="text"/>				
- Temp. Class	<input type="text"/>				
- Pressboard and Other Insulating Material					
- Manufacturer/Country	<input type="text"/>				
- Temp. Class	<input type="text"/>				
d. Winding					
- Conductor Supplier Name / Country	<input type="text"/>	<input type="text"/>			
- Winding Type (Disk, Helical, Layer, etc.)	<input type="text"/>				
- Conductor Type (Rectangular, CTC : Continuous Transposed Cable, Bonded CTC, etc.)	<input type="text"/>				
- Proof Stress with Permanent Elongation of 0.2% ($\sigma_{0.2}$) of Copper	<input type="text"/>				
	kg/cm ²				
- Final Clamping Force of All Windings After Core and Coils Assembly	<input type="text"/>				
	kg				
e. Core (Main Leg / Return Leg)					
- Supplier Name / Country	<input type="text"/>	<input type="text"/>			
- Material / Grade (ZDKH, M2H, M4, etc.)	<input type="text"/>	<input type="text"/>			
- Numbers of Limb or Leg	<input type="text"/>	<input type="text"/>			
- Flux Density at Rated Voltage	<input type="text"/>	<input type="text"/>	Tesla		
- Core Diameter (Cross Section W×L, if rectangular)	<input type="text"/>	<input type="text"/>	mm		
- Core Sheet Thickness	<input type="text"/>	<input type="text"/>	mm		
- Loss at Rated Voltage, 50 Hz	<input type="text"/>	<input type="text"/>	W/kg		
- Clamping Method					
- Leg	<input type="text"/>	<input type="text"/>			
- Yoke	<input type="text"/>	<input type="text"/>			
f. High Voltage Bushing					
- Manufacturer / Country	<input type="text"/>	<input type="text"/>			
- Model No.	<input type="text"/>				
- Housing					
- Type	<input type="checkbox"/>	Porcelain	<input type="checkbox"/>	Composite	
	<input type="checkbox"/>	Condenser	<input type="checkbox"/>	Draw Lead	
	<input type="checkbox"/>	Solid	<input type="checkbox"/>	Fixed Conductor	
	<input type="checkbox"/>	Other	<input type="text"/>		
- Power Freq. Withstand (Dry / Wet)	<input type="text"/>	<input type="text"/>	kV		
- BIL	<input type="text"/>				
	kV				
- Rated Current	<input type="text"/>				
	A				
- Creepage Distance	<input type="text"/>				
	mm				

Remark

SHUNT REACTOR

FORM PD 731
Jan. 2026

PROPOSAL DATA

PROCUREMENT REFERENCE

SCHEDULE NO.

BIDDER

ITEM NO.

- g. Neutral Bushing
 - Manufacturer / Country
 - Model No.
 - Housing
 - Porcelain Composite
 - Condenser Draw Lead
 - Solid Fixed Conductor
 - Other
 - Power Freq. Withstand (Dry / Wet) kV
 - BIL kV
 - Rated Current A
 - Creepage Distance mm
- h. Bushing Current Transformer (BCT)
 - Manufacturer / Country
 - As Required Yes No
- i. Radiator Manufacturer / Country
- j. Rubber Bag Manufacturer / Country
- k. Insulating Oil
 - Type Uninhibited Inhibited
 - Manufacturer / Country
 - Manufacturer Type (Generic Name)
 - Applied Standard
- l. Tank
 - Cover: Welded Type Confirm
 - Base: Structural Steel Skid Base Confirm
- m. Weight
 - Core kg
 - Coils kg
 - Insulating Material (Pressboard and Paper) kg
 - Tank and Fittings kg
 - Quantity of Oil Furnished kg Litre
 - Total Weight With Oil kg
- n. Overall Dimension

Width	Length	Height	
<input type="text"/>	<input type="text"/>	<input type="text"/>	m × m × m

Remark

PART 3: DELIVERY SCHEDULE AND DISTRIBUTION LIST

DRAFT

**SECTION D
CONTRACT**

CONTRACT

SUPPLY OF 500 kV 110 MVAR SHUNT REACTOR

**SUPPLY AND INSTALLATION OF 500 kV
110 MVAR SHUNT REACTOR**

No. _____

This Contract is executed and delivered this _____ day of _____,
B.E. _____ (A.D. _____), between

ELECTRICITY GENERATING AUTHORITY OF THAILAND

represented by _____ of said Authority, hereinafter called "EGAT", and

(Contractor)

represented by _____, age _____ years, nationality _____, hereinafter called
the "Contractor".

EGAT and the Contractor mutually agree as follows :

D-1. Contract Documents

The following documents attached to this Contract are incorporated and made a part of this
Contract, as though fully written out and set forth herein :

Data Sheet

- A. Invitation to Bid
- B. Instructions to Bidders
- C. Contract Price, Delivery Time of Equipment and Proposal Data
- D. Contract
- E. General Conditions
- F. Special Conditions
- G. Ratings and Features
- H. Bill of Materials (None)
- I. Specifications
- J. Drawings (None)
- K. Supplemental Notices

L. Attachments :

M. Changes :

All of the foregoing documents are referred to herein as the Contract Documents. They are also incorporated into this Contract and made a part hereof all codes, designations, standards, standard specifications and similar Equipment which are referred to in the Specifications and Special Conditions.

D-2. Acceptance of Proposal

EGAT has accepted the proposal of the Contractor for furnishing the Equipment in conformity and in accordance with and subject to all the terms and conditions of these Contract Documents.

D-3. Agreement

The Contractor agrees to sell and EGAT agrees to buy the Equipment as described in these Contract Documents.

D-4. Obligation of Contractor

The Contractor agrees to perform well and faithfully all of the services and to furnish all of the Equipment described in these Contract Documents, and to supply and provide all Equipment, labor and other things requisite for or incidental to the said Work.

D-5. Obligation of EGAT

EGAT agrees, subject to the terms and conditions of these Contract Documents, to pay to the Contractor the amount shown, and at the rates and times and in the manner set forth in these Contract Documents.

D-6. Mutual Obligations

EGAT and the Contractor mutually agree to perform, fulfill, abide by, and submit to any and all of the provisions and requirements and all matters and things contained or expressed in, or reasonably to be inferred from these Contract Documents.

D-7. Deposit of Performance Security

The Contractor agrees to deposit with EGAT an acceptable performance security in accordance with the Contract Documents.

D-8. Assignment

The Contract or any part thereof shall not be assigned or pledged without the written consent of EGAT, nor shall the Contractor assign or pledge any money due, or to become due, to him hereunder, without the prior written consent of EGAT.

D-9. Notices

All notices called for by the terms of this Contract shall be effective only at the time of receipt thereof and only when received by the parties to whom they are addressed at the following addresses :

EGAT : Governor
Electricity Generating Authority of Thailand
Bangkruai, Nonthaburi 11130
Thailand

Contractor : _____

All notices called for by the terms of this Contract shall be in the form of registered letters or *letters submitted electronically or electronic mails (E-mails)* in the English language.

DRAFT

SECTION E
GENERAL CONDITIONS

GENERAL CONDITIONS

E-1. Definitions

Whenever the following terms are used in the Contract Documents, they will have the following meanings :

- EGAT : The Electricity Generating Authority of Thailand, having its Head Office at Nonthaburi, Thailand, and its authorized representative or representatives
- Engineer : Firm or company assigned by EGAT to provide engineering, consulting or construction management services in support of EGAT
- Bidder : Any person or firm or company or joint venture or consortium of firms submitting bid to EGAT for furnishing the services and Equipment described in the Contract Documents, in response to this Invitation to Bid
- Contractor : Any person or firm or company or joint venture or consortium of firms including appointed representatives, successors and assignees thereof, whose bid has been accepted by EGAT for furnishing of the services and Equipment described in the Contract Documents
- Subcontractor : Any person or firm or company (other than the Contractor) to whom any part of the Contract has been sublet, with the consent of EGAT, by the Contractor
- Contract : The agreement between EGAT and the Contractor, and all Appendices and Schedules thereto including Invitation to Bid, Instructions to Bidders, Proposal, General Conditions, Special Conditions, Specifications, Ratings and Features, Drawings, Supplemental Notices and any other documents referred to in, or connected with the Contract, eventhough the said documents are issued after execution of the Contract
- Contract Price : The sum specified in Section C which is inclusive of VAT (if any) subject to such additions thereto or deductions therefrom as may be made under the provisions hereinafter contained

Equipment	:	Machinery, apparatus, materials, goods, including accessories and spare parts to be supplied under the Contract and specifically described in the Specifications
Work	:	All the work to be done by the Contractor for design manufacture, shop test, transportation, and delivery of the Equipment ex-works, FOB Port of Shipment/Vessel or CFR Thai Port or at EGAT's store/site as agreed, including, if required, supervision for installation at site and supervision for field tests of the Equipment under the Contract
Thai Port	:	Commercial ports in Thailand including but not limited to Bangkok Port, Laem Chabang Port, Sriracha Harbour Port, Siam Seaport, Maptaphut Port, Songkhla Port, Phuket Harbour Port or Suvarnabhumi Airport, as the case may be
Bangkok Port	:	Bangkok Wharf (Klong Toey Port) and all other commercial ports in Bangkok Metropolitan area
Supervisor (if required)	:	Contractor's employee assigned as installation supervisor including assistant supervisor, to supervise and be responsible for the installation, erection, adjustment, field tests, and commissioning of the Equipment supplied under the Contract
Option (if any)	:	Equipment to be quoted by the Bidder which EGAT reserves the right to accept or omit in whole or in part
Year	:	Calendar year
Month	:	Calendar month
Day	:	Calendar day

E-2. Intent of Contract Documents

All of the Contract Documents are complementary, and what is called for by one shall be as binding as if called for by all. In the case of any discrepancy between any of the Contract Documents, or any defective description or ambiguity, the matter shall be promptly submitted to EGAT, which shall promptly make a determination in writing. Any adjustment by the Contractor without this determination shall be at the Contractor's own risk and expense. In all cases of discrepancy, defective description, or ambiguities, the interpretation given by EGAT shall be binding on the Contractor, subject to the provisions of Article E-31. Dispute Resolution, included in these General Conditions.

E-3. Applicable Law and Legal Jurisdiction

The applicable law of this Contract shall be the law in force in the Kingdom of Thailand. Should there be any ambiguity or discrepancy arising out of or in connection with the Contract Documents, the interpretation thereof shall be made in accordance with Thai laws. Any litigations between the parties that may arise out of or in connection with this Contract or the breach or termination thereof or the performance of work thereunder shall be submitted to the Court of Thailand for decision, except as may be otherwise specifically provided in these Contract documents.

E-4. Statutory Requirements

Throughout the continuance of the Contract, the Contractor shall conform to all laws of the Kingdom of Thailand, and to all regulations, by-laws, ordinances, or orders made thereunder, and to the lawful requirements of any public, municipal, or other authority, in any way affecting or applicable to the Contractor or its operations.

E-5. Patents and Copyrights

The Contractor shall indemnify and hold EGAT, its officers, agents, and employees harmless against and from liability of any nature or kind, including costs and expenses for or on account of any copyrighted or uncopyrighted composition, secret process, patented or unpatented invention, article, or appliance manufactured, delivered, or used in carrying out the Work under the Contract. All drawings and the information contained therein as well as the use of any process, material or Equipment developed in the course of carrying out the Work under the Contract shall become the property of EGAT where EGAT shall have the right to use any or all of them for any purpose either for present or future projects. For the avoidance of doubt, none of them will be used solely for any commercial benefit which is not related to EGAT work.

E-6. Subcontracts

The Contractor shall not assign or transfer the Contract or any part thereof or any benefit or interest therein or thereunder, any monies due or become due under this Contract to any other person or persons.

The Contractor shall not be allowed to subcontract the whole of the Work under this Contract. Subcontracting of any part of the Work shall be subject to the prior written consent of EGAT. Such consent, if given, shall not relieve the Contractor from full and entire responsibility under this Contract.

If the Contractor desires to subcontract any part or parts of the Work called for by the Contract, he shall notify EGAT in writing to that effect and shall state in such notice the nature and extent of the part or parts of the Work called for by the Contract proposed to be subcontracted and name of the person proposed as Subcontractor. Unless and until written approval is given by EGAT, approval for which shall not be unreasonably withheld, the Contractor shall not subcontract any part of the Work. All requirements specified in these Contract Documents shall be applicable to Subcontractors also.

No contractual relation shall exist between EGAT and the Subcontractors, and the Subcontractors are not to enjoy any privileges conferred on the Contractor by this Contract.

Any Work done by any Subcontractor who has not been approved by EGAT shall be subject to rejection or stoppage of Work by EGAT. In such case the Contractor cannot claim delay or request for time extension of the Contract completion date and/or make financial claim to EGAT.

E-7. Export Charges

All tariffs, duties and other taxes or charges levied by the country of origin of the Equipment shall be paid by the Contractor, and such expenses shall be included in the cost of the Equipment.

E-8. Import Duty and Taxes

EGAT will pay all costs of procuring the necessary permits and licenses for importation into Thailand, and will pay import duty and any taxes including value added tax imposed at the port of entry on the Equipment to be supplied by the Contractor and imported into Thailand for the Work under this Contract.

EGAT will not pay import duty and taxes on either the personal effects of the Contractor's employees, such as personal articles, household furnishings and appliances, and goods of any kind imported for the personal use of the Contractor's employees whether imported by an employee or by the Contractor, or in respect of food, tobacco, liquor and other commissary goods imported by the Contractor or by his employees.

EGAT will not pay import duty and taxes including value added tax on equipment, tools, instruments and machinery imported by the Contractor for purpose of carrying out the work under the Contract. All processes of importation shall be arranged by the Contractor.

Equipment, tools, instruments and machinery which are certified by the Contractor that they are required for installation, test and commissioning of the Work at the site and they are intended for re-exportation can be temporarily exempted from import duty and taxes including value added tax. All Equipment thereof shall be imported under the name of the Contractor and be in accordance with the rules and regulations of the Customs Department of the Kingdom of Thailand.

EGAT will assist the Contractor for such temporary exemption of import duty and taxes including value added tax by issuing a letter confirming such temporary import. Import duty and taxes including value added tax for the temporarily imported Equipment shall be paid by the Contractor to the Customs Department before re-exportation at the rate to be specified by the Customs Department at the time of importation for the whole period they have been imported into the Kingdom of Thailand. Temporary importation of the Equipment is subject to approval of the Customs Department and the deposit of a bond with the Customs Department in the amount to be notified by the Customs Department is required. All costs for submission of information and data if required by the Customs Department and the cost of provision of the bond shall be borne by the Contractor.

In view of numerous advantages, the ATA Carnet system or other systems may be arranged for shipment of the said temporarily imported equipment by the Contractor (if required). Any charge incurred and/or any liability shall be borne by the Contractor.

E-9. Value Added Tax

Pursuant to the Revenue Code of Thailand, EGAT shall be responsible and pay when due for the value added tax imposed on the supply of Equipment, including local transportation (if any) and/or on the provision of services under this Contract. EGAT shall in no case be responsible for the value added tax collectible on any payment made by the Contractor under any subcontract or under any other circumstances and the Contractor shall comply with the rules and regulations of the Revenue Code of Thailand.

In case there is any change on the rate of value added tax imposed by the Government of Thailand, the amount of value added tax comprised in the Contract Price shall be adjusted to reflect such change, provided that the price of the Work shall remain unchanged.

E-10. Income and Other Taxes

Income and other taxes assessed or collected by the Government of Thailand, or any subdivision thereof, or any municipality therein on the Contractor and his employees shall be under the responsibility and account of the Contractor.

In accordance with the Revenue Code of Thailand, should the payment under this Contract be subject to income tax and withholding tax of any kind is required to be withheld by EGAT, such withholding tax shall be deducted by EGAT from each payment and EGAT will be responsible to remit such withholding tax to the Revenue Department of Thailand on behalf of the Contractor. In case any payment being made through the letter of credit or being made directly from foreign source whereby the withholding tax cannot be deducted from payment, the Contractor is required to immediately inform EGAT once each such payment is made to the Contractor, and the withholding tax of which will be paid from EGAT's own fund to the Revenue Department in the same manner as aforesaid. Such withholding tax amount as advanced by EGAT on behalf of the Contractor shall be reimbursed by the Contractor to EGAT within the period of time fixed by EGAT.

In the case where the Contractor considers that the transaction under this Contract is exempted from income tax of Thailand (under any circumstance), the Contractor shall submit, together with his proposal(s), a statement detailing such exemption and the valid documentary evidence. Should EGAT rely on the statement so submitted, no deduction for withholding tax shall be made from payment. However, if the tax authority of Thailand determines that such exemption is not applicable, the Contractor shall then be responsible for the amount(s) equal to the withholding tax, plus the amount(s) of tax exceeding those of withholding tax, including the surcharge and/or penalties imposed on EGAT and the Contractor. The responsibility and liability of the Contractor as provided in the preceding sentence shall survive termination of the Contract.

If the Contractor fails to immediately inform EGAT of the payment as required under the second paragraph preventing EGAT from remitting the withholding tax to the Revenue Department within seven (7) Days from the end of the month in which such payment is made, or fails to pay and/or reimburse EGAT for any amount required under this Article within the period of time fixed by EGAT, such period not to be shorter than fifteen (15) Days from the date of EGAT's notice for payment, EGAT has the right to claim directly from the Contractor or claim from Performance Security or Maintenance Security, as the case may be, or deduct or setoff from any money due to the Contractor under this Contract

for the outstanding amount, surcharge and/or penalty (if any) together with interest at the rate of Minimum Overdraft Rate (MOR) plus two (2) per cent calculated from the due date up to the date the payment is made in full.

EGAT will proceed with the tax matters under the Contract by relying on the information and document submitted by the Contractor in relation to the Bidder's status and tax liability. If the Revenue Department of Thailand differently determines the status and tax liability, the Contractor shall be responsible and liable for any cost and expense, penalty and/or surcharge incurred and/or imposed on him and EGAT in relation thereto.

E-11. Fees and Duties

Any and all immigration fees, stamp duties, and other fees assessed or collected by the Government of Thailand, or by any subdivision thereof, or by any municipality therein, on this Contract, on the Contractor and/or his personnel shall be paid by the Contractor. Any taxes collectible under this Contract, other than those stipulated in this Contract, shall be at the responsibility and account of the Contractor.

The stamp duty for any service contract (Construction, Hire of Work, Consultancy Service, Transportation, Supervisor, etc.) with the Contract value of the service portion lower than baht 200,000.- is required to be affixed by the Contractor on the original copy and the counterpart of the Contract. In case the value of the service portion is baht 200,000.- and over, payment of such stamp duty by the Contractor shall be made in cash to the Revenue Department of Thailand or its authorized subdistrict offices. In either case, the stamp duty is required to be affixed or paid, as the case may be, within fifteen (15) Days after the date of Contract execution, otherwise the Contractor shall be liable to pay for any and all penalties imposed for the delay as required by law.

The Contract value of the service portion to be calculated for stamp duty under this provision shall be the price excluding value added tax.

For a foreign Contractor who has no representative in Thailand, EGAT will, upon receipt of written request from the Contractor, affix or pay for stamp duties from EGAT's own fund on behalf of the Contractor, the Contractor is therefore required to reimburse EGAT for such stamp duties plus any and all penalties imposed by law for delay, if such delay is due to Contractor's failure to make written request to EGAT as aforesaid within a reasonable period of time.

If the Contractor fails to reimburse EGAT for any and all amount as required under this Article within the period of time fixed by EGAT, such period not to be shorter than fifteen (15) Days from the date of EGAT's notice for payment, EGAT has the right to claim directly from the Contractor or claim from Performance Security or Maintenance Security,

as the case may be, or deduct or setoff from any and all money due to the Contractor under this Contract for the outstanding amount together with interest at the rate of Minimum Overdraft Rate (MOR) plus two (2) per cent calculated from the due date up to the date the payment is made in full.

E-12. Performance Security

The Contractor shall, at the time of execution of the Contract, deposit with EGAT a performance security for the due and proper performance of this Contract in the amount of ten (10) per cent, round up to the nearest whole number, of the total Contract Price. The performance security shall insure payment of any obligations, penalty, damages, liquidated damages, or expenses for which the Contractor may become liable to EGAT.

The amount of the performance security shall be adjusted or the Contractor may deposit a new performance security in the amount of ten (10) per cent, round up to the nearest whole number, of the additional Contract Price to cover the Contractor's obligation in case the Contract Price is increased due to change of the Work under the Article E-21. Changes and Extra or Omitted Work.

The performance security shall be in the form of a cash deposit, or a cashier cheque issued by a local bank, or a bank guarantee or letter of guarantee issued only by a local bank or an acceptable financial institution in Thailand, or by a foreign bank counter-guaranteed by a local bank and, made payable to EGAT in the same currency as that of the Contract. In case of a cash deposit or a cashier cheque, only Thai baht portion of the Contract Price can be made. EGAT may at any time, upon application by the Contractor, approve the substitution for any performance security held under this Article by other performance security on such terms and conditions as may be approved by EGAT. The Contractor shall bear the cost of the performance security.

The conditions of the guarantor's obligations in the performance security shall include, inter alia, the following :

- (1) The guarantor shall unconditionally guarantee, as primary obligor and not as surety merely, payment of any obligations, penalties, damages, liquidated damages, or expenses for which the Contractor may become liable to EGAT.
- (2) No extension of time, change in, addition to, or other modification of the terms of the Contract or Work to be performed thereunder, or of the specifications or other Contract Documents shall in anyway release the guarantor from any liability under the performance security, and the guarantor shall thereby waive notice of any such extension of time, change, addition or modification.

- (3) The performance security shall be valid and remain in full effect from the date of execution of the Contract until the issuance of the Acceptance Certificate by EGAT or the acceptance of Equipment deemed to be made by EGAT against submission of the Maintenance Security accepted by EGAT.

Unless and until an official receipt is issued in respect to a security deposit, EGAT will not recognize or accept any such deposit as fulfilling the requirements of this Article. Failure to deposit a performance security at the time specified above in this Article or such extended time as may be approved by EGAT shall be a breach of this Contract and EGAT is entitled to terminate the Contract or suspend any payment for Work performed until the performance security has been accepted by EGAT. EGAT shall not be liable for any losses, expenses and/or damages resulting from such payment suspension.

If any performance security furnished under this Article becomes unacceptable to EGAT, or if any guarantor fails to furnish reports as to guarantor's financial condition from time to time, as requested by EGAT, the Contractor shall promptly furnish such additional or alternative security as may be required by EGAT from time to time to protect the interests of EGAT up to an amount equal to the amount of the security.

In the event of any default or breach of this Contract by the Contractor, EGAT may convert into money any performance security which does not consist of money, and the proceeds shall be deemed to be a cash deposit under this Article. EGAT shall not be liable for any cost, expenses and/or loss incurred in connection with such conversion.

The performance security, in case of a bank guarantee, or letter of guarantee, shall be in conformity with the specimen acceptable to EGAT as shown herein at the end of these General Conditions.

E-13. Inspection and Tests

All Equipment furnished and all Work performed under this Contract shall be subject to inspection by EGAT or EGAT's authorized representatives at its option. While such Work is in progress to ascertain that the completed Work will comply in all respects with the standards and requirements set forth in the Contract Documents. Notwithstanding such inspection, the Contractor will be responsible for the acceptability of the finished Work.

EGAT or EGAT's representatives shall at all times have access to the Work whenever it is in preparation or progress and the Contractor shall provide proper facilities for such access and shall furnish promptly, without additional charge, all facilities, labor and material reasonably needed for safe and convenient inspection by EGAT or EGAT's representatives. The Contractor shall notify EGAT at least two (2) Months in advance

when and where the Equipment and the Work will be available for each inspection and test. Any expense incurred by EGAT or EGAT's representatives to inspect the Equipment and the Work or to attend the test caused by false call of the Contractor for inspection and tests shall be borne by the Contractor.

If any Work should be covered up, or otherwise made inaccessible, without the approval of EGAT, it shall, if required by EGAT, be uncovered and made accessible for examination. Any such cover, which is required in the finished Work, shall be restored to EGAT's satisfaction at the Contractor's expense.

The acceptance of any Work or Equipment covered by these Contract Documents, or the making or waiving of any inspection or witnessing of any tests shall in no way relieve the Contractor of full responsibility for the quality, character and satisfactory operation and performance of the complete Work, and every part of it, as outlined in these Contract Documents, nor shall it prejudice or affect the rights of EGAT as set forth in the Contract.

Unless otherwise specifically provided in the Contract, the expenses directly required for all labor, tools, instruments, other materials and Equipment necessary for performance of the tests shall be borne by the Contractor.

The Contractor shall at his own expense conduct shop tests in accordance with the Specifications and submit the results of the tests to EGAT upon completion of tests. EGAT reserves the right to inspect all Equipment either in person or via video conference during its manufacture or fabrication and prior to its preparation for shipment, to inspect its packing when ready for shipment, and to witness any or all tests.

In the event the results of the tests do not satisfy the requirements of the Specifications or the guaranteed performance, the Contractor shall rectify to improve the Equipment until satisfactory results are obtained and shall conduct all necessary retests at his own expense.

Any delay in delivery due to the retest shall not constitute a release of the Contractor from his responsibility for delay. Any expenses incurred by EGAT in attending these retests shall be borne by the Contractor.

EGAT reserves the right to send one or more of EGAT's employees, not as inspectors, to the Contractor's plant to witness the fabrication, assembly and testing of any or all parts of the Equipment being furnished under this Contract. Travelling expenses and per diem of such employee or employees shall be borne by EGAT.

E-14. Preparation for Shipment and/or Delivery

The Contractor shall submit shipment and/or delivery schedule for EGAT's approval at least thirty (30) Days in advance before each shipment and/or delivery is made. No shipment and/or delivery shall be made prior to EGAT's approval which will be notified to the Contractor within fifteen (15) Days after receipt of the said shipment and/or delivery schedule.

All imported and local Equipment to be delivered under this Contract shall be satisfactorily packaged in such a manner to protect them from damage during transportation and for outdoor storage at the site in hot, wet, humid and dusty conditions. In addition, the imported Equipment shall also be satisfactorily packaged for moist tropical ocean shipment. Where necessary, heavy parts shall be mounted on skids so that cable slings for handling can readily be attached. Where it is unsafe to apply external slings to a package, attached slings shall be provided and shall project through the package so that attachment can readily be made.

In order to keep the damage to non-water proof Equipment during the transportation at minimum level, the Contractor and/or supplier is required to put an umbrella mark on every package of the Equipment.

In order to accelerate the dispatch of the Equipment to the site, the Contractor is required to arrange packaging of the Equipment in such a manner that a complete set of one unit shall be packed in package(s) or crate(s) with indication of designated substation but each individual package or crate shall contain the Equipment for only one unit or part of a complete set of one unit or otherwise as directed in the Instructions for Packaging attached at the end of Section E. General Conditions.

For Power Transformer and Shunt Reactor, in addition, all accessories, which are packed in aforesaid manner shall be contained in a container per transformer except for transformer insulating oil, radiators and conservator including other accessories which for dimensional reason after packaging are unable to be contained in the said container. However, spare parts shall be contained in a separate container per each shipment or Contract to be awarded. The containers to be used shall become the property of EGAT. The dimensions of containers shall be as follows : -

<u>Container Dimensions</u>	<u>Door Dimensions</u>
Height 2.59 m.	Height 2.28 m.
Width 2.44 m.	Width 2.33 m.
Length 6.05 m.	

In addition, details of Equipment and substation destination per container shall be identified in Bill of Lading.

Detailed breakdown prices for spare parts of Equipment shall be also indicated in the invoice.

Prior to delivery of all Equipment, packaging details shall also be submitted to EGAT for approval.

The cost incurred for repair or replacement of any damages to the Equipment due to improper packaging shall be at the Contractor's expense.

Each individual package or crate shall be clearly and plainly tagged or marked for identification as follows:

EGAT, THAILAND

PROJECT NAME : _____

CONTRACT NO. : _____

SUBSTATION : _____

CASE NO. : _____

ITEM NO. : _____

DESCRIPTION : _____

EGAT'S SERIAL NO. : _____ (if any)

In addition to this, the following instructions shall be observed :

- a. Each box, crate, case, bundle or piece of loose Equipment shipped must show the following information clearly marked on its body :
 1. Gross weight in kilograms
 2. Net weight in kilograms
 3. Dimensions in centimeters
- b. All boxes, crates, cases, bundles, loose pieces, etc. must be marked consecutively from No. 1 upward throughout all shipments to completion of the order without repeating the same number.
- c. The packing list must indicate whether shipment is partial or complete, and shall incorporate the following information on each container, etc., according to its individual shipping number:
 1. Export case markings
 2. Case number
 3. Container number (for Power Transformer and Shunt Reactor)
 4. Item number
 5. Gross weight and net weight in kilograms
 6. Dimensions in centimeters
 7. Complete description of Equipment
 8. EGAT's serial No. (if any)

E-15. Clearance and Weight Limitations

The largest unloading facilities at Bangkok Wharf are 35 metric ton cranes. Lifts heavier than 35 tons will have to be handled by ocean freighter on-board lifting equipment. Ocean freighters of the 10,000 tons class regularly calling at Bangkok Wharf have off-loading capacities to handle 50 tons.

The largest unloading facilities at Laem Chabang Port are 30 metric ton cranes. Lifts heavier than 30 tons will have to be handled by ocean freighter on-board lifting equipment.

Generally, unloading at Thai Port and highway transportation are subject to the following limitations:

Dimensions	Limitations		
	Unloading at Bangkok Wharf/ Highway Transportation		Unloading at Laem Chabang Port/Maptaphut Port
Weight (tons)	60.0	>60.0-135.0	120.0
Width (meters)	3.5	3.5	4.5
Length (meters)	10.0	10.0	25.0
Height from Loading Platform (meters)	3.7	4.0	4.0

The Contractor shall therefore exercise due care to pack the Equipment to meet the above transport limitations.

For Power Transformer and Shunt Reactor, the shipping weight of the largest part is indicated in Ratings and Features.

E-16. Shipment

Shipment of Equipment from port of embarkation to the final port of discharge shall be effected by using Thai vessels through the sea freight forwarder appointed by the Contractor. The Contractor is required to notify EGAT of the name of the sea freight forwarder one (1) week prior to shipment.

According to the regulations of *the Maritime Promotion Division*, Marine Department (as amended from time to time), shipments by non-Thai vessels can be made after receipt of permission granted by *the Maritime Promotion Division*, Marine Department as requested by the Contractor.

The Contractor is, therefore, required to immediately contact *the Maritime Promotion Division*, Marine Department for such permission with supporting documents of the case thereof for arrangement of the permission in advance.

The Contractor shall follow all other regulations stated in the Mercantile Marine Promotion Act B.E. 2521 and the regulations of *the Maritime Promotion Division*, Marine Department (as amended from time to time).

The Contractor shall be liable for any and all costs and expenses, losses and/or damages suffered by EGAT as a result of the Contractor's failure to comply with such regulations.

For more information, the Contractor may contact *the Maritime Promotion Division, Marine Department at telephone No. 66 2233 1311-8 extension 387 and facsimile No. 66 2639 4778, <https://maritimepromotion.md.go.th/>*

All imported Equipment shall be shipped on Conference Line or on seaworthy oceangoing vessels which are members or associate members of the International Association of Classification Societies (IACS) and ISM Code Certified Vessels. Vessels over fifteen (15) years of age shall not be used for shipment under this Contract unless they : -

- a) have been used for the carriage of general cargo on an established and regular pattern of trading between a range of specified ports and do not exceed twenty-five (25) years of age, or
- b) were constructed as containerships, vehicle carrier or double-skin open-hatch gantry crane vessels (OHGCs) and have been continuously used as such on an established and regular pattern of trading between a range of specified ports, and do not exceed thirty (30) years of age.

Shipment shall be made under deck except for such Equipment which for dimensional reasons cannot be stowed in the vessels hold. In case Equipment cannot be stowed in the vessel hold, permission shall be obtained from EGAT prior to loading such Equipment on deck. Such approval shall not be unreasonably withheld. The Contractor shall in any case be responsible for proper packing for protection of such Equipment loaded on deck of the vessel. Shipment of all Equipment by dry cargo container will be accepted, but all the incidental expenses shall be borne by the Contractor.

For shipment of Equipment under this Contract, transshipment is allowed.

Any delicate Equipment, materials, instruments and tools including but not limited to computers, electronic parts, etc., shall be shipped by airfreight. The Contractor shall be responsible for proper packing for protection of such Equipment loaded on cargo hold of the aircraft.

Air freight shipment to airport of disembarkation in Thailand shall be effected through the air freight forwarder appointed by the Contractor. The Contractor is required to notify EGAT of the name of the air freight forwarder one (1) week prior to shipment.

E-17. Documents Required for Each Shipment

a. For Seafreight

For accounting procedure, the Contractor is required to send to EGAT the bill of lading, invoice and master packing list immediately by *letter submitted electronically or by electronic mail (E-mail)* but not later than three (3) Days after the Equipment are actually loaded free on board (FOB Vessel) at the port of Shipment.

One (1) original negotiable bill of lading, three (3) original signed invoices and packing lists shall be mailed directly to EGAT by express airmail within four (4) working days after the date of departure of the ocean-going vessel from the port of shipment.

Two (2) original negotiable and five (5) copies of non-negotiable bill of lading, ten (10) original signed invoices and three (3) copies of packing lists shall be submitted to EGAT through the Bank within the time as specified in the letter of credit. - This requirement is applied only in case payment is made by letter of credit.

b. For Airfreight

For accounting procedure, the Contractor is required to send to EGAT the airway bill, invoice and master packing list immediately by *letter submitted electronically or by electronic mail (E-mail)* but not later than three (3) Days after the Equipment are actually loaded on the air carrier at the airport of departure.

Three (3) original signed invoices and packing lists shall be attached to the airway bill and dispatched together with the airfreight shipment.

One (1) copy of airway bill, two (2) original signed invoices and packing lists shall be sent directly to EGAT by courier within four (4) working days after the date of departure of the carrier from the airport.

Two (2) copies of airway bill, ten (10) signed invoices and three (3) copies of packing lists shall be submitted to EGAT through the bank within the time as specified in the letter of credit. - This requirement is applied only in case payment is made by letter of credit.

To act in accordance with the rules and regulations of the Customs Department of the Kingdom of Thailand, as well as to enable EGAT to expedite clearing the Equipment from the Customs House accordingly, the following declarations, other than regular statements, have to be made in English in the invoice for any transaction concluded with EGAT.

- a. Country from which Equipment is purchased as well as country of origin; if the Equipment is produced in the country or group of countries where there are trade agreements between such country or group of countries and the Kingdom of Thailand, preferential treatment on import duty and taxes for importation of the Equipment is required;
- b. Electricity Generating Authority of Thailand as consignee and Thailand as consigning country
- c. Date and Number of Contract;
- d. Name of Project, if any;
- e. Marking and numbers, as well as gross weight and volume;
- f. Details of Equipment, i.e. names, kinds, qualities, quantities, net weights, and other particulars as available for each type including trademarks or other symbols of such Equipment. If there are no trademarks or symbols, the invoice shall indicate "no trademarks", "no symbols", as the case may be;
- g. Selling price or value of Equipment per unit expressed in the type of currency under transaction and representing actual price or value of Equipment as stated in the price schedules or price breakdown, as the case may be;

If the Contractor fails to specify the price or value of Equipment according to the Contract in the invoice prepared for shipment, the Contractor shall be held responsible for the following:

1. In case of over value or price of Equipment stated in the invoice, the Contractor shall be responsible for reimbursement to EGAT for the import duty and taxes (excluding value added tax) collected by the Customs Department and the insurance premium (excluding value added tax) on the over value or price of Equipment as well as interest. Value added tax imposed in connection thereto shall be EGAT's responsibility. The Contractor shall also refund to EGAT the amount of over value payment as well as interest. The interest to be applied under this Article shall be Minimum Overdraft Rate announced by Krung Thai Bank plus two (2) (MOR+2) percent calculated from the date of EGAT's payment of the over value payment, import duty and taxes as well as insurance premium until the date of the Contractor's settlement of the same in full.
2. In case of under value or price of Equipment stated in the invoice, the Contractor shall be responsible for reimbursement to EGAT the surcharges imposed on additional import duty and taxes at the rate currently established by

the Customs Department as well as interest (if any) and also shall be responsible for compensation to EGAT for cost incurred in repair or replacement of the damaged Equipment which is not covered by insurance due to under value or price of Equipment stated in the invoice.

- h. Other expenses:
 - 1. Packing charges (if any)
 - 2. Insurance premiums (if insured)
 - 3. Freight
 - 4. Others (if any)

The Contractor shall, at the time of shipment, prepare and submit a certificate of origin(s) for the Equipment required as per point a. above together with the invoice and other shipping documents for EGAT to obtain the benefit from preferential treatment on import duty and taxes for importation of the Equipment from the country or group of countries where there are trade agreements between such country or group of countries and the Kingdom of Thailand. For each shipment, all items of Equipment requiring certificate of origin shall be included in only one (1) certificate of origin except as otherwise specified in any trade agreement. The trade agreements shall include but not be limited to the following:

- 1. Common Effective Preferential Tariff (CEPT) Scheme for the ASEAN Free Trade Area (AFTA);
- 2. Agreement between the Kingdom of Thailand and Japan for an Economic Partnership; and
- 3. Agreement between the Government of the Kingdom of Thailand and the Government of the People's Republic of China on Accelerated Tariff Elimination under the Early Harvest Programme of the Framework Agreement on Comprehensive Economic Cooperation between ASEAN and China.

If the Contractor advises EGAT in writing before shipment that it is unable to provide a certificate of origin to EGAT, the Contractor shall be responsible for all costs incurred including but not limited to reimbursement to EGAT for the excess amount of the import duty and taxes (except value added tax) paid by EGAT to Customs Department.

Further to the above, if the Contractor delays to provide a proper certificate of origin to EGAT, the Contractor shall be responsible for all costs incurred including but not limited to reimbursement to EGAT for the storage charges and the interest on the excess amount of import duty and taxes (except value added tax) paid by EGAT to the Customs Department at the rate of Minimum Overdraft Rate announced by Krung Thai Bank plus two (2) (MOR+2) percent calculated from the date of EGAT's payment of import duty and taxes up to the date of receipt of the excess amount of import duty and taxes refund from the Customs Department.

However, if the Contractor fails to provide such proper certificate to EGAT, the Contractor shall be responsible for all costs incurred including but not limited to reimbursement to EGAT for the storage charges and the excess amount of import duty and taxes (except value added tax) paid by EGAT to the Customs Department as well as interest on the said excess amount of import duty and taxes at the rate of Minimum

Overdraft Rate announced by Krung Thai Bank plus two (2) (MOR+2) percent calculated from the date of EGAT's payment of import duty and taxes up to the date of acknowledgement that the certificate cannot be issued in conformity with requirement of the Free Trade Agreement.

The Contractor is also required to study the existing trade agreements and any new trade agreement between the Kingdom of Thailand and a country or group of countries published in the website of Customs Department (www.customs.go.th) and/or Ministry of Commerce (www.moc.go.th), and ask for more information from EGAT in order that EGAT can obtain the benefit from preferential treatment on import duty and taxes for importation of the Equipment from the country or group of countries where there are trade agreements between such country or group of countries and the Kingdom of Thailand.

Fullest conformity with the requirements of the Customs Department of the Kingdom of Thailand mentioned above is essential as a condition precedent.

Unless by force majeure, failure to furnish EGAT with these shipping documents and the certificate of origin within the specified period and strictly in accordance with conditions stipulated above thereby causing impossibility of making prompt customs clearance of the Equipment from Thai Port, the Contractor shall, upon receipt of the EGAT's notice, reimburse EGAT for go down rent / storage charge and other expenses arising from or in consequence of the nonconformity with the above specified requirement.

E-18. Force Majeure

The Contractor shall not be in default under this Contract because of any delays in delivery or in completion of the Work on the separable parts thereof which delays are caused by force majeure; provided, that the Contractor shall notify EGAT in writing of the cause of any such delay within fifteen (15) Days after the end of the event which results in the delay. Upon receipt of any such notice of delay, EGAT will promptly ascertain the facts and the extent of the delay and will extend the time for the delivery and assembly of the Equipment or the time for completing the Work when, in the opinion of EGAT, the delay is caused by force majeure or the findings of fact to justify an extension. EGAT's decision shall be binding on the Contractor, subject to the provision of Article E-31. Dispute Resolution included in these General Conditions.

"Force Majeure" shall be defined as any event, the happening or pernicious results of which could not be prevented even though a person against whom it happened or threatened to happen were to take such appropriate care as might be expected from him in this situation. (Normal rains, inundation, dearth of water, and the overturning or sinking of barges in canals, rivers, or streams and similar events shall not be considered as force majeure).

E-19. Transportation Insurance

Transportation insurance from the port of shipment/from the Contractor's premise(s) to EGAT's Store and/or EGAT's site will be under the responsibility of EGAT.

E-20. Transfer of Title

The title of ownership for the Equipment furnished under this Contract shall be passed to EGAT at the time the Equipment is actually loaded onto the vessel at the port of shipment, or into charge of the air carrier at the port of departure, or at the time the Equipment is actually delivered ex-works and the Contractor's statement or delivery order confirming delivery of the Equipment ex-works has been certified by EGAT's representative. However, this transfer of title shall not be construed as an acceptance of the Equipment. The Contractor shall continue to be responsible for the quality and performance of the Equipment, and for their compliance with the Specifications as well as any loss, theft or damage of the Equipment during the course of execution of the Contract, until final acceptance of the Work by EGAT and the fulfillment of the guarantee provision of the Contract.

E-21. Changes and Extra or Omitted Work

EGAT may at any time authorize changes in, additions to, or deductions from the Equipment to be furnished under the Contract. Changes, additions, or deductions shall be authorized only by written notice served by EGAT upon the Contractor and such notice shall be treated as an integral part of the Contract. Adjustments, if any, in the amounts to be paid to the Contractor by reason of any such change, addition, or deduction shall be determined by one or more of the following methods :

- a. by unit price contained in the Price Schedules
- b. by an acceptable lump sum or unit price proposal from the Contractor
- c. on a cost-plus limited basis not to exceed a specific limit. A cost-plus limited basis is defined as the cost of Equipment, labor, and insurance, plus fifteen (15) per cent of the said cost to cover superintendence, general expense, and profit.

No claim for an addition to the Contract Price shall be valid unless authorized as described in this Article. If the parties are unable to agree to the method to be employed in determining adjustments in the Contract Price, the method shall be determined by EGAT.

E-22. Termination and Suspension of Contract

EGAT may, by written notice sent to the Contractor, terminate the Contract, in whole or in part, at any time for its convenience. The notice of termination shall specify that termination is for EGAT's convenience, the extent to which performance of work under the Contract is terminated, and the date upon which such termination becomes effective.

The Equipment that are completed and ready for shipment within thirty (30) Days after the Contractor's receipt of notice of termination shall be purchased by EGAT at the Contract terms and prices. For the remaining Equipment, EGAT may elect :

- a. to have any portion completed and delivered at the Contract terms and prices and/or
- b. to cancel the remainder and pay to the Contractor an agreed amount for partially completed Equipment and for materials and parts previously procured by the Contractor.

E-23. Default and Termination

Should the Contractor :

- a. fail to furnish the Equipment or carry out the Work in accordance with this Contract; or
- b. refuse or fail to prosecute the Work or any part thereof which shall ensure its completion within the time specified in this Contract or any authorized extension of time by EGAT; or
- c. fail to furnish the Equipment and/or complete the Work or any part thereof within the time specified in this Contract or any authorized extension of time by EGAT; or
- d. commit any breach or fail to comply with any of the provisions of this Contract; or
- e. notify EGAT in writing that the Contractor is unable or unwilling to furnish the Equipment or complete the Work or any part thereof; or
- f. become insolvent or bankrupt or make an arrangement or composition with the Contractor's creditors or, being a corporation, go into liquidation whether compulsory or voluntary (except for the purpose of reorganization); or
- g. by himself or by any person on his behalf, give or offer any money or benefit of forbearance to any employee of EGAT and/or any employee of the Engineer who has duties or responsibilities in connection with the acceptance of the proposal or the making of this Contract;

then, in any of such events, the Contractor shall be in default under this Contract, and EGAT may at his sole discretion take any one or more of the following actions that it considers appropriate :

- (i) suspend payments under this Contract until the default has been rectified;
- (ii) cancel or terminate the Contract in whole or in part;
- (iii) take that part of the furnishing of Equipment or the Work, in respect of which the delay or default has occurred, out of the hands of the Contractor or any other person in whose control or possession it is;
- (iv) reduce the Contract Price by an amount equal to the reduction in value to EGAT of the Equipment as actually delivered.

The Contractor shall be liable for all losses and/or damages including but not limited to the increased installation costs and increased administrative costs, suffered by EGAT as a result of the Contractor's default. The Contractor shall have no claim for payment with respect to Work thereafter performed.

All such damages may be recovered by EGAT from the Contractor in any court of competent jurisdiction or, without prejudice to that right, by deduction from any money due or becoming due to the Contractor under this Contract, or from any security deposited, or, after use of the property and materials of the Contract for completion of the work, as provided in this Contract, such property and materials may be sold and the proceeds shall be applied to any remaining obligations of the Contractor.

E-24. Indemnification by the Contractor

The Contractor shall fully indemnify and hold harmless EGAT and its employees and officers from and against any and all suit, actions or administrative proceedings, claims (including any claim for copyright or patent infringement), demands, losses, costs, expenses (including attorney's fees and expenses) and damages of whatsoever nature except breach or default, in respect of death or injury of any person or loss of or damage to any property caused by any act or omission of the Contractor or the Contractor's own officers, directors, agents, employees, Contractors or Subcontractors arising in any manner whatsoever, except any injury, death or property damage caused by the negligence of EGAT, its contractors, employees, officers or agents.

E-25. Limitation of Liability

The liability of the Contractor to EGAT arising from default or termination under the Contract in aggregate shall not exceed the total Contract Price.

E-26. Consequential Damages

Neither party shall be liable to the other party for any indirect, incidental, consequential or punitive damages as a result of the performance or nonperformance of the obligations imposed pursuant to this Contract, unless such indirect, incidental, consequential or punitive damages are foreseen or could have been foreseen at the time of execution of the Contract.

E-27. Vesting of Contract in Receiver

If the Contractor shall compound with his creditors, or shall become bankrupt or insolvent, or carry on business under a receiver, or become incapable from any cause whatsoever of carrying out the Work, any such receiver or any person in whom by law the Contract shall become vested, shall forthwith give notice to EGAT of the fact that the Contract has become vested in it and shall take all reasonable steps to carry on the Work at a rate fulfilling the Contract requirements. Thereupon, if EGAT so desires, such receiver or other such person as aforesaid shall have the option, during the period of one (1) Month from the date when the Contract becomes so vested in it, of carrying out the Contract. In the event of the Work being stopped, this option shall be opened only for a period of fourteen (14) Days from the stoppage date. In the event of the receiver or such other person not electing to carry out the Contract or EGAT not approving the carrying out of the Contract by the receiver, the Contractor shall then be in default and EGAT may proceed in accordance with Article E-23. Default and Termination.

E-28. Extension of Time

If, by reason of any of the following :

- a. Negligence or default on the part of EGAT or its agents,
- b. Alteration in or addition to the Work,
- c. Suspension of the Work at the written direction of EGAT for reasons beyond the control of the Contractor,
- d. War, insurrection, riot or civil commotion or delay caused thereby,
- e. Strikes, not caused by the Contractor's management,
- f. Lawful order of civil or military authorities,
- g. Unusually natural calamities, acts of God,
- h. Any other unforeseen circumstance beyond the Contractor's control.

The Contractor claims that he has been unduly delayed in the progress of the Work, he shall make written request to EGAT for an extension of time for completion of the Work or any portion of it.

Should EGAT consider such claim to be valid, it will grant such extension of time as may seem reasonable to EGAT, without thereby prejudicing or in any manner affecting the validity of the Contract. No extension of time will be granted unless the Contractor makes the written request within fifteen (15) Days after the end of the event which results in the delay.

Other than claiming an extension of time for completion of the Work or any portion of it, the Contractor shall not have any further recourse or claim against EGAT, nor shall he have any right of action against EGAT for loss or damage suffered by reason of such delay.

E-29. Failure to Meet Requirements

EGAT shall have the right to require the Contractor to make any changes in the Equipment or Work covered by this Contract, which may be necessary in the opinion of EGAT, to make the Equipment or Work conform to the requirements of the Contract Documents, without additional cost to EGAT. Any defects in the Equipment or workmanship or other failure, to meet the requirements of the Contract, including errors and omissions on the part of the Contractor, which are disclosed prior to final payment or prior to acceptance by EGAT,

or after completion of all tests, whichever occurs at the later date, shall, if so directed by EGAT, be corrected or replaced promptly by the Contractor at the expense of the Contractor.

In case of replacement of Equipment due to non-conformity with EGAT's specifications and/or defects found prior to acceptance of Equipment by EGAT or replenishment for short pack or returning of repaired Equipment due to such defect, the Contractor shall, upon receipt of EGAT's written notice supported with the receipt issued by the relevant parties, be responsible for reimbursement of the expenses incurred for the following :

- All re-export charges (if any)
- Import duty and taxes
- Landing charges, rents and handling charges (ocean freight)
- Storage charges (air freight)
- Truck hire
- Labour charges

These expenses shall exclude value added taxes, which will be EGAT's responsibility.

The contractor shall be also responsible for reimbursement of Service charges for customs clearance (if any) including value added tax.

Any latent defects not disclosed prior to the date of final payment or prior to acceptance or after completion of all tests, whichever occurs at the later date, but disclosed within the guarantee period as specified in Article F-10.a., shall be corrected or replaced promptly by the Contractor at the expense of the Contractor, except that the cost of import duty and taxes, inland transportation and installation of the replacement parts for foreign supply Equipment, and the cost of inland transportation and the installation of the replacement parts for local supply Equipment will be borne by EGAT.

For Equipment specified in Data Sheet, in case EGAT, at its sole discretion, requires the Contractor to replace any defected Equipment, the Contractor shall replace the Equipment with the whole new set at its own costs and expenses including the cost of all re-export charges (if any), import duty and taxes, landing charges, rents and handling charges (ocean freight), storage charges (air freight), truck hire, labour charges, service charges for customs clearance, inland transportation and installation of the Equipment.

The Contractor shall extend the provisions of his liability to cover all repair and replacement parts furnished from the day immediately following the date of completion of such repair or replacement as follows:

Time of Malfunctioning and/or Defect Found	Guarantee Period Extension				
	Equipment with 1-Year guarantee period	Equipment with 2-Year guarantee period	Equipment with 3-Year guarantee period	Equipment with 4-Year guarantee period	Equipment with 5-Year guarantee period
First Year	For a new period of one (1) Year.	For a new period of two (2) Years.	For a new period of three (3) Years.	For a new period of four (4) Years.	For a new period of five (5) Years.
Second Year	n/a	For a new period of one (1) Year.	For a new period of two (2) Years.	For a new period of three (3) Years.	For a new period of four (4) Years.
Third Year	n/a	n/a	For a new period of one (1) Year.	For a new period of two (2) Years.	For a new period of three (3) Years.
Fourth Year	n/a	n/a	n/a	For a new period of one (1) Year.	For a new period of two (2) Years.
Fifth Year	n/a	n/a	n/a	n/a	For a new period of one (1) Year.

The Contractor shall, if required by EGAT in writing, search under the directions of EGAT for the cause of any defect, imperfection or fault appearing prior to the acceptance of Equipment or in the period of maintenance guarantee. Unless such defect, imperfection or fault shall be one for which the Contractor is liable under the Contract, the cost of the work carried out by the Contractor in searching as aforesaid shall be borne by EGAT. If such defect, imperfection or fault shall be one for which the Contractor is liable under the Contract, the cost of the work carried out in searching as aforesaid shall be borne by the Contractor and he shall in such case repair, rectify and make good such defect, imperfection or fault at his own expense.

E-30 Operation or Use of Unsatisfactory Equipment

If the operation or use of the Equipment proves to be unsatisfactory to EGAT, EGAT shall have the right to operate and use such Equipment until they can be taken out of service for correction by the Contractor of such latent defects, error, or omissions and for replacement in whole or in part, if correction is unsuccessful or infeasible. The period of such operation or use shall not exceed one (1) Year from the day immediately following the date of acceptance of Equipment by EGAT.

E-31. Dispute Resolution

Any dispute arising out of or in connection with this Contract, interpretation, breach, or termination thereof shall be settled by amicable discussion between authorized representatives of each Party. Either Party may at any time send a written notice to the other Party requesting for an appointment of authorized representative for a settlement of any dispute hereunder. The Parties agree to make diligent and good faith attempt to resolve such dispute in an equitable manner. If the authorized representatives of both Parties are unable to resolve such dispute within 30 Days after commencement of the discussion for dispute resolution or other extended period of time as mutually agreed by both Parties, either Party may file a lawsuit to the court having jurisdiction in Thailand for settlement of such dispute. Each Party agrees that the final court judgment shall be conclusive and binding upon the Parties.

Pending decision of the court, both Parties shall continue to perform their respective obligations under this Contract.

E-32. Language and Numbers

All drawings, designs, specifications, manuals, nameplates, markings, operating instructions, statements, schedules, notices, documents, and all written communications between EGAT and the Contractor, concerning this Contract, shall be in the English language and in the metric system of weights and measures unless otherwise specified.

SPECIMEN OF GUARANTEE

To :

Date

Electricity Generating Authority of Thailand
Bangkrui, Nonthaburi, 11130

Thailand

Re : Performance Security for Contract No. _____

Gentlemen :

In accordance with the provision of the Contract for _____ No. _____ (hereinafter referred to as the Contract) the contents of which have been noted by us that Messrs. _____ (hereinafter referred to as the Contractor) has to deposit with Electricity Generating Authority of Thailand (hereinafter referred to as EGAT) a Performance Security for the proper and faithful performance of the Contract in the amount of _____ (in words : _____) which is _____ per cent, round up to the nearest whole number, of the total Contract Price, we, the _____ as instructed by the Contractor, agree unconditionally to irrevocably guarantee as primary Obligor, the payment to EGAT on its first demand, without whatsoever right of objection on our part and without its first claim to the Contractor, in the amount not exceeding : _____ (in words : _____) in the event the obligations expressed in the above mentioned Contract have not been fulfilled by the Contractor, giving EGAT the right of claim for penalty, damages, liquidated damages or any expenses for which the Contractor may become liable to EGAT under the Contract.

We further agree that no extension of time, change in, addition to or other modification of terms of the Contract or Work to be performed thereunder, or of the Specifications or other Contract Documents, which may be made between EGAT and the Contractor, shall in any way release us from any liability under this guarantee, and we shall thereby waive notice of any such change, addition or modification.

This Performance Security shall be valid and remain in full effect from the date of execution of the Contract until the issuance of the Acceptance Certificate by EGAT or the acceptance of Equipment deemed to be made by EGAT against submission by the Contractor of the Maintenance Security accepted by EGAT.

Yours very truly,

Authorized Signature

Instructions for Packaging

Name of Equipment	Packed per complete set of one unit/units	Packed per Substation
1. Power Transformer	√(1)	-
2. Distribution Transformer	√(1)	-
3. Shunt Reactor	√(1)	-
4. Surge Arrester	√(1)	-
5. Current Transformer	√(1)	-
6. CC, CCVT, VT	√(1)	-
7. GIS	-	√
8. Shunt Capacitor Bank	√(1)	-
9. Power Circuit Breaker	√(1)	-
10. Disconnecting Switch	√(1)	-
11. AC/DC Dist. Board, LCUS, LRP	√(1)	-
12. Stationary Battery	√(1)	-
13. Lighting Fixture	-	√
14. Identification and Danger Notice Plate	-	√
15. Control and Protection System	√(1)*	-
16. Computerized Control System	-	√
17. Power Line Carrier	-	√
18. Teleprotection	-	√
19. Line Trap	-	√
20. Battery Charger	√(1)	-

- Note :
1. Number in parenthesis represents maximum number of complete set of one unit/units packed in an individual package or crate.
 2. * In case of spare for control and protection system, such Equipment shall be packed per board, but in case of loose control and protection system, such Equipment of whichever substation shall be packed in the same package or crate of that substation.
 3. Other substation Equipment not mentioned shall be packaged in such a manner that it will not cause unreasonable expenses or delay to EGAT in distribution of such Equipment to the designated substation.
 4. Prior to delivery of all Equipment, packaging details shall be submitted to EGAT for approval.

DRAFT

SECTION F
SPECIAL CONDITIONS

SPECIAL CONDITIONS

F-1. Scope of Work

The Contractor shall perform, furnish and deliver the Equipment as required by these Contract Documents.

For imported Equipment, Transportation from Thai Port to sites shall be EGAT's responsibility. However, the Contractor shall, at his own expenses and responsibility, perform unloading the Equipment at the port or airport of disembarkation in Thailand.

For local supply, Transportation from the Contractor's premises to the sites shall be EGAT's responsibility. However, the Contractor shall, at his own expenses and responsibility, perform loading the Equipment on EGAT's trucks or trailers at the Contractor's premises and shall be liable for all losses and/or damages to the Equipment as well as any expenses causing therefrom.

F-2. Responsibility of Contractor

The Contractor shall be solely responsible for ensuring that the Work throughout is executed in the most substantial, proper and workmanlike manner, with the best quality materials and conforming to the best engineering practice for the operating conditions specified; the drawings and quality control are performed or made in accordance with the Contract; and services reasonably to be furnished though not specifically provided in the Contract are furnished; all to EGAT's entire satisfaction notwithstanding that certain portions of the work may be executed by the Subcontractor.

F-3. Cooperation with Other Contractors

The Contractor, if required, shall exchange with other Contractor furnishing associated Equipment, all necessary drawings and other information required to insure the complete and proper design and manufacture of the Equipment to be furnished under these Specifications. One (1) copy of all drawings and correspondence, relating to information interchanged between Contractors, shall be sent to EGAT in Nonthaburi, Thailand.

***F-4. Supervision of Installation**

Subject to the desire and decision of EGAT, the Contractor may be required to furnish the services of qualified and experienced supervisor(s) who has at least three years experience on the particular Work required under the Contract and shall be the permanent employee of the manufacturer of the Equipment. For 230 kV (or lower) Power Circuit Breaker and 115 kV (or lower) Gas-Insulated Switchgear, the permanent employee of the representative of the manufacturer is acceptable, provided that such employee is certified by the manufacturer.

The scope of responsibility of the supervisor on behalf of the Contractor is as follows :

- a. Supervise and be responsible for the installation, erection, adjustment, field test and commissioning of the Equipment.
- b. Prepare formulation sheets for a check list, test sheet, release form and field report to be discussed with EGAT before performing the installation work.
- c. Submit four copies of report summarizing the work performance, from the beginning to the completion of the supervisory period, to EGAT within one month after finish the installation work or final inspection. The report shall include the following :
 1. Note on pending matter i.e. faulty and omitted equipment, performance deficiency etc.
 2. Problem concerning installation performance.
 3. Photographs showing progress of the installation work periodically until the work is completed.

The Contractor shall, in each and every instance, cooperate fully with the construction personnel installing and/or operating the Equipment and the Work, the operations of the supervisor shall be coordinated with the program of construction at the site as directed by EGAT.

The supervisor shall report at EGAT in Nonthaburi, Thailand, on the date designated by EGAT after a reasonable advance notice from EGAT, and shall remain until the Equipment have been in satisfactory operation for at least ten (10) working days as determined by EGAT, unless released earlier by EGAT.

The installation supervisor must be able to understand, speak, read and write the English language fluently. Should an interpreter be necessary, the cost of such interpretation service shall be at the Contractor's expense.

*If installation supervisor is required as specified in Price Schedule, this provision shall apply to this Contract.

F-5. Acceptance Tests

After the Equipment have been installed and placed in satisfactory operation, they may be tested by and at the expense of EGAT to determine whether or not all requirements of these Contract Documents have been met and the Contractor's guarantees have been fulfilled. The Contractor will be permitted to have his representative present at his own expense. If the tests show that the requirements or guarantee have not been met, the Contractor shall, at his own expense, make all necessary corrections. Additional tests will then be made to demonstrate to EGAT's satisfaction the effectiveness of these corrections. These additional tests will be at the Contractor's expense. Unless the necessary corrections have been made, the conditions of the Contract shall be considered unfulfilled.

All tests will be performed in accordance with the latest applicable Test Codes, unless otherwise stated.

F-6. Failure to Meet Performance Guarantees

If EGAT elects to accept the Equipment which do not meet any performance guarantee or which do not meet other requirements of these Contract Documents, as may be determined by factory test, field test or operation under service conditions, appropriate adjustment will be made of the Contract Price for such Equipment; provided that no such adjustment will be made until after the Contractor has been given a reasonable opportunity to repair, improve, or replace defective Equipment or parts thereof wherever practicable.

F-7. Acceptance Certificate

When EGAT is satisfied with the Equipment or agrees to accept the Equipment under the provision of Article F-6. Failure to Meet Performance Guarantees and there are no major unsettled claims against the Contractor by EGAT, EGAT will issue a written Acceptance Certificate against submission by the Contractor of maintenance security(ies) as specified in Article F-12. Maintenance Security and effective for a period of time as specified in Article F-10.a.

The Acceptance Certificate will list all deficiencies and reservations as a result of the inspection and tests performed, if any.

The purpose of the maintenance security is to guarantee the proper functioning of the Equipment supplied by the Contractor with a provision that the effective period of the maintenance security shall automatically be extended in case that the obligations stipulated in Article F-10. Maintenance Guarantee are not fulfilled.

A form of maintenance security acceptable to EGAT is shown in Article F-12. Maintenance Security.

F-8. Payment

Payment in foreign currency will be made in the currency or currencies in which the price has been stated in the price schedules. The Contractor has to inform EGAT the mode of payment he requires for payment for foreign currency portion together with detail of bank account No., beneficiary's name and address etc. If the Contractor requires the payment of foreign currency portion to be paid directly to the suppliers, he has to inform EGAT which portion of the Contract Price, as stipulated in the term of payment of the Contract, to be paid accordingly. In case the local Contractor requires foreign currency or currencies to be paid directly to him, payment of such foreign currency or currencies will be made to the local Contractor in Thai Baht by using the selling exchange rate published by the Bank of Thailand on the payment date.

In case the Contractor requires the payment of foreign currency portion to be made through letter of credit, EGAT will, if there is no fault or any delay caused by the Contractor, establish the letter of credit in the name of the Contractor or Suppliers not later than thirty (30) Days after signing the Contract. The Contractor shall be responsible for all bank charges inside and outside Thailand and including opening, amendment, reimbursing charges, payment commission, cable charges, discrepancy fee, acceptance commission and others (if any) arising from Letter of Credit.

Payment in local currency will be made directly by EGAT.

The Contractor or beneficiary has to inform EGAT by mailed letter or *letter submitted electronically or by electronic mail (E-mail)* immediately the date upon which he has received the original letter of credit *to be* opened in his favour.

Payment will be made in the following manner :

a. Payment for Equipment (except Spare Parts and Optional Items)

Foreign Supply

1. Eighty (80) per cent of the Contract Price will be paid after delivery FOB Port of Shipment (FOB Vessel) on the basis of pro rata value of each shipment against presentation of invoices, shipping documents, EGAT's letters of approval for shipment and EGAT's letter of approval for test report* of the relevant Equipment including EGAT's letter(s) of approval for final drawings only for Control and Protection Equipment.

*Test report means the report of tests specified in Article E-13. Inspection and Tests.

2. Ten (10) per cent of the Contract Price of each Schedule will be paid against presentation of Drawing and Document Acceptance Certificate to be issued by EGAT to certify the receipt of all drawings and documents required from the Contractor under Article F-11. Drawings and Documents to be Furnished by Contractor for such schedule, provided that payment shall not be made until EGAT has received from the Contractor the original signed negotiable Bill of Lading and appertaining documents giving evidence of shipment of the main Equipment of that Schedule.
3. Ten (10) per cent of the Contract Price of each Schedule will be paid after the Equipment have been installed, tested and operated or used for a period of 30 Days and the acceptance of the said Equipment has been made by EGAT against presentation of Acceptance Certificate to be issued by EGAT and submission of maintenance security by the Contractor. EGAT will list the minor pending claim(s), if any, and payment will be made by deducting such claimed amount.

However, if, through no fault of the Contractor or of the Equipment, such installation, test and operation or use of the Equipment are delayed beyond a period of six (6) Months after complete delivery at Thai Port; payment of this ten (10) per cent will be made as soon as possible but not later than the ninth (9th) Month after complete delivery and it shall be deemed as if acceptance of Equipment is made by EGAT at the end of the said sixth (6th) Month and the guarantee period shall start therefrom against submission of maintenance security by the Contractor.

In case there is some minor claim(s) or minor fault of the Contractor, the payment of this ten (10) per cent shall be made by deducting such claimed amount and the guarantee period of this part will start after such minor claim(s) has been settled by the Contractor and acceptance of which has been made by EGAT.

Local Supply

1. Eighty (80) per cent of the Contract Price will be paid on the basis of pro rata value of each delivery against presentation of the Contractor's statement or delivery order confirming the ex-works delivery of Equipment duly certified by EGAT's representative*, EGAT's letters of approval for delivery and EGAT's letter of approval for test report** of the relevant Equipment including EGAT's letter(s) of approval for final drawings only for Control and Protection Equipment.

*EGAT's representative means the authorized EGAT's Store personnel to verify the quantity of Equipment according to the packing list to be delivered to the Site.

**Test report means the report of tests specified in Article E-13. Inspection and Tests.

2. Ten (10) per cent of the Contract Price of each Schedule will be paid against presentation of Drawing and Document Acceptance Certificate to be issued by EGAT to certify the receipt of all drawings and documents required from the Contractor under Article F-11. Drawings and Documents to be Furnished by Contractor for such schedule, provided that payment shall not be made until EGAT has received from the Contractor the statement or delivery order and appertaining documents giving evidence of delivery of the main Equipment of that Schedule.
3. Ten (10) per cent of the Contract Price of each Schedule will be paid after the Equipment have been installed, tested and operated or used for a period of 30 Days and the acceptance of the said Equipment has been made by EGAT against presentation of Acceptance Certificate to be issued by EGAT and submission of maintenance security by the Contractor. EGAT will list the minor pending claim(s), if any, and payment will be made by deducting such claimed amount.

However, if, through no fault of the Contractor or of the Equipment, such installation, test and operation or use of the Equipment are delayed beyond a period of six (6) Months after complete ex-works delivery; payment of this ten (10) per cent will be made as soon as possible but not later than the ninth (9th) Month after complete delivery and it shall be deemed as if acceptance of Equipment is made by EGAT at the end of the said sixth (6th) Month and the guarantee period shall start therefrom against submission of maintenance security by the Contractor.

In case there is some minor claim(s) or minor fault of the Contractor, the payment of this ten (10) per cent shall be made by deducting such claimed amount and the guarantee period of this part will start after such minor claim(s) has been settled by the Contractor and acceptance of which has been made by EGAT.

b. Payment for Spare Parts

One hundred (100) per cent will be paid after complete delivery against presentation of invoices, shipping documents and EGAT's letter of approval for shipment for foreign supply or the Contractor's statement or delivery order confirming the delivery of Equipment ex-works duly certified by EGAT's representative* and EGAT's letter of approval for test report** of the relevant Equipment and the acceptance has been made by EGAT. The guarantee period shall start from the day immediately following the date of the acceptance of the Spare Parts.

*EGAT's representative means the authorized EGAT's Store personnel to verify the quantity of Equipment according to the packing list to be delivered to the site.

**Test report means the report of tests specified in Article E-13. Inspection and Tests.

c. Payment for Optional Items

Payment for Equipment

One hundred (100) per cent will be paid after complete delivery with presentation of invoices, shipping documents and EGAT's letter of approval for shipment and the acceptance has been made by EGAT. The guarantee period shall start from the day immediately following the date of the acceptance of Equipment.

Payment for Mechanical Operation Life Test (if any)

One hundred (100) per cent of the cost of the Mechanical Operation Life Test will be paid after the test has been performed successfully and test report has been accepted by EGAT.

d. Payment for Field Test Cost

One hundred (100) per cent of Field Test Cost will be paid after the test has been performed successfully and the test report has been accepted by EGAT.

e. Payment for Installation Supervisor

Payment for the services of the installation supervisor will be made within thirty (30) Days after his release by EGAT. Payment will be made on the basis of actual working man-days at the quoted cost per man-day up to a maximum equal to the total man-days quoted. For man-days exceeding the quoted total man-days, no payment shall be made by EGAT unless the Contractor can claim for any delays in

the progress of the work caused by EGAT. Any such additional man-days approved by EGAT shall be paid on the basis of the quoted man-day rate.

The number of quoted man-days shall include Sundays and shall cover a seven (7) day workweek, if required by the construction program. The working hours shall be forty-eight (48) hours per week, eight (8) hours per day, the working hours over 8 hours per day if requested by EGAT will be counted as overtime at 1½ times the regular hourly rate.

The amount to be paid for each Day for the services of the supervisor shall include for all salary, subsistence expense, insurance, compensations and personal expense of the supervisor, and all liabilities and responsibilities thereto. EGAT will pay for round-trip economy class air transportation for the installation supervisor between the Contractor's home office and Bangkok by the most expeditious and direct route on trip basis by draft after receipt of the Contractor's invoice supported with the used air ticket of such supervisor. The remission of immigration fees and taxes collectible by the Kingdom of Thailand shall not be paid by EGAT, as described in Article E-11. Fees and Duties.

After each payment is made, the Contractor or beneficiary shall issue and submit the receipt to EGAT at e-mail : FFMS@egat.co.th within three (3) calendar days upon receipt of such payment. The details of receipt shall include but not be limited to the following:

- *Company name and address*
- *The receipt date of payment*
- *Lists of Goods/Services the payment is made for*
- *Payment amount in numbers and in words*
- *Recipient signature*

F-9. Liquidated Damages for Late Delivery of Equipment

In the event of failure by the Contractor to make delivery of any Equipment within the time set forth in the Contract, plus any extension thereof authorized by EGAT as provided in the Contract, such failure shall be a default under the Contract for which the Contractor shall be liable for payment to EGAT as liquidated damages at the rate specified in Data Sheet.

Whenever any Equipment under any item is to be used together with other Equipment in other item as specified in Price Schedule as a complete set or unit, the Contractor shall make sure that they shall be shipped together as a complete set or unit. Failure on the part of the Contractor to comply with this requirement, the liquidated damages for late delivery of partial shipment shall be imposed on the Contractor for the whole amount of the Contract Price of such related items.

Notwithstanding, in case the Contractor fails to make delivery of minor part of any Equipment within the time set forth in the Contract and such late delivery does not have any effect to the performance of the Equipment, the Contractor shall be liable for payment to EGAT as liquidated damages at the rate of one-tenth of one (0.10) per cent of the total price of the minor part of the Equipment not timely delivered for each Day of delay. The price of such delayed minor part of the Equipment shall be determined by EGAT. EGAT shall, at his own discretion, determine whether such late delivery Equipment is the minor part and has any effect to the performance of the Equipment or not.

The payment of such liquidated damages shall not relieve the Contractor of his obligations to complete the Work under the Contract.

In case any Equipment is defective or does not conform to the requirements or specifications of the Contract where replenishment or correction or replacement must be made by the Contractor as per Article E-29. Failure to Meet Requirements, it shall be deemed that such Equipment has not yet been delivered unless such Equipment has been replenished or corrected or replaced, as the case may be, and delivered to EGAT at the delivery point specified in the Contract.

Payment of liquidated damages is contingent exclusively upon late delivery; in no case shall EGAT be required to substantiate any claim for payment of liquidated damages with proof of loss and/or damages. The liquidated damages shall be calculated for each Day of delay until the Equipment is delivered to EGAT excluding a period of time from the actual delivery date at the delivery point set forth in the Contract until the issuance of notification of defect or short pack or out of specification made by EGAT to the Contractor. This sum is payable regardless of the actual loss and/or damages incurred.

The Contractor shall not be liable for liquidated damages in the event of delay caused by force majeure.

F-10. Maintenance Guarantee

- a. The Contractor shall guarantee the proper functioning of the Equipment for a period as specified in Data Sheet from the day immediately following the date of acceptance of Equipment by EGAT; provided, however, that should any malfunctioning and/or latent defect in Equipment under normal use and service be found during the said period, and such malfunctioning and/or defective portion be repaired or replaced as stipulated in (c) and (d) hereinafter, then the guarantee period for such portion shall be extended from the day immediately following the date of completion of such repair or replacement as follows:

Time of Malfunctioning and/or Defect Found	Guarantee Period Extension				
	Equipment with 1-Year guarantee period	Equipment with 2-Year guarantee period	Equipment with 3-Year guarantee period	Equipment with 4-Year guarantee period	Equipment with 5-Year guarantee period
First Year	For a new period of one (1) Year.	For a new period of two (2) Years.	For a new period of three (3) Years.	For a new period of four (4) Years.	For a new period of five (5) Years.
Second Year	n/a	For a new period of one (1) Year.	For a new period of two (2) Years.	For a new period of three (3) Years.	For a new period of four (4) Years.
Third Year	n/a	n/a	For a new period of one (1) Year.	For a new period of two (2) Years.	For a new period of three (3) Years.
Fourth Year	n/a	n/a	n/a	For a new period of one (1) Year.	For a new period of two (2) Years.
Fifth Year	n/a	n/a	n/a	n/a	For a new period of one (1) Year.

The premium for the maintenance guarantee shall be paid by the Contractor.

- b. On the expiration of the maintenance guarantee period and if the Equipment is functioning normally, the Contractor shall thereafter be released of all obligations and responsibilities under the Contract and the maintenance security deposited in accordance with Article F-7. Acceptance Certificate, will be released and returned to the Contractor.
- c. If during the guarantee period EGAT finds any malfunctioning and/or defect in the Equipment, EGAT shall inform without delay the Contractor thereof, stating in writing the nature of the malfunctioning and/or defect, and the Contractor shall promptly commence to repair and make good or replace such malfunctioning and/or defect at the expense of the Contractor, except that the cost of import duty and taxes,

inland transportation and installation of the replacement parts for foreign supply Equipment, and the cost of inland transportation and the installation of the replacement parts for local supply Equipment will be borne by EGAT.

For Equipment specified in Data Sheet, in case EGAT, at its sole discretion, requires the Contractor to replace any defected Equipment, the Contractor shall replace the Equipment with the whole new set at its own costs and expenses including the cost of all re-export charges (if any), import duty and taxes, landing charges, rents and handling charges (ocean freight), storage charges (air freight), truck hire, labour charges, service charges for customs clearance, inland transportation and installation of the Equipment.

- d. If, after the repair or replacement performed in accordance with this Article, such Equipment continues to show malfunctioning and/or defect, EGAT may, at its option, demand further repair or replacement, and reserve the right to claim damages, if applicable, arising therefrom.
- e. If the Contractor fails to take action for starting up the necessary works for repair or replacement within fourteen (14) Days after receipt of EGAT's written notice of defect, the defect will be corrected by EGAT or any third party selected by EGAT at EGAT's discretion, and the cost of the corrections shall be on the responsibility and account of the Contractor.

In the event of an emergency where in the judgement of EGAT the delay resulting from giving formal notice would cause serious loss or damage which could be prevented by immediate action, defects may be corrected by EGAT or a third party chosen by EGAT without giving prior notice to the Contractor, and the cost of the corrections shall be paid by the Contractor. In the event such action is taken by EGAT, the Contractor will be notified promptly and shall assist wherever possible in making the necessary corrections.

F-11. Drawings and Documents to be Furnished by Contractor

EGAT reserves the right to require the Contractor to submit the drawings and documents listed in the tables attached at the end of this Section by the designated dates either by registered airmail for foreign mail and registered mail for local mail and/or by electronic files uploaded via document management system. However, cover letters shall be submitted in hard copy to EGAT.

After the requirement under this Article has been fulfilled by the Contractor, a Drawing and Document Acceptance Certificate will be issued by EGAT to certify the receipt of all required drawings and documents:

a. Drawings

- (1) Drawing Title and Sizes. The title of Contractor's drawing shall also include the followings :

ELECTRICITY GENERATING AUTHORITY OF THAILAND

EGAT's Contract No. _____

Item No. _____

Subs. Name _____

The sizes of the drawings except otherwise specified in the Specification shall be as follows :

<u>Size Designation</u>	<u>Dimensions in MM</u>	<u>Dimensions in Inches</u>
A0	841 x 1,189	(33.11 x 46.81)
A1	594 x 841	(23.39 x 33.11)
A2	420 x 594	(16.54 x 23.39)
A3	297 x 420	(11.69 x 16.54)
A4	210 x 297	(8.27 x 11.69)

- (2) Reference Drawings and Catalogues. General drawings showing principal dimensions and weights of Equipment, including controlling dimensions which affect space and handling requirements.

- (3) Drawings and Data for Approval. The Contractor shall submit for approval checked detail assembly drawings including firm dimensions, foundation details and setting diagrams, physical size and weights of all principal parts, complete operating characteristics and ratings of Equipment, connection and schematic wiring diagrams, descriptive information and any other information sufficient to demonstrate fully that the Equipment to be furnished will conform to the requirements and intent of these Contract Documents.

Schematic diagrams shall indicate the operation and function of all electrical Equipment, accompanied, where necessary, with explanatory notes. Wiring diagrams shall show the external connection required, sufficient for EGAT to complete interconnection cable diagrams.

One print each of the drawings submitted for approval will be returned to the Contractor by EGAT or its authorized representative within thirty (30) Days after receipt at EGAT's office, marked either "Approved",

"Approved Except as Noted", or "Returned for Correction"/"Not Reviewed". The notations "Approved" or "Approved Except as Noted" will authorize the Contractor to proceed with the manufacture of the Equipment covered by such drawing, subject to the correction, if any, indicated thereon. When prints of drawings have been "Returned for Correction"/"Not Reviewed"., the Contractor shall make the necessary revisions on the drawings and shall within thirty (30) Days resubmit drawings for approval in the same manner as before.

Any manufacturing done before approval of the drawings will be at the Contractor's risk. EGAT shall have the right to require the Contractor to make any changes in the design which may be necessary, in the opinion of EGAT, to make the Equipment conform to the requirements and intent of these Contract Documents without additional cost to EGAT. Approval of the Contractor's drawings shall not be held to relieve the Contractor of any part of his obligation to meet all of the requirements of these Contract Documents or of the responsibility for the correctness of his drawings.

- (4) Reproducibles of all final approved drawings shall be made on mylar films.
- b. Report of Shop Test. The Contractor shall furnish certified copies of reports of all tests required of the manufacturer to show compliance with the applicable standards and specifications. The cost of all tests and reports shall be borne by the Contractor.
- c. Instruction Manuals. The Contractor shall furnish complete set of instruction manuals and all final approved drawings (if any) for erection, operation, maintenance and repair of the Equipment, and for identification of parts. The instruction manuals shall be combined, assembled and bound in binders. Each binder cover shall be stamped with proper identification indicating name of Equipment, manufacturer's name and address, EGAT's Contract number, manufacturer's reference, etc.

Prior to the assembly and submittal of the instruction manuals, a proof of the cover lettering and the table of contents shall be submitted in sufficient time for EGAT's acceptance without delaying submittal of the finished manuals.

The CD-ROM (Compact Disc-Read Only Memory) of final drawings, final documents, test report and instruction manual, if required, shall conform to the applicable International Standard Organization 9660 (ISO 9660) and have capacity of approximately 700 Mbytes.

The data in CD-ROM shall be created by the following software :

Drawing

The Contractor shall submit all drawings created by CAD software as follows:

1. MICROSTATION software Version SE or
2. AUTOCAD software Version 2000

Any necessary information supporting the completion of reading files (such as special font etc.) shall be included in CD-ROM.

Documents

The Contractor shall submit all documents in Adobe Portable Document Format File (PDF format) and also Program of Acrobat Reader in order to read the file completely in CD-ROM.

Drawing/Document List

The Contractor shall submit the drawings/documents listing information in work sheets file provided by EGAT in CD-ROM in Microsoft Excel file format.

Drawing list of design drawings, as built drawings, manufacturing drawings shall also be submitted together with the drawings in the CD-ROM.

F-12. Maintenance Security

The Contractor shall provide to EGAT prior to the issuance of the acceptance certificate and as a condition for the release of the payment of the last instalment as specified in Article F-8. Payment, maintenance security(ies) in the amount of ten (10) per cent, round up to the nearest whole number, of the total Contract Price or ten (10) per cent, round up to the nearest whole number, of each schedule, excluding the cost of installation supervisor and cost of test(s), guaranteeing the Contractor's performance of the provision of Article F-10. Maintenance Guarantee. The Contractor shall oblige himself to attend to and replace, during the period of maintenance, all malfunctioning parts and for repair of all defects noted in the Work and communicated to the Contractor in writing by EGAT. In case of extended guarantee of the repaired or replaced Equipment, the Contractor may request for return of the original maintenance security and submit a new maintenance security in the amount of ten (10) per cent, round up to the nearest whole number, of the Contract Price of Equipment under the extended guarantee.

The maintenance security shall be in the form of a cash deposit, or a cashier cheque issued by a local bank, or a bank guarantee or letter of guarantee issued only by a local bank or an acceptable financial institution in Thailand, or by a foreign bank counter-guaranteed by a local bank, and made payable to EGAT in the same currency as that of

the Contract. In case of a cash deposit or a cashier cheque, only Thai baht portion of the Contract Price can be made. EGAT may at its absolute discretion refuse to approve any maintenance security offered or may at any time, upon application by the Contractor, approve of the substitution for any maintenance security held under this Article by other maintenance security on such terms and conditions as may be approved by EGAT.

The conditions of guarantor's obligations in the maintenance security shall include, inter alia; the following :

1. The guarantor shall unconditionally guarantee, as primary obligor and not as surety merely, payment of any obligations, damages, liquidated damages, performance penalties, or expenses for which the Contractor may become liable to EGAT.
2. No extension of time, change in, addition to, or other modification of the terms of the Contract or Work to be performed thereunder, or of the Specifications or other Contract Documents shall in anyway release the guarantor from any liability under the maintenance security, and the guarantor shall thereby waive notice of any such extension of time, change, addition or modification.
3. The maintenance security shall be valid and remain in full effect from the date of acceptance of Work until all obligations on the part of the Contractor under the Contract have been fulfilled.

Unless and until an official receipt is issued in respect to a maintenance security deposit, EGAT will not recognize or accept any such deposit as fulfilling the requirements of this Article. Failure to deposit a maintenance security at the time specified above in this Article or such extended time as may be approved by EGAT shall be a breach of this Contract and EGAT may, at its discretion, retain the payment of the last instalment of the total Contract Price.

If any maintenance security furnished under this Article shall become unacceptable to EGAT, or if any guarantor shall fail to furnish reports as to guarantor's financial condition from time to time, as requested by EGAT, the Contractor shall promptly furnish such additional or alternative maintenance security as may be necessary to satisfy the Contract requirements for a maintenance security.

In the event of any default or breach of this Contract on the part of the Contractor, EGAT may convert into money any maintenance security which does not consist of money, and the proceeds shall be deemed to be a cash deposit under this Article. EGAT shall not be liable for any cost, expenses and/or loss resulting from the conversion of any maintenance security deposit into money as herein provided. The Contractor shall bear the cost of the maintenance security.

The maintenance security, in case of a bank guarantee, or letter of guarantee, shall be in conformity with the following specimen.

SPECIMEN OF MAINTENANCE GUARANTEE

To :

Date :

Electricity Generating Authority of Thailand
Bangkrui, Nonthaburi 11130
Thailand

Re : Maintenance Security for Contract
No. EGAT _____

Gentlemen :

In accordance with the provision of the Contract for _____ No. EGAT _____ dated _____ (hereinafter referred to as the Contract), the contents of which have been noted by us that Messrs. _____ (hereinafter referred to as the Contractor) has to deposit with Electricity Generating Authority of Thailand, (hereinafter referred to as EGAT) a Maintenance Security to guarantee the proper functioning of the _____ of the Contract as specified in Article F-10. Maintenance Guarantee in the amount of _____ (in words : _____) which is ten (10) per cent, round up to the nearest whole number, of the total Contract Price or ten (10) per cent, round up to the nearest whole number, of each schedule of the said Work, excluding the cost of installation supervisor and cost of test(s), we, the _____ as instructed by the Contractor, agree unconditionally to irrevocably guarantee as primary Obligor, the payment to EGAT at its first demand, without whatsoever right of objection on our part and without its first claim with the Contractor giving EGAT the right of claim for penalty, damages, liquidated damages or any expenses for which the Contractor may become liable to EGAT under the Contract.

We further agree that no extension of time, change in, addition to or other modification of terms of the Contract or work to be performed thereunder, or of the Specifications or other Contract Documents, which may be made between EGAT and the Contractor, shall in any way release us from any liability under the Maintenance Security, and we shall thereby waive notice of any such extension of time, change, addition or modification.

This Maintenance Security shall be valid and remain in full effect for a period of _____ (...) Year(s) from the day immediately following the date of the acceptance of Equipment. If necessary, this Maintenance Security shall be extended as specified in Article F-10. Maintenance Guarantee.

Yours very truly,

Authorized Signature

Drawings and Documents to be Furnished by the Contractor
(For All Equipment except Control and Protection Equipment)

The Contractor shall submit by registered mail and/or by electronic files uploaded via document management system with the drawings and other documents listed below by the designated deadlines.

Should EGAT require the Contractor to submit the drawings and documents in electronic files via EGAT's document management system, the Contractor is also required to submit the drawings and documents in Print and CD-ROM at the number of copies listed in the parenthesis below.

Drawings/Documents	No. of copies		Deadline and Remarks
	P	CD-ROM	
Manufacturing and Delivery Schedule	1 (-)	- (-)	Within 60 Days after confirmation of Letter of Award of Contract
Quality Assurance Program (If requested by EGAT)	1 (-)	- (-)	Within 60 Days after confirmation of Letter of Award of Contract
Drawings or Documents "FOR REFERENCE"	4 (2)	- (-)	Within 90 Days after confirmation of Letter of Award of Contract
Drawings or Documents "FOR APPROVAL"	4 (-)	- (-)	Within 60 Days for foundation, steel supporting structure (if any) and within 90 Days for others after confirmation of Letter of Award of Contract
Drawings or Documents "FOR REAPPROVAL"	4 (-)	- (-)	Within 30 Days after receipt of returned approval drawings for correction
Drawings and Documents "FINAL DRAWING or FINAL DOCUMENT"	4 (2) *4 (-)	- (-)	Within 30 Days after receipt of approved drawings
Final Design Data	4 (-)	- (-)	Within 150 Days after confirmation of Letter of Award of Contract
Test Procedure (Factory Test)	1 (-)	- (-)	Within 150 Days after confirmation of Letter of Award of Contract
Test Schedule (Factory Test)	1 (-)	- (-)	Not less than 60 Days before testing for foreign supply Not less than 30 Days before testing for local supply
Test Report (Factory Test)	1 (-)	- (-)	Upon completion of tests
Installation Instruction	9 (7)	5 (5)	60 Days before first shipment/delivery
Instruction Manuals	9 (7)	5 (5)	Before shipment/delivery

Note : P = Print Drawing or Document
CD-ROM = Compact Disc-Read Only Memory with capacity of approximate 700 Mbytes conforming to ISO 9660

*For Transmission Line Insulator, Hardware Assemblies and Line Accessories, Transmission Line Steel Tower, HTLS Transmission Line Conductor and Invar Transmission Line Conductor.

DRAFT

SECTION G
RATINGS AND FEATURES

G. RATINGS AND FEATURES

G -1. Ratings and Features

The following Ratings and Features sheets are attached hereto and made a part of the Contract Documents:

<u>RF No.</u>	<u>Description</u>	<u>Page</u>
RX951A	Shunt Reactor	G2

DRAFT

**Shunt Reactor
Specification No. 731**



**Substation Electrical
Equipment Engineering Department**

Ratings and Features	Designed : via ECM System	Validated : via ECM System	Revision 0	Page 1/1
RF No. RX951A	Verified : via ECM System	Approved : via ECM System	Dated : 12/12/2025	

a. Type / Type of Cooling	3-phase, Oil Filled, Outdoor / ONAN	
b. Rated Frequency	50	Hz
c. Highest Voltage for Equipment	550	kV
d. Rated Voltage	525	kV
e. Rated Power (3-Phase at Rated Voltage)	110	Mvar
f. Winding Voltage Rating		
- Highest Voltage (High Voltage)	550	kV
- Highest Voltage (Neutral)	145	kV
- Lightning Impulse Withstand Voltage (High Voltage)	1,550	kV
- Lightning Impulse Withstand Voltage (Neutral)	650	kV
- Switching Impulse Withstand Voltage (High Voltage)	1,175	kV
g. Bushing Voltage Rating		
- Highest Voltage (High Voltage)	550	kV
- Highest Voltage (Neutral)	145	kV
- Lightning Impulse Withstand Voltage (High Voltage)	1,550	kV
- Lightning Impulse Withstand Voltage (Neutral)	650	kV
- Switching Impulse Withstand Voltage, Wet (High Voltage)	1,175	kV
h. Bushing		
- Material of Insulator	Porcelain	
- Creepage Distance of HV Side	≥ 13,750	mm
- Creepage Distance of Neutral	≥ 3,625	mm
i. Connection	Grounded Wye	
j. Audible Noise Level (Internal noise only without external accessories such as sound panels, sound enclosure, dampers, sound absorbers etc.)	≤ 74	dB(A)
k. X0/X1 Ratio of Phase Reactor	1.0 (Tolerance ±2%)	
l. Temperature Class of Winding Insulation	120	
m. Winding Temperature Rise (Continuous at 105% Rated Voltage and Rated Frequency)		
- Average / Hottest Spot	≤ 60 / ≤ 75	°C
n. Current Transformer		
High Voltage Terminal		
- Qty. per Phase	3	
- Accuracy Class	5P20, 20 VA	
- Continuous Thermal Current Rating Factor	1.0	
- Ratio	400/600 : 1 A	
Neutral Terminal		
- Qty. per Phase	2	
- Accuracy Class	5P20, 20 VA	
- Continuous Thermal Current Rating Factor	1.0	
- Ratio	400/600 : 1 A	
o. Max. Permissible Shipping Weight	150 tons	
p. Max. Permissible Shipping Dimension (W × L × H)	4.0 m × 10.0 m × 4.0 m (See Note 1)	
q. Applicable Standard	IEC 60076-6	

- Note : 1. Exception to the weight and dimension limitation stated in Article : Clearance and Weight Limitations of Section E : General Conditions of Contract.
2. Radiators shall be designed to be attached to the reactor tank. The radiator bank located on separated foundation from the reactor foundation is not acceptable.

DRAFT

**SECTION I
SPECIFICATIONS**

I. SPECIFICATIONS

I-1. Specifications

The following specifications are attached hereto and made a part of the Contract Documents :

<u>Specification No.</u>	<u>Description</u>	<u>Page</u>
731 (June 2025)	Shunt Reactor and Neutral Reactor	731.1 – 731.50

Specification No 731

Shunt Reactor and Neutral Reactor

731-1 General. This specification covers the general requirements for design, manufactures, test and supply of the shunt reactor and neutral reactor. Requirements for a neutral reactor may be required in addition to the shunt reactor in order to reduce the secondary arc current and facilitate high speed single pole reclosing of the transmission line.

The specific ratings, characteristics and the special requirements and features of the reactor not cover herein are given in the accompanying Ratings and Features sheet.

731-2 Materials and Workmanship. All materials supplied under this specification shall be new and shall be the best available for the purposes used, considering strength, ductility, durability, electrical characteristics, aging, failure rate and suitability for the intended service and best engineering practice. Workmanship shall be of the highest grade and in accordance with the best modern standard practice.

731-3 Service Conditions. All materials shall be suitable for installation and used at an altitude of 1000 m or less in a tropical climate with a maximum ambient temperature of 45°C, maximum 24-hour average temperature of 40°C, yearly average temperature of 30°C and 100% relative humidity without corrosion, deterioration or degradation of performance characteristics.

731-4 Codes and Standards. All equipment, materials, devices, fabrication and testing shall conform to the codes, specifications and standards listed below and all applicable codes, specifications and standard referenced therein.

ANSI	American National Standards Institute
ASME	American Society of Mechanical Engineers
ASTM	American Society for Testing and Materials
AWS	American Welding Society
IEC	The International Electrotechnical Commission
IEEE	The Institute of Electrical and Electronics Engineers
NEMA	National Electric Manufacturers Association

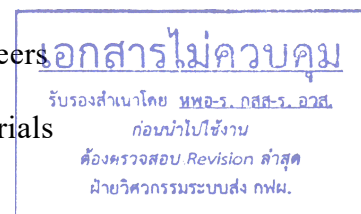

17 กุมภาพันธ์ 2569

Sotavijit Hirinrom

All threaded parts requiring external connection shall have metric screw and pipe threads. All internal parts may have threads in accordance with the established specification in the country of manufacturer.

It is the intent that all equipment, materials, devices, fabrication and testing shall conform to the application codes, specifications and standards even though there are not specifically noted herein. Equivalent codes, specifications and standards established and approved in the country of equipment or material manufacturer may be used subject to EGAT's approval. If this election is made, the Bidder shall so state and include in his bid the governing codes, specifications, and standards proposed together with an itemized list of specific deviations from the requirements of codes, specifications and standards referenced herein.

The latest issue of all codes, specifications and standards shall govern.

The most stringent requirement, in the event of code, specification or standard conflict, shall govern. This specification shall govern in the event of discrepancies between it and applicable codes, specifications and standards.

731-5 Working Stresses - The design of all components, particularly those subject to shock or stress reversal, shall incorporate reasonable factors of safety in all cases.

731-6 Reactor Requirements. The shunt and neutral reactor required shall meet the requirements described herein and in the Ratings and Features sheet.

Winding conductor shall be free from burrs, scale and splinters and shall be uniformly insulated. In every case, each conductor strand shall be insulated by varnish to avoid the risk of sulfur attack in contact with insulating oil. Bare conductor (without the enamel) is not acceptable.

All insulation shall be of uniform quality and void free. Current carrying joints or splices shall be welded or braced, properly formed and finished and insulated for the basic insulation level.

731-6.1 Shunt Reactor.

For three phase shunt reactor, The reactor shall be furnished utilizing a three-phase design, placing all three phases within a single tank. The neutral side of the main winding for each phase shall be brought out of the tank through an insulating bushing. The neutral connection shall be made externally.

For single phase shunt reactor, The neutral side of the main winding shall be brought out of the tank through an insulating bushing. The neutral connection shall be made externally.

Sotakajit Hirinon

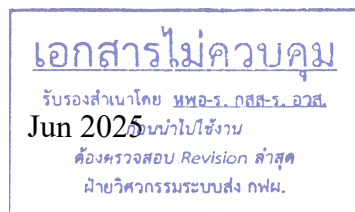

731-6.2 Neutral Reactor. A neutral reactor shall also be furnished when it is required for use with the shunt reactor to facilitate high speed single pole reclosing of the transmission line and reduce the secondary arc current.

731-6.3 Impedance Characteristic. The shunt and neutral reactors shall be furnished with the impedance characteristics described below. Impedance characteristic curves shall be furnished for each reactor.

6.3.1 Tolerance. The reactance tolerance shall be within $\pm 5\%$ of the specified value.

6.3.2 Shunt Reactor Tolerance Between Phases. The reactance of any one phase shall be within $\pm 2\%$ of the average reactance of the three phases.

6.3.3 Shunt Reactor Linearity. The reactance characteristic of the shunt reactor shall be linear with up to 125% of rated voltage applied.

The slope of the reactance characteristic with 125% to 150% of rated voltage applied shall not be less than one third that with zero to 125 % of rated voltage applied.

6.3.4 Shunt Reactor Zero Sequence Reactance. The ratio of the zero sequence reactance to the positive sequence reactance of the shunt reactor (X_0/X_1) shall be within the range specified in the Ratings and Features sheet in order to permit successful single pole reclosing of the power circuit breakers.

6.3.5 Neutral Reactor Impedance. The impedance of the neutral reactor shall be linear for voltages from zero to the 10s short time overvoltage rating of 1.4 x rated voltage applied. The neutral reactor impedance is dependent on the impedance and the X_0/X_1 ratio of the shunt reactor. After the manufacturer has determined the X_0/X_1 ratio of the shunt reactor, the impedance of the neutral reactor shall be selected as specified in the Ratings and Features sheet.

731-6.4 Tank. Each reactor shall be provided with a steel case of substantial construction and a welded main cover. The tank shall be capable of withstanding, without leakage or permanent distortion of an internal gas pressure of 1 kg/cm² (14.22 lb/in²) and a vacuum of 760 mm of mercury and shall be designed and constructed for full vacuum filling in the field. The maximum design positive and negative operating pressures shall be indicated on the nameplate. All valves, fittings and piping shall

Sotrasidh Hmamm

เอกสารไม่ควบคุม
Jun 2025
ต้องตรวจสอบ Revision ล่าสุด
ฝ่ายวิศวกรรมระบบส่ง กฟผ.

be designed and constructed for such vacuum filling. The tank cover shall not be designed to retain water.

The tank shall also have suitable jacking pads, pulling eyes and lifting lugs. All the jacking pads, pulling eyes and skid base shall be designed and constructed for possibly moving the complete assembly reactor on roller in either direction. The jacking pads shall be located at the tank side wall of at least 40 cm above reactor base and shall be suitable for EGAT's jack having base dimension of 30 cm x 25 cm in rectangular. The jacking pads and lifting lugs shall be welded on longer tank sides. The tank shall be provided with a fabricated structural steel skid base to allow skidding or moving on roller in either direction. The tank shall have four (4) jacking pads for applying force at the same time. The base and skids for shunt reactor shall be fabricated as one piece with the distance between skids shall be in the range of 100 to 150 cm (center to center). A flat base plate is not acceptable for shunt reactor.

The position of center of gravity for reactor under transportation condition and complete assembly condition shall be clearly marked on the reactor tank, the axes of center of gravity for both conditions shall be marked at skid base of all four sides of reactor. The distance between center of gravity under transportation condition and the center line of reactor shall not be more than 150 mm.

731-6.5 Sound Enclosure. Each sound enclosure, if required, shall be outdoor and waterproof. Outside shall be of steel plate and frame with anti-corrosion painted. Sound absorbing materials can be used inside of the sound enclosure for additional attenuation. Necessary ventilation (intake and outlet ducts, cooling fans, etc.) can be provided to prevent heat dissipation of the sound enclosure.

Specific layout, accessories, test details and other requirements not cover herein are given in the accompanying Ratings and Features sheet.

731-6.6 Winding Temperature Rise. The shunt and neutral reactors, with sound enclosure (if required), shall be furnished with the temperature rise limits of 60°C for the winding temperature by resistance and 75°C for the hottest spot winding temperature rise over ambient temperature. The reactors shall be designed to meet the winding temperature rise limits for continuous operation with maximum operating voltage and rated frequency applied and when subjected to the specified over excitation conditions.

Sotakid Hmimom

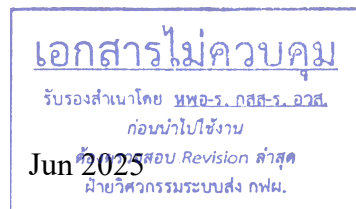

731-6.7 Cooling. The shunt and neutral reactors shall be air cooled, oil-immersed type. The temperature rise requirements shall be met with self-cooling (class ONAN) operation.

731-6.8 Oil System. The shunt and neutral reactors shall be oil immersed with a conservator type oil preservation system. The conservator, radiators and main tank shall each be furnished with their own filling, draining and filtering devices.

6.8.1 Conservator. A rubber bag type conservator shall be furnished to prevent direct contact between the outside air and the oil inside the reactor conservator. The conservator shall be capable of withstanding without leakage or distortion an internal pressure of 1 kg/cm² and a vacuum of 760 mm of mercury. The tank design and construction shall permit field vacuum filling.

The conservator shall be equipped with the devices as follows:

- a. Combination of oil fill, oil filter and vacuum valve.
- b. Oil drain valve with flange connection complete with blank cover plate and gasket.
- c. Dehydrating breather assembly to absorb moisture and remove contaminants from the air which is drawn into the conservator air space. A desiccant shall be used which changes color as it absorbs moisture and can be viewed through a glass window. The breather and valve shall be located close to ground level for ease in maintenance. The silica gel shall be nontoxic type.
- d. Isolation valve between the main tank oil and the conservator oil permitting isolation of the conservator from the main tank.
- e. Liquid level gauge that can be viewed from ground level. Alarm contacts shall be furnished for annunciation.
- f. Air detector relay with alarm contact outputs that can be used to provide an alarm in the event of rubber bag failure if air is allowed to come into contact with the conservator oil.
- g. Lifting eyes for installation and removal.
- h. Connecting valve between air part and oil part of main conservator for evacuation.

6.8.2 Radiators. Radiators shall be furnished consisting of input and output headers and individual cooling units. Machined faced, drilled flanges shall be welded to the main tank, headers and radiator cooling units. These flanges shall be designed for making bolted, gasket connections between units. The cooling units shall be of corrosion resistant metal and shall be designed to permit individual replacement. Indicating shut-off valves shall be provided at each reactor inlet and outlet connection to permit removal of any radiator without de-energizing the reactor. Each radiator shall be furnished with a flanged oil drain valve, and a combination of vacuum-bleeder valve and lifting eyes. The radiators shall be designed and constructed for independent vacuum filling in the field. Each radiator shall be of galvanized with painted.

6.8.3 Pressure Relief Device. A self-reset type pressure relief device shall be provided to prevent excessive pressures from building up inside the tank which could cause equipment damage. The pressure relief device shall automatically reset following an operation and shall be furnished with a semaphore or other visible indicator of an operation of the device, visible from ground level. It shall have trip contacts to provide indication of an operation of the device. Degree of Protection shall be IP65.

6.8.4 Insulating Oil. The property of the insulating oil shall be accordance with EGAT's SPECIFICATION OF MINERAL INSULATING OIL. The insulating oil furnished for filling at site shall be compatible with the oil remaining on the core and coils after factory testing of the reactor and the amount furnished shall be sufficient for actual filling all reactor. The Contractor shall furnish EGAT at least 1% of oil quantity for field application as required. The oil shall be shipped in non-returnable steel drums which shall become the property of EGAT.

Specification of insulating oil used shall be furnished with the reactor. The certified test report shall also be submitted and attached to the reactor test report.

6.8.5 Oil Temperature. The top-oil temperature rise measured at the top of the main tank shall not exceed 60°C over ambient temperature.

731-6.9 Gas Venting. Piping shall be arranged to have a slope of not less than 0.05 radians (2.86 degrees) from the horizontal and shall be upward toward the conservator. The highest point of every pocket in the tank and attachments in which gas may accumulate

-731.6-

Sotralid Hirinon

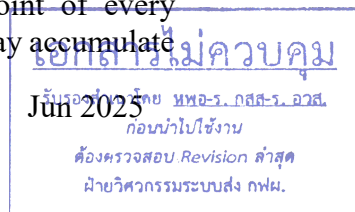

shall be connected together by piping and shall be connected through the buchholz relay. Valves with flange shall be provided for both sides of relay.

731-6.10 Overexcitation. The shunt and neutral reactors shall withstand the overexcitation requirements listed below without exceeding the specified permissible temperature rises.

- a) Maximum operating voltage at 50 Hz, continuously.
- b) 1.25 x rated voltage at 50 Hz, for 60 s.
- c) 1.40 x rated voltage at 50 Hz, for 10 s.
- d) 1.00 x rated voltage at 48Hz, continuously.

731-6.11 Noise and Vibration. The reactor and its accessories (including sound enclosure, if required.) shall be designed, manufactured and assembled so as to minimize and withstand without damage the inherent vibration that occurs during transportation. Neither shipping vibration nor vibration occurring during normal operation shall reduce the expected life of the reactor assemblies. The natural frequency of the reactor shall be recorded in the test reports. The third harmonic component of the reactor current shall not exceed three percent of the fundamental when the reactor is energized at rated voltage with a sinusoidal wave form.

- a. An additional consideration shall be the relation of levels of tank stress and vibration to temperature. The tank shall be constructed to withstand any mechanical stress leading to fatigue fracture resulting from operation between expected minimum and maximum ambient.
- b. Tank construction shall be such that strain gauges may be mounted on or connected to the magnetic circuits with leads being brought out to external housings, so that vibrations may be measured at selected positions on the reactor tank or cover utilizing the strain gauges attached thereto.
- c. The peak-to-peak vibration amplitude shall not exceed 100 microns as measured at any point on the tank walls or cover, or 30 microns at any point on the tank bottom, while the reactor is operating at maximum rated voltage.
- d. The vibrational stresses at any point on the tank walls or cover, based on actual measurements or calculations, shall not exceed 2800 psi (20,000 kPa).

Sotajid Hmimom

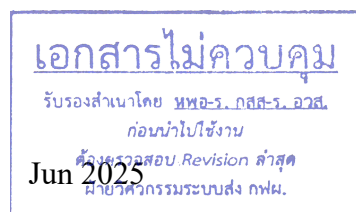

- e. Reactor noise level with all auxiliaries in operation shall not exceed the values specified in the Ratings and Features sheet when tested in accordance with IEC 60076-6.

731-6.12 Short Circuit Capability. The neutral reactor shall be designed and constructed to withstand the mechanical stress produced by external short circuit. The short circuit current shall be according to IEC 60076-6.

731-6.13 Bushings. All bushings shall be resin-impregnated paper-insulated bushing for capacitance graded bushing and solid for non-capacitance graded bushing. For resin-impregnated paper-insulated bushing, the inner space between insulator and condenser body, if any, must not be filled with oil or gas. The material, electrical and mechanical characteristics shall comply with the applicable requirements of the latest IEC 60137.

All porcelain used in bushing shall be wet process, homogeneous, and free from cavities or other flaws. The glazing shall be uniform in color and free from blisters, burns and other defects. The color of all porcelain insulators shall be chocolate brown. All porcelain parts of 230 kV and below bushing shall be one piece. The porcelain housing for 69 kV and above bushing shall be cemented to the flange.

All bushings shall be mounted so that their installation and removal may be accomplished without draining the oil below the top of the windings. The phase spacing between any bushings shall not be less than 800 mm.

For Single Phase Shunt Reactor;

The arrangement of the bushings on the reactor shall be located as shown on the drawing of "Layout for installation of Single Phase Shunt Reactor" attached. The neutral bushing shall be arranged for vertical take-off. The neutral bushings shall be top cover mounted.

For Three Phase Shunt Reactor;

The bushings shall be located in such a way that when facing against the high voltage side of the reactor, H₁ bushing shall be on the right-hand side, followed by H₂ and H₃ toward the left-hand side respectively. H₀₁, H₀₂, H₀₃ bushings of the neutral side shall be directly opposite H₁, H₂, H₃ bushings respectively. The arrangement of the bushings on the reactor shall be located as shown on the drawing of "Bushing Location for Three Phase Shunt Reactor" attached.

Sotakid Hmimom

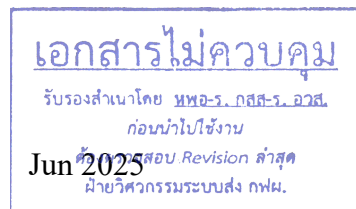

Package for Long Term Storage Bushing; (For Resin Impregnated Paper (RIP) Condenser bushing)

All bushings shall be packed in the long-term storage bushing (at least 24 months) by the instruction manual. The manual shall be submitted together with the tender document during the bidding.

731-6.14 Terminal Pad. Each equipment terminal for connecting to the line or other equipment shall be equipped with a suitable terminal pad unless otherwise specified. The terminal pad shall be provided with 14.3 mm (9/16 inch) diameter holes with a 45 mm (1-3/4 inch) spacing between the centers of each hole in accordance with the NEMA Standards CC1, 4 holes arrangement for 230 kV and below and 6 holes (2×3 bolt holes pattern) arrangement for 500 kV.

The terminal pad shall be of high conductivity copper or aluminum alloy and, unless it is made of aluminum alloy, shall be plated with hot flow electro-tinned to a thickness of not less than 0.0127 mm (0.0005 inch).

The terminal pad on the shunt reactor middle neutral bushing shall be suitable for accepting three NEMA standards 4 holes pad terminal connectors (for making connections between neutral bushings and ground or a neutral reactor).

731-7 Control Cabinet. The shunt and neutral reactor shall be furnished complete with a tank mounted control cabinet. In case of the sound enclosure is required, the control cabinet shall be mounted on the sound enclosure. The control cabinet shall house terminal blocks, annunciator, auxiliary relays and other auxiliary devices. The control cabinet shall be weatherproof, rigidly framed and fabricated for 3 mm minimum thickness steel sheet.

731-7.1 Type. The control cabinet shall be of the dead front type with gasketed, vertically hinged and adequately braced front door(s). The doors shall have a latching handle complete with a key lock and key cover and shall be 180 degree opening, complete with a latching device to secure the door(s) in the fully open position. Center opening double doors shall be provided where the door width exceeds 760 mm. Double door cabinets shall not have latching or bracing devices between the doors that would prevent easy access to the enclosure interior.

The interior of the front door of reactor control cabinet and common control cabinet, in case of single-phase shunt reactor, shall be provided with a holder suitable for the storage of one complete set of reactor drawings and instruction books. The cabinets shall have baffled louvers complete with insect screens.

Sotajid Hirinam

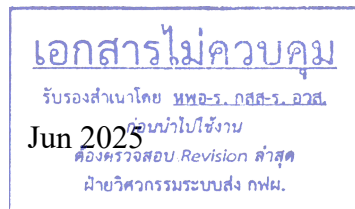

The control cabinet shall be mounted at an elevation such that control and selector switches, lockout relays and pushbuttons are located approximately 1.0 m above the level at which a person will stand when operating these devices. All cabinet installed control and selector switches and push buttons shall be dead-front mounted.

Each control cabinet shall be provided with a gasket removable plate at the bottom for field conduit, armoured cable or cable tray drilling. The bottom of the control terminal cabinet shall be equipped with removable blank cover plate suitable for equipment above. If it is conduit, four (4) 88.9 mm diameter knock out type holes suitable for 3 inches rigid steel conduit shall be provided.

For Single Phase Shunt Reactor

A separate mounted shunt reactor bank common control cabinet complete with supporting frame or members for installation on the shunt reactor bank center phase foundation shall be furnished. This cabinet shall house all shunt reactor bank common control and indication devices and accessories including, but not limited to, air circuit breakers, relays, and the common shunt reactor annunciator, all as described herein; and auxiliary tripping and alarm relays.

All galvanized bolts, nuts and washers, including foundation anchor bolts, required for complete assembly and erection of the common control cabinet shall be furnished.

For common control cabinet, terminal blocks shall be arranged by shunt reactor phase (i.e. phase A-B-C) from left to right or from top to bottom when viewing the terminal blocks.

731-7.2 Wiring. All wiring for control power supply and for remote control, indication, alarm and tripping shall be connected to terminal blocks provided in this cabinet. All wiring shall be tin coated copper conductor, stranded, minimum voltage classification of 600 V with high temperature PVC insulation. Hinge wire shall be extra flexible Class K stranding.

All wiring shall be not less than 2.5 mm², except that all current transformer secondary winding wiring shall be not less than 6 mm² for secondary current 5 A and 4 mm² for secondary current 1 A. All alarms, contacts and control and indication devices shall be completely wired.

Every point of terminal block and wire shall be assigned a designation, with identical designation on each corresponding terminal block and wire as following format:

-731.10-

Sotrajit Himmaman

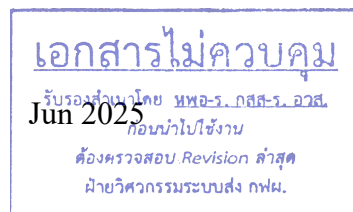

The designation on each wiring end shall consist of both origin and destination designations which separated by '/' symbol. The origin designation shall always be indicated on the side adjacent to where the wiring is terminated while the far side shall always indicate the destination designation of the wiring. Depending on the arrangement of terminal block, device and wiring, wire designation on both ends of the same wiring may be different.

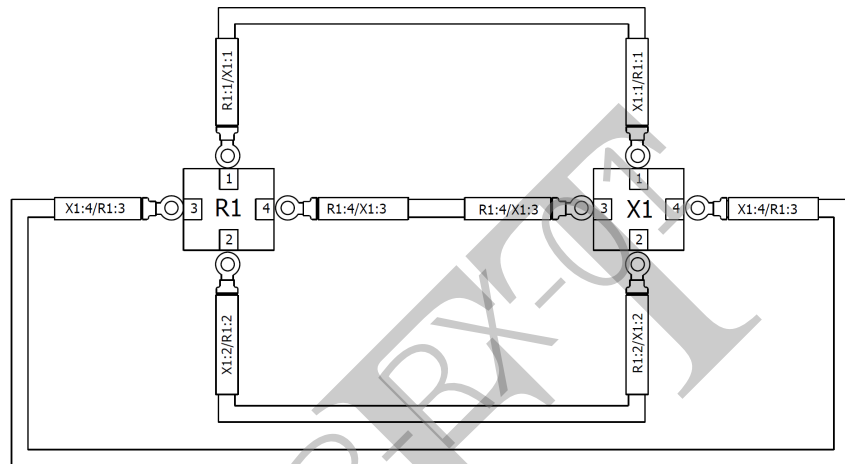

- The letter direction of wire mark shall be read from left to right (for horizontal wiring) and bottom to top (for vertical wiring).
- The terminal number of terminal block shall be arranged from top to bottom and left to right.

This same designation shall also be indicated in the schematic and wiring diagrams. As a rule, a designation will not change until the wire is terminated or connected to other equipment. All wiring shall be designated at both ends by printing on wire designation sleeves. Wire designation shall be by permanent method unaffected by heat, solvents, or steam, and not easily dislodge. Approximately 20% of spare wire designation sleeve shall be furnished. Adhesive labels shall not be acceptable.

Insulated ring tongue crimp type terminal shall be used for current transformer. Insulated ring tongue, ferrule, or cord-end crimp type terminals shall be used for other device and terminal block wire connections.

Within the control cabinet shall be mounted a terminal board to facilitate completing the wiring to external circuits. A barrier shall be provided in the terminal cabinet to separate the 400V circuits and their control from lower voltage circuits. Splices or tee connection shall not be permitted for wiring connection in control cabinet.

The terminal board shall consist of terminal blocks of 600 V molded block type with insulating barrier between terminals.

Both ends of the low voltage wires shall be terminated by compression type terminal lugs. The interior wiring shall be terminated to the terminal block. Each terminal block shall have marking strip, and shall be equipped with the compression type terminal lugs for 4 mm² or larger cable to make connection with outgoing cables. The terminal blocks shall be provided with ten (10) percent but not less than ten (10) additional terminals as spares besides the necessary number. Two (2) or more external wires shall not be connected in one (1) terminal.

Terminal block connections shall be arranged for a maximum of one external wire connection per point. Terminal blocks for external wiring shall have the size suitable for termination of the following cables:

For AC supply	: 2x35 mm ²
For DC supply	: 2x6 mm ²
For CT leads	
- Secondary current 5 A	: 2x6 mm ²
- Secondary current 1 A	: 2x4 mm ²
For others and spares	: 2x4 mm ²

The terminal blocks for AC circuit and the terminal blocks for DC circuit shall be separately grouped as well as the AC terminal blocks shall be covered with transparent plastic box.

All EGAT external alarm, control, indication and control power connections, except as indicated herein, will terminate in this control cabinet. The turn-key Contractor shall be responsible for all interconnections between the individual reactor control cabinets and the common control cabinet. For a supply Contract, EGAT shall be responsible for these external connections. In all cases, the sufficient quantity of cable completed with metallic cable tray for interconnections between individual reactor control cabinet and common control cabinet, drawings showing all cabinet interconnections shall be provided by reactor manufacturer. Each external wire shall be identified at each end with a metallic cable tag placed over the armoured cable or cable tray.

The Contractor shall furnish and install where practicable armoured cable or cable tray for wiring all control, protective accessories and bushing current transformers. Short sections of flexible, waterproof conduit may be used for shock mounting. The armoured cable or cable tray shall be suitable connected to the reactor accessories and bushing current transformers and shall be connected to a control cabinet upon each shunt reactor tank.

Sotakajit Himmam

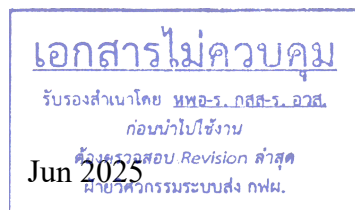

A minimum clearance of 125 mm shall be provided between terminal blocks to facilitate wiring.

731-7.3 Copper Ground Bus. A 25 mm wide x 6 mm thick or 30 mm wide x 5 mm thick copper ground bus with 4 mm drilled and tapped holes shall be provided with insulation support bushing and properly installed to the enclosure near the bottom of each control cabinet for current transformer secondary and control cable shield grounding. The holes shall be spaced on 20 mm center-lines minimum. A 10 mm long binding head screw or screw with bronze spring washer shall be provided in each hole. The ground bus shall have a minimum of ten (10) holes and screws for control cable shields and shall be solidly connected to ground terminal connector located outside of the cabinet. EGAT shall have the option of specifying additional ground bus holes and screws at the time of drawing approval without additional cost to EGAT. The ground terminal connector shall be clamp type suitable for No 4/0 AWG copper stranded conductor which is directly connected to grounding system and provided at one end of each cabinet ground bus.

731-7.4 Space heater, Lighting and Outlet Sufficient space heater and lighting with door control switch shall be provided in the control cabinet. The space heater circuit shall be as follows:

- a) A set of space heater is operated continuously to maintain the temperature rise inside the cabinet within 5°C above the ambient temperature.
- b) A set of space heater is operated with temperature supervised humidity control.

A space heater with temperature supervised humidity control shall be provided in each control cabinet and connected to the 230 V, 50 Hz single-phase power supply. The heaters shall be located to promote warm air circulation to prevent cabinet interior condensation while avoiding insulating material and other component accelerated deterioration.

Lighting, completed with control switch and two sets of 20 A, 250 V, two pole three wire grounding device universal outlets for connection to the EGAT furnished single phase alternating current supply, shall be furnished and installed in each control cabinet.

731-8 Control and Protection Schematic Diagram

731-8.1 AC-DC Circuit Arrangement. EGAT shall provide 400/230 Vac, 50 Hz and 125 Vdc for auxiliary power supply. The Contractor shall furnish and install, where feasible, armoured

cable or cable tray for all wiring as required. Short sections of flexible, waterproof conduit may be used for shock mounting. The Contractor shall arrange the schematic of AC and DC circuits as follows:

- a) Disconnecting means shall be provided for possible connection or disconnection of AC and DC circuits to or from EGAT's AC and DC supply.
- b) Circuit breakers of suitable interrupting rating but not less than 5 kA shall be provided for each branch of any AC or DC circuit. Contacts of all circuit breakers shall be operated by both manual and automatic trip.

Circuit breakers shall be furnished at least as follows:

- a) Common control cabinet (For Single phase reactor)
 1. Annunciator loss of DC supply indication AC supply circuit
 2. Annunciator DC supply circuit
 3. Auxiliary tripping and lockout relay DC supply circuit
 4. Reactor bank common AC main control circuit
 5. Reactor bank common AC branch control circuits as required
 6. Other reactor bank common DC branch control circuits as required

- b) Each reactor control cabinet

1. Annunciator loss of DC supply indication AC supply circuit
2. Annunciator DC supply circuit
3. Auxiliary tripping and lockout relay DC supply circuit (For Three phase shunt reactor)
4. Other AC branch control circuits as required
5. Other DC branch control circuits as required

8.1.1 DC Circuit Arrangement Each shunt and neutral reactor control cabinet shall be furnished with a DC circuit arrangement as described below.

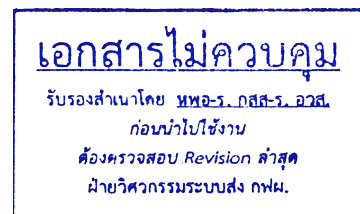

Sotajid Hirinam

17 กุมภาพันธ์ 2569

- a. A DC undervoltage relay with adjustable both operating time and operating voltage shall be provided to detect loss of DC supply voltage to the reactor and shall be located on the circuit side of the disconnect switch. The undervoltage relay shall be furnished with normally closed contacts which shall close on loss of DC to energize an AC relay. This AC relay shall energize the local annunciator "LOSS OF DC SUPPLY" point. The AC relay shall be located in the reactor AC supply circuit and shall provide local and remote indication of loss of DC.
- b. Branch circuits shall be provided for reactor protection and for reactor annunciator control.
- c. A DC circuit shall be provided as described above for energizing the local annunciator "LOSS OF AC SUPPLY" and "LOSS OF AC CONTROL PWR" points and for providing two electrically separate remote indication contacts per point. These annunciator points shall only reset when a reset pushbutton is operated and the AC voltage returns to normal.
- d. The breaker position indicating contact on the annunciator circuit breaker shall energize an AC relay. This AC relay shall energize the local annunciation for "LOSS OF DC CONTROL PWR" point and provide remote contacts for remote indication and the sequence of events recorder.

8.1.2 AC Circuit Arrangement. Each shunt and neutral reactor control cabinet shall be furnished with an AC circuit arrangement as described below.

- a. An AC undervoltage relay with adjustable both operating time and operating voltage shall be provided to detect loss of AC supply voltage to the reactor and shall be located on the circuit side of the disconnect switch. The AC undervoltage relay shall energize the local annunciator "LOSS OF AC SUPPLY" point.
- b. Branch circuits shall be provided for reactor protection and for reactor annunciator control.
- c. An AC circuit shall be provided as described above for energizing the local annunciator "LOSS OF DC SUPPLY" and "LOSS OF DC CONTROL PWR" points and for providing two electrically separate remote indication contacts per point. These annunciator points shall only reset when a reset pushbutton is operated and the DC voltage returns to normal.
- d. The breaker position indicating contact on the annunciator circuit breaker shall energize a DC relay. This DC relay shall energize the local annunciation for "LOSS OF AC CONTROL

Sotajid Hirinam

<p>เอกสารไม่ควบคุม</p> <p>Jun 2025</p> <p>ต้องตรวจสอบ.Revision ล่าสุด ฝ่ายวิศวกรรมระบบส่ง กฟผ.</p>

PWR" point and provide remote contacts for remote indication and the sequence of events recorder.

731-8.2 Auxiliary Tripping and Lockout Relay. The auxiliary tripping and lockout relays, high speed, with the total operating time, including bouncing time of each relay, when the trouble is occurred until the lock out relay is operated shall not be more than 20 ms, shall be furnished for use in the reactor protection scheme. The lockout relay shall be of the mechanically latched-in type and shall be a manually reset device operable by means of a red oval handle. The relay shall be rated for 125 Vdc and operated correctly with 70-140 Vdc applied. A target shall be provided to indicate what position the lockout relay is in. The relay shall be rated to withstand seismic ZPA forces of 10g with input motions between 4 and 16 Hz and 4g with input motions above 33 Hz, when tested according to IEEE standards IEEE C37.98 and IEEE Std 344. No mis-operations shall occur. The insulation shall be rated for 100 megaohms when tested with a 500 Vdc tester for one minute. The lockout relay shall be rated for a dielectric withstand of 1500 V for one minute as specified in IEEE C37.90. The lockout relay shall also be capable of meeting the IEEE C37.90 surge withstand capability tests. The lockout relay shall be furnished with 10 electrically separate normally close contacts and 20 electrically separate normally open contacts in only one lockout relay. The contacts shall be rated to carry 30 A for 3 s, 5 A continuous, and be capable of interrupting 2 of inductive current ($L/R \leq 40$ ms) in a 125 Vdc control circuit. The contact resistance shall have a test value of less than 10 milliohms and be rated for at least 10,000 operations. The contacts shall be easily convertible in the field to normally open or normally closed contacts. The lockout relay shall be provided and located in reactor control cabinet (for three phase shunt reactor) and in common control cabinet (for single phase shunt reactor). These contacts shall be used for tripping and lockout open circuit breakers for reactor faults. The 86RACO "NORMAL-OFF" cut-off selector switch with 10 electrically separate contacts of 10 A continuous current rating shall also be provided and located in shunt reactor control cabinet (for three phase shunt reactor) and in common control cabinet (for single phase shunt reactor).

For any trouble which requires tripping order, the contact of the corresponding shunt reactor protective relays shall be connection to

- a) Directly initiate the auxiliary tripping and lockout relay through the series auxiliary current operating relay with holding coil for annunciator.

Or

Sotajid Hm...

-731.16-

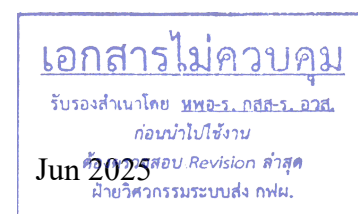

- b) Initiate high speed auxiliary voltage relay (operating time not more than 5 ms), self reset, DC voltage continuously operated type. Each high speed auxiliary voltage relay shall have at least 3 electrically separate normally open contacts, one contact for annunciator, one contact for Remote Terminal Unit (RTU), one contact for Fault Recording System (FRS) (only in case of single phase shunt reactor) and one contact for initiation of auxiliary tripping and lockout relay. Each contact shall withstand at least 5 A, 125 Vdc at continuously duty.

The schematic diagram for tripping circuit shall be as shown on typical drawing No RX-TSD-01 attached.

731-8.3 Annunciator. A lamp type annunciator shall be furnished and installed within the control cabinet of the shunt and neutral reactors. The annunciator shall indicate the reactor trouble described below.

The annunciator window shall be red in case of trip and winding temperature alarm stage 2, white in case of alarm. Transparent window shall be arranged in order that all individual trouble indicated on the annunciator panel can be visualized without opening the control cabinet cover.

Four (4) spare points of annunciator completed with annunciator circuit shall be provided in addition to the annunciators required. Each indication on nameplate shall be made of white translucent material, with black indicated letters. When any trouble contact is closed, the corresponding auxiliary relay of at least two independent contacts, one for signal lamp on annunciator panel and the other for remote indication, shall be energized and selfheld which shall be reset, only if fault has already cleared, by the reset push button provided by the Contractor. Separate terminals shall be provided for each contact for remote indication. Each remote contact shall be wired to separate annunciator terminals. One remote indication contact shall be paralleled with other alarm points to provide a common remote alarm and one remote contact shall be provided for wiring to the substation sequence of events recorder.

The lamp test push button shall also be provided. Both reset and lamp test push button shall be mounted on the same panel of annunciator panel. If there are more than one fault occurs simultaneously, annunciators shall be annunciated correctly and only a fault that has cleared can be reset with the reset push button.

Sotakid Hmimom

<p>เอกสารไม่ควบคุม</p> <p>รับรองสำเนาโดย นพอ.ร. กสส.ร. อวส.</p> <p>ก่อนนำไปใช้งาน</p> <p>ตรวจสอบล่าสุด</p> <p>Jun 2025</p> <p>ฝ่ายวิศวกรรมระบบส่ง กฟผ.</p>
--

The tripping circuit part shall be independent from the annunciator circuit part in order that tripping is still possible while annunciator circuit is off. Diodes and integrated circuit components are not allowed for tripping and annunciating circuits.

The contacts of all relay, gauges, and thermometers shall be insulated from ground and shall be of a positive, snap action or mercury type. All alarm and trip contacts shall be suitable for operation on 125 Vdc.

The annunciator control voltage shall be 125 Vdc. The control voltage for LOSS OF DC SUPPLY indication shall be 230V, 50 Hz single-phase.

For Single Phase Shunt Reactor;

When a shunt reactor or bank trouble condition occurs, the corresponding annunciator window shall be illuminated and two electrically separate contacts for remote indication shall close. The window shall remain illuminated and the remote indication contacts shall remain close until the reset push button is operated and the trouble is cleared. Each remote indication contact shall be wired to separate annunciator terminals.

One remote indication contacts of each shunt reactor annunciator point shall be paralleled and wired to an associated common alarm point on the common control cabinet annunciator via terminal block points in the shunt reactor control cabinet and in the common control cabinet. The other remote indication contacts, each shall be wired to separated terminal block points in the common control cabinet via terminal block points in the shunt reactor control cabinet for connection by EGAT to RTU.

For remote indication contacts of the common control cabinet annunciator, each contact shall be wired to separated terminal block point in the common control cabinet for connection by EGAT to RTU.

For those trouble conditions requiring both circuit breaker tripping and annunciation, the trouble contact shall trip the circuit breaker via the shunt reactor auxiliary tripping and lockout relay. Therefore, a high-speed auxiliary relay with electric latch connected in series with the trouble contact shall be furnished. One contact of the latter relay shall be connected to actuate the annunciator. Two contacts of the latter relay shall be wired to common control cabinet separated terminal block points via shunt reactor control cabinet terminal block points for connection to RTU and FRS.

Sotakidh Hm...

เอกสารไม่ควบคุม
Jun 2025
ต้องตรวจสอบ.Revision ล่าสุด
ฝ่ายวิศวกรรมระบบส่ง กฟผ.

respectively. The high-speed auxiliary relay shall be unlatched and reset, after the trouble is cleared, by operation of the annunciator reset push button. The annunciator and the shunt reactor auxiliary tripping and lockout relay circuits shall be electrically separated.

Each annunciator equipment shall include a reset push button and a lamp test push button mounted on the annunciator or immediately adjacent to the annunciator.

Annunciator panel, locate inside of the common control cabinet and shunt reactor control cabinet, to indicate all Individual trouble of the shunt reactor as listed in the “Common Control Cabinet Annunciator Trouble & Tripping Schedule (For Single phase Shunt Reactor)” and “Reactor Control Cabinet Annunciator Trouble & Tripping Schedule (For Single phase Shunt Reactor)” attached.

For Three Phase Shunt Reactor and Neutral Reactor;

When any trouble contact is closed, the corresponding auxiliary relay of at least two independent contacts, one for signal lamp on annunciator panel and the other for remote indication, shall be energized and selfheld which shall be reset, only if fault has already cleared, by the reset push button provided by the Contractor. Separated terminals shall be provided for each contact for remote indication.

Annunciator panel, locate inside of the control cabinet, to indicate all Individual trouble of the reactor as listed in the “Reactor Control Cabinet Annunciator Trouble & Tripping Schedule (For Three phase Shunt Reactor and Neutral Reactor)” attached shall be provided.

731-8.4 Winding Temperature Relay.

For Single Phase Shunt Reactor;

A total of three ambient temperature compensated winding temperature relays each with two sets of fully independent and adjustable switches with ungrounded contacts, factory adjusted to close at temperatures no higher than the following values.

- Contact set No.1- 110°C for alarm stage 1
- Contact set No.2-115°C for alarm stage 2

On decreasing temperature, contact sets No. 1 and No. 2 shall open at not more than 5°C below the closing temperature values. Similar contact sets of all relays shall be connected in parallel.

Sotakid Hmimom

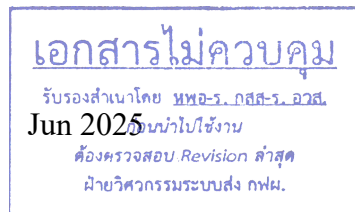

Each relay shall be responsive to the temperature of the hottest oil near the top of the shunt reactor plus winding rise above hot oil temperature. The winding hot spot rise response shall be provided by a heating coil connected to the secondary of a current transformer located to sense winding current. The bellows heater system, rather than the pocket system (heating coil in relay thermometer bulb well), of establishing winding temperature is preferred.

Leads and means for calibration of each relay shall be provided and terminated in a weatherproof housing located on the shunt reactor tank in a location convenient for inspection or testing.

All devices and accessories, including current transformers, required for operation of the relays shall be furnished.

The Contractor shall furnish all wiring and armoured cable or cable tray from the winding temperature relay equipment to the shunt reactor control cabinet.

For Three Phase Shunt Reactor and Neutral Reactor;

Any Reactor shall be provided with one set of winding temperature relay. Contacts for the two relays shall be connected in parallel.

Each set of winding temperature relay comprising of only one relay with ambient temperature compensation and two electrically separate sequence switches or at the Contractor's option, comprising of two relays with two or three switches each, may be furnished. The "make" and "break" temperatures of each switch shall be fully and independently adjusted. The first sequence switch will be used for alarm stage 1, and the second sequence switch will be used for alarm stage 2 and shall be suitable for operation on 125 Vdc. The heater of the winding temperature relay shall be connected to the secondary of a current transformer which has as its primary the lead to the reactor winding. The bellow heater system, rather than the pocket system (heating coil in relay thermometer bulb well), of establishing winding temperature shall be furnished. The temperature sensing device shall be located in the oil near the top of the reactor.

The relay or relays shall be designed to be responsive to the current in the windings and to top oil temperature and shall be calibrated to operate on the duration and magnitude of the temperatures of the reactor winding and oil. The relays shall be factory adjusted to close contacts at the temperature not more than the following values:

- Contact set No.1-110°C for alarm stage 1

-731.20-

Sotrajit Himmaman

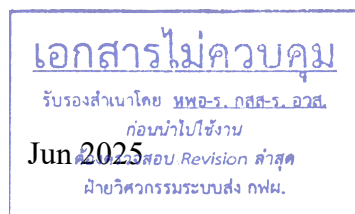

- Contact set No.2-115°C for alarm stage 2

With temperature decreasing the first and second sequence switches shall open contacts within 5°C below the closing values.

731-9 Accessories. Each shunt and neutral reactor shall be furnished complete with, but not limited to, the accessories listed below. All auxiliary relays and switches shall be for use in 125 Vdc control schemes. Electrically independent, dry contacts shall be provided with all devices for local annunciation, remote annunciation and sequence of events recording.

731-9.1 Oil Level Indicator. A dial type liquid level gauge with high and low-level alarm contact shall be furnished to monitor the reactor conservator oil level. The gauge shall be located for ease in reading from ground level. An output switch with output contacts shall be provided for annunciation. The relay shall include normally open contacts which shall be factory set to close when the oil level drops to an undesirable level. Dial range shall be matched with oil temp - oil level curve.

731-9.2 Oil Temperature Indicator. A dial type thermometer with the dial range of 0-150°C, display window shall be glass and alarm contact to close on high oil temperature shall be furnished to monitor the reactor oil temperature. The gauge shall be located for ease in reading from ground level at the reactor tank. Degree of Protection shall be IP65. 4-20 mA signal shall be provided.

731-9.3 Winding Temperature Relay. A winding hot-spot temperature detector of the Platinum resistance type 100 ohms (PT-100) at 0°C, shall be furnished together with necessary accessories, arranged for remote indication for use with a temperature recorder which will be provided and mounted on a switchboard by the others. The heater for the detector shall be connected to the secondary of a current transformer winding, and shall be located in the oil near the top of the reactor. A dial type meter with the range of 0-160°C shall be furnished for winding temperature indication at the reactor tank. The display window shall be glass. Two separately adjustable output switches shall be furnished, one for annunciation and the other for energizing a lockout relay. Degree of Protection shall be IP65. 4-20 mA signal shall be provided.

731-9.4 Buchholz Relay. A buchholz relay shall be furnished which will provide fault pressure and gas detecting features. The Buchholz relay shall be furnished with two contact outputs, one for alarm and the other for trip which shall be free from operation due to vibration. The relay shall be mounted in the connecting pipe between the main tank and the conservator and shall be complete with gas accumulation alarm feature. Valves with flange shall be provided for both sides of relay.

-731.21-

Sohaili Hanim

เอกสารไม่ควบคุม
 Jun 2025
 รับรองโดย มหอ-ร. กสส-ร. อดส.
 ก่อนนำไปใช้งาน
 ต้องตรวจสอบ Revision ล่าสุด
 ฝ่ายวิศวกรรมระบบส่ง กฟผ.

731-9.5 Drain and Filter Valves. In addition to the drain and filter valves required for the conservator and radiator, the main tank shall be furnished with drain and filter valves as listed below. The drain and filter valves shall be extended down and located for ease in operating from ground level.

- a. Two units for combination of drain valve and lower filter-press connection.
- b. Combination of upper filter valve, vacuum valve and upper oil filter-press connection.
- c. Isolating valve between the conservator and main tank.

731-9.6 Oil Sampling Device. The drain valve shall be equipped with a sample valve, not less than 6 mm, which must be installed on the outlet side of the drain valve. The drain valve shall be equipped with a plug.

731-9.7 Separate Stainless Steel Ground Terminal Connectors of clamp type located at reactor base provided for the followings:

- Surge arresters and discharge counter (if any)
- Neutral bushings
- Reactor tank
- Reactor control cabinet
- Common control cabinet (if any)
- Sound enclosure wall (if required)

The ground terminal connectors shall be suitable for No 4/0 AWG copper cable. All the ground leads shall be of No 4/0 AWG insulated ground wire fixed by porcelain insulators on the reactor tank. All ground leads shall be provided and connected from the above-mentioned equipment to ground terminal connectors.

731-9.8 Shunt Reactor External Neutral Connections. When a neutral reactor is not specified or applied, ground conductor connections shall be provided between the shunt reactor neutral bushings and from the neutral bushing to the grounding pad utilizing No.4/0 AWG insulated copper conductor completed with mounted porcelain insulators suitably supported on the tank. When a neutral reactor is utilized, Contractor shall provide conductor connections, including with 2 sets of 2 holes terminal pad (NEMA Standards CC1) for three-phase shunt reactor, from the shunt reactor neutral bushing to the neutral reactor and from the neutral reactor bushing to the surge arrester utilizing No.4/0 AWG insulated copper conductor.

731-9.9 Neutral Reactor External Neutral Connections. Ground conductor connections from the surge arrester, discharge counter and neutral bushing shall be installed. Ground

-731.22-

Sotrasidh Himmaman

เอกสารนี้ควบคุม
Jun 2025
นี้คือร่างสุดท้าย มหอ-ร. กสส-ร. อดส.
ก่อนนำไปใช้งาน
ต้องตรวจสอบ.Revision ล่าสุด
ฝ่ายวิศวกรรมระบบส่ง กฟผ.

conductor connections between the surge arrester and discharge counter and from discharge counter to the ground pad shall be made using No.4/0 AWG insulated copper conductor supported on the tank mounted porcelain insulators. Connections between the neutral bushing and the ground pad shall also be made using No.4/0 AWG insulated copper conductor completed with mounted porcelain insulators suitably supported on the tank.

731-9.10 Pressure Gauge for Transportation.

731-9.11 Three-dimensional shock recorder with time period recording chart of at least 3 months for transportation on the basis of returning back after the reactor arrive at the substation site. The permissible impact value of the reactor during transportation shall be designed not less than $\pm 3G$ in three dimensions (x, y, z axis).

731-9.12 Cover, Handholes and Manholes. A welded main cover, handholes and manholes for servicing shall be provided with following minimum dimension:

Handholes : 22.9 cm in diameter,
or 11.4 cm x 36.8 cm if rectangular

Manholes : 38.1 cm in diameter,
or 25.4 cm x 40.6 cm if rectangular

731-9.13 Core Ground. A single-core ground shall be provided and accessible from the tank exterior without removing oil to permit measurement of the core insulation. Cores shall be grounded at one point and two (2) bushings shall be provided for possible measuring the core insulation of 2.5 kV from top of the tank cover without lower the oil. One bushing for core and another bushing for core clamp.

731-9.14 Ladder. Ladder fixed on the reactor tank which is above ground level at 300 mm and extended to conservator for servicing the reactor. The caution plate to prevent an unauthorized person shall be provided.

731-9.15 Silica gel breather for main conservator.

731-9.16 Suitable jacking pads, pulling eyes and lifting lugs.

731-9.17 Lightning and outlet.

731-9.18 Gas sampling valve. A gas sampling valve shall be furnished and located such that gas sampling for the detection of gas formation can be obtained safely while the reactor is energized.

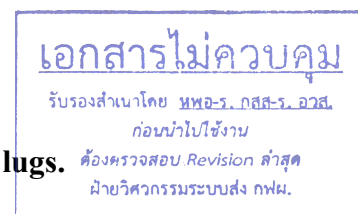

17 กุมภาพันธ์ 2569

Sotajid H...

731-10 Bushing Current Transformer. All bushing current transformers shall be in accordance with the latest IEC 61869-2 and shall have subtractive polarity. The bushing current transformers shall be in addition to those which may be required for operation of the temperature relays. The secondary leads from all bushing current transformers shall be brought to short-circuiting type terminal blocks located in the control cabinet. A separate 6 point terminal block shall be provided for each current transformer secondary winding. The terminal blocks shall be of short circuiting, molded type with insulating barriers, ring tongue crimp type terminals and marker strips, and shall be rated 600 V. Each terminal block shall be capable of accommodating two 6 mm² stranded conductors minimum for secondary current 5 A and two 4 mm² stranded conductors minimum for secondary current 1 A. Terminal blocks shall be arranged in a vertical row or rows. In case of slide-type terminal blocks are provided, fixed side shall be from secondary leads of bushing current transformers and slide side shall be for external connections to control room.

A minimum clear space of 125 mm shall be provided between terminal blocks and between terminal blocks and the cabinet sides for training connections to the terminal blocks. All terminal block connections shall be made using ring tongue, crimp type terminals. Each terminal block current transformer tap connection shall be marked to identify the associated tap. All current transformer secondary winding connections shall be 6 mm² minimum for secondary current 5 A and 4 mm² minimum for secondary current 1 A.

For Single Phase Shunt Reactor; All taps of each bushing current transformer shall be wired to the short-circuiting terminal block in the shunt reactor control cabinet and two wires from each CT short-circuiting terminal block to the common control cabinet. Current transformers in the same core location on each reactor shall be three phase grouped (A-B-C) top to bottom. The Contractor shall furnish all necessary wiring, cable tray and accessories for making the required current transformer to control cabinet and control cabinet to common control cabinet interconnections.

731-11 Surge Arrester. All surge arresters to be furnished shall meet all applicable requirements of the Specification of Metal Oxide Surge Arrester attached. When possible, the height of the arrester terminals shall match approximately the height of associated bushing terminals. Discharge counters with continuous AC leakage/internal current indicators shall be mounted approximately 1.5 m above ground level. Surge arrester to discharge counter to ground pad connections in accordance with the requirements stated herein shall be installed.

731-12 Device Contacts. All relay, gauge, thermometer and other device alarm and trip contacts shall be ungrounded, shall be positive, snap-action or mercury type and shall be rated at 125 Vdc. If necessary, interposing auxiliary relays may be furnished to satisfy these requirements.

Sotakid Hmimom

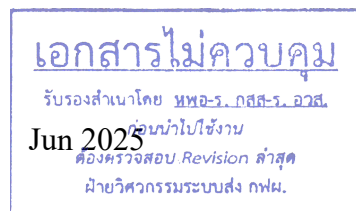

731-13 Gaskets. Gaskets shall be unaffected by hot insulating oil, retain their resiliency during the life of the associated equipment, and be unaffected by weather while maintaining oil and gas tightness. Nitrile gaskets shall be used except where the gaskets may be affected by heat, such as during welding. In such case, cork-neoprene or cork-Nitrile gaskets shall be provided. Gaskets of cork or neoprene only will not be allowed. Gasket flanges shall have grooves or stops to prevent gasket over compression.

731-14 Wind Load. Each completely assembled reactor shall be designed to withstand wind with a velocity up to 125 km/h without damage to or impairment of operation of the reactor or any part thereof.

731-15 Weight and Dimension Limitations. The Contractor shall furnish reactors that meet the EGAT shipping weight and dimension limitations described elsewhere. These shipping weight limitations reflect the maximum lifting weights that can be handled as well as the transportation weight limits to the installation site.

731-16 Use of Inert Gas or Dry Air for Transportation. Each core and coil unit shall be shipped in an atmosphere of inert gas or dry air to prevent moisture absorption. The core and coils shall be shipped as a unit in their tank. Transportation drawing including with detail of internal pressure of either tank or storage device shall be submitted for approval.

731-17 Cleaning & Painting. All interior and exterior surfaces of ferrous metalwork (including the sound enclosure, if required) shall be either galvanized in accordance with ASTM Designation A123 and A153 or painted. Surfaces to be painted shall be thoroughly cleaned to base metal by sand blasting or shot blasting and shall be thoroughly dry before application of any paint. After cleaning, the surfaces shall be given a priming or sealing coat of paint followed by two finishing coats. The paint used for the exterior finish coats shall have special heat, oil, and weather-resisting properties. The exterior surfaces of the reactor control cabinet and any other parts which expose to the outside looking (including the sound enclosure, if required) shall be painted in ANSI 70 light grey or MUNSELL NOTATION NO 7.5 BG 6/1.5. The total exterior paint thickness shall be a minimum of 105.

The Contractor shall furnish EGAT a quantity of factory supplied paint sufficient for one complete coat of the reactor.

731-18 Markings & Nameplates. Each reactor shall be provided with an attached identification nameplate or nameplates satisfying, but not limited to, the requirements of IEC 60076. The nameplate(s) shall include the EGAT contract number, item number and EGAT's serial number and be located to be readily legible from ground level. The nameplate and/or an adjacent nameplate shall include for each current transformer the accuracy class and primary and all secondary ampere ratings and identification of the terminal to which each applies, connection diagram of all windings, current transformer and associated devices shall be included in the

Sotrajit Hinman

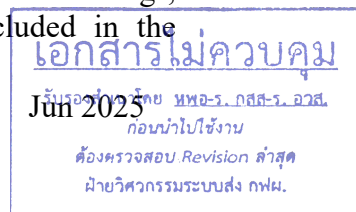

nameplate. The nameplates shall be black letters engraved on a background.

Individual nameplates shall also be furnished with each valve, oil sampling device, level device, temperature device, buchholz relay and all control cabinet devices which identify the device and pertinent characteristics.

Each reactor control, indicating and protective component, not otherwise clearly identified, shall be provided. All nameplate identification engraving shall be in English. Nameplate engraving shall be subject to EGAT approval.

All nameplates shall be anodized aluminum, stainless steel or other corrosion-resistant material and shall be attached with non-corroding screws.

731-19 Tests. Test for shunt reactor, neutral reactor, bushing, current transformers and accessories shall be tested in accordance with IEC 60076, IEC 60137 and IEC 61869. All power frequency testing shall be performed using a 50 Hz power supply. The Contractor shall be responsible for the costs of all testing.

731-19.1 Type Test. The reactors shall be subject to the actual type tests, unless otherwise specify in each test item.

731-19.2 Routine Test. Each equipment shall be completely assembled at the factory and subject to the tests specified in each equipment test item.

731-19.3 Test Report. The report of all tests, curves and standard application data shall be furnished to EGAT immediately after completion of the tests.

731-19.4 Test Procedure. The Contractor shall submit the test procedure of routine tests and actual type tests to EGAT for approval. The test procedure shall consist of procedures, applied voltage, current and criteria to justify the result of the tests.

731-19.5 Test Items for Type Test

- a. **Reactor.** One unit of reactor being supplied for each Ratings and Features shall be subject to the actual following test items, unless otherwise specify in each test item.

Shunt Reactor

1. Pressure and leakage test on reactor tank. The reactor tank shall be subject to an internal gas pressure of 1 kg/cm² for 30 minutes and under the pressure test the leakage shall be checked.

-731.26-

Sohalid Himmam

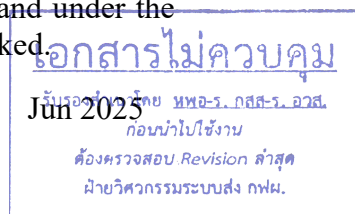

2. Vacuum test on reactor tank. The reactor tank shall be subject to a vacuum of less than 10 mmHg for 30 minutes, after the test, the deformation shall be checked.
3. Measurement of vibration for liquid-immersed reactors. The vibration shall be measured by transducers, optical detectors, or equivalent measuring device. Dynamic stresses shall be measured by means of strain gauges or it shall be calculated from vibration amplitudes and maximum dynamic stress shall not exceed 2,800 psi (20,000 kPa). The number of measurements shall be taken on all four sides and proposed to EGAT for approval.
4. Temperature rise test.
5. Measurement of loss close to reference temperature.
6. Measurement of acoustic sound level close to service temperature.
7. Jacking pad capability test. The test shall be performed on completed assembled reactor with oil for 30 min.

Neutral Reactor

1. Pressure and leakage test on reactor tank. The reactor tank shall be subject to an internal gas pressure of 1 kg/cm² for 30 minutes and under the pressure test the leakage shall be checked.
2. Vacuum test on reactor tank. The reactor tank shall be subject to a vacuum of less than 10 mmHg for 30 minutes, after the test, the deformation shall be checked.
3. Measurement of vibration at rated continuous current for liquid-immersed reactors. The vibration shall be measured by transducers, optical detectors, or equivalent measuring device. Dynamic stresses shall be measured by means of strain gauges or it shall be calculated from vibration amplitudes and maximum dynamic stress shall not exceed 2,800 psi (20,000 kPa). The number of measurements shall be taken on all four sides and proposed to EGAT for approval.

-731.27-

Sotajid Hirinam

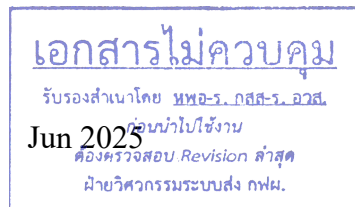

4. Temperature rise test at rated continuous current.
5. Measurement of acoustic sound level.
6. Jacking pad capability test. The test shall be performed on completed assembled reactor with oil for 30 min.

b. Bushing. The type tests are required in accordance with the latest IEC 60137. The tests shall be performed on one bushing of an identical unit. These tests may be omitted if a design test record of an identical unit can be submitted.

731-19.6 Test Items for Routine Test

a. Reactor. The Contractor shall perform the routine tests listed below on each shunt reactor and neutral reactor being supplied under this specification. The tests are defined and described in the referenced standards.

Shunt Reactor

1. Lightning impulse tests - consisting of reduced full-wave, chopped wave and full-wave tests on the complete reactor assembly including current transformers and bushings. Oscillograms of the tests shall be furnished to EGAT.
2. Switching impulse test
3. Measurement of winding resistance
4. Measurement of reactance (including measurement of zero-sequence reactance on three-phase reactors)
5. Measurement of loss
6. Dissolved gas analysis (DGA). DGA tests before and after the dielectric tests and before and after the temperature rise tests shall be performed. If the reactor is drained and refilled with oil during the performance of these tests, additional DGA tests shall be performed before draining and after refilling.
7. Separate source a.c. withstand voltage test
8. Induce a.c. withstand voltage test

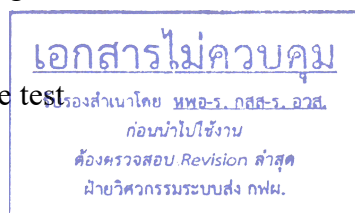

17 กุมภาพันธ์ 2569

9. Partial discharge measurement by using ERA-method
10. Measurement of insulation resistance
11. Measurement of capacitance and dissipation factor
12. Determination of linearity of reactance. Linearity tests shall be provided on the shunt reactors up to 1.50 x rated voltage. The test voltage shall be raised up 10% for each step and measured at rated voltage, maximum operating voltage, 120%, 125%, 130%, 140% and 150% x rated voltage.
13. Leak tests. Leak tests shall be provided showing positive tank sealing up to rated tank pressures.
14. Measurement of acoustic sound level.
15. Frequency response measurement. The measuring frequency range shall be from 10 Hz to 1 MHz. The result shall be plotted by "impedance VS frequency" and "phase angle VS frequency".

Neutral Reactor

1. Measurement of winding resistance
2. Measurement of impedance at rated continuous current
3. Measurement of impedance at rated short-time current
4. Measurement of loss at ambient temperature
5. Dissolved gas analysis (DGA). DGA tests before and after the dielectric tests and before and after the temperature rise tests shall be performed. If the reactor is drained and refilled with oil during the performance of these tests, additional DGA tests shall be performed before draining and after refilling.
6. Separate source a.c. withstand voltage test for liquid-immersed reactors
7. Winding overvoltage test
8. Partial discharge measurement by using ERA-method

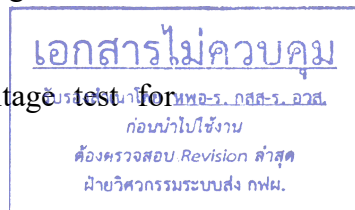

17 กุมภาพันธ์ 2569

9. Measurement of insulation resistance
 10. Measurement of capacitance and dissipation factor
 11. Determination of linearity of impedance. Linearity tests shall be provided on the neutral reactors up to the 10 s short time overvoltage rating of 1.4 x rated voltage. The test voltage shall be raised up 10% for each step and measured at rated voltage, maximum operating voltage, 120%, 125%, 130% and 140% x rated voltage.
 12. Leak tests. Leak tests shall be provided showing positive tank sealing up to rated tank pressures.
 13. Frequency response measurement. The measuring frequency range shall be from 10 Hz to 1 MHz. The result shall be plotted by "impedance VS frequency" and "phase angle VS frequency".
- b. Bushing.** The Contractor shall perform the routine tests on all bushings according to IEC 60137.
- c. Current Transformer.** The Contractor shall perform the routine tests on all current transformers. The tests shall be performed in accordance with the latest IEC 61869-2.
- d. Material and Accessory Tests Report.** Test report of the following material and accessories used in each supply shall be submitted.
1. Insulating oil
 2. Core steel
 3. Winding conductor
 4. Insulation paper and pressboard
 5. Radiator
 6. Reactor supervisory equipment
 - (a) Oil level indicator
 - (b) Oil temperature indicator
 - (c) Winding temperature relay / Winding hot spot detector
 - (d) Buchholz relay
 - (e) Pressure relief device
 - (f) Rubber bag rupture detector
- e. Information for Reference.** The following information for each reactor shall be submitted and attached in routine test report for maintenance purpose.

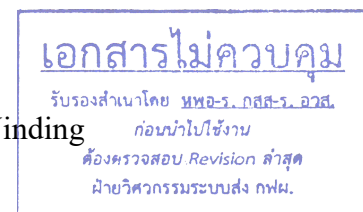

17 กุมภาพันธ์ 2569

Sotajid Hirinam

- Torque value on clamping bolts or pressure for the winding before assembly and after complete assembly.
- Photograph of coil for each phase and photograph of core and coils assembly. The photograph of coil shall be taken from the final production process before placing to the core (if any), top view and front view shall be provided. The photograph of core and coil assembly shall be taken just prior to place the completed core and coil assembly into the tank, top view, front view, right view, left view and rear view shall be provided for complete set of photographs.

731-20 Spare Parts. Spare parts as specified in Price Schedule and one complete set of spare gaskets for each reactor to be used during erection at site shall be supplied. All spare parts including spare gasket subject to damage or deterioration by moisture shall be packed in moisture-proof material. All spare parts shall be of the same material and workmanship as the corresponding original parts and shall be interchangeable there with.

731-21 Appliances and Tools. The Contractor shall furnish all special appliances and tools that the equipment manufacturer deems necessary for satisfactory installation, operation, testing and maintenance of the equipment, including assembly and disassembly. Special tools and appliances shall be constructed as those that are not readily available from appliance and tool suppliers in Thailand and those that the equipment manufacturer has procured or fabricated for use with the equipment or similar equipment. The Contractor shall submit to EGAT for approval a list of all appliances and tools required for above stated purposes and shall indicate thereon all furnished appliances and tools.

731-22 Final Design Data. The Contractor shall furnish the following final design data for each reactor based on final design calculation:

- Losses in kilowatts at rated voltage and rated frequency at 80 °C. The equation of the losses in magnetic shunt or core at the voltage corresponding to rated current (P_f) shall be submitted.
- Over excitation
 - Capability duration time at 105/125/140% rated voltage (50 Hz)
 - Capability duration time at 100% rated voltage (48 Hz)
 - Overvoltage for 10 s (50 Hz)
- Continuous current for 10 min of neutral reactor without mechanical failure.
- Temperature rise of top oil and winding including hot spot factor. The detail of hot spot factor, formula with all parameters or simulation graph, shall be submitted.
- Linearity Curve

-731.31-

Sotakajit Himmirong

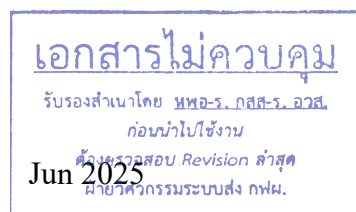

- For shunt reactor: The range of graph shall cover 1.5 times of rating.
 - For neutral reactor: The range of graph shall cover 1.4 times of rating.
- f) Overall dimensions and weight of all principal parts.
 - g) Identification by name and total weight and dimensions of heaviest part that must be lifted by the crane during assembly and disassembly.
 - h) Impedance in ohms at rated voltage and rated frequency
 - Resistance
 - Reactance
 - Total impedance
 - Zero sequence reactance
 - i) Detailed calculation showing all parameters of mechanical stress and force result of neutral reactor shall be submitted to demonstrate that the neutral reactor as designed can withstand the effects of through faults. The data of proof stress of winding shall be submitted.
 - j) Detailed calculation of designed vibration limit including formula and values of young modulus or other factors. Designed resonance frequency shall be provided with its designed criteria.
 - k) Designed audible noise level.
 - l) Internal construction of core and winding. The construction shall be showing arrangement of each phase and the shielding between phases (if any). Technical documents of any disks to make the gap of main limb of shunt reactor shall be provided.

In case of the sound enclosure is required, all of final design data shall be calculated and considered the reactor completed with the sound enclosure.

Increase in values of items (f) and (g) over those given in the Proposal Data shall be limited to 10% but not more than EGAT's specified values elsewhere.

EGAT reserves the right to review the detailed design of reactor without changing the guaranteed losses values.

731-23 Drawings and Documents for Shunt and Neutral Reactor. Drawings and documents for approval shall at least comprise of the following;

Final Design Data is the first document required to submit for approval after confirmation of letter of award of Contract.

A. Drawings for Approval

Sotajid Hirinam

-731.32-

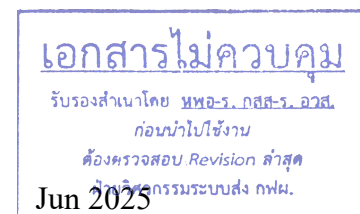

Item	Drawings Title	Approval and Final Dwgs	AutoCAD files	CD-ROM or USB flash drive
1	Drawing list of all drawings submitted for approval	x	-	x
2	Shunt and neutral reactor outline including legend of all accessories	x	x	x
3	Shunt and neutral reactor bottom view showing the skidding base	x	x	x
4	Shunt and neutral reactor foundation including location of control cabinet and grounding terminals	x	x	x
5	Shipping and transportation sketch. (Main tank, etc.) including the value of pressure, moisture content and allowable impact figures	x	x	x
6	Shunt and neutral reactor nameplate including Shunt and neutral reactor top and front view with dimension	x	-	x
7	CT connecting plate complete with current ratio	x	-	x
8	Oil temp – oil level curve plate	x	-	x
9	Control schematic diagram with terminals indication of each relay, contact, switch, etc. - AC & DC control - Annunciator, alarm & trip circuits with indication of the setting value of all protective devices	x	x	x
10	Shunt and neutral reactor control cabinet and common control cabinet (if any) outline (including indication of accessories location, nameplate of each accessory and annunciator windows with abbreviation of faults)	x	x	x
11	Bushing outline	x	-	x
12	Terminal pad of Bushing and Surge Arrester	x	-	x
13	Grounding terminal connector	x	-	x
14	Terminal blocks layout of real physical arrangement including terminals indication and indication for external connection in shunt and neutral reactor control cabinet and common control cabinet (if any)	x	-	x

Sotakid Hmimom

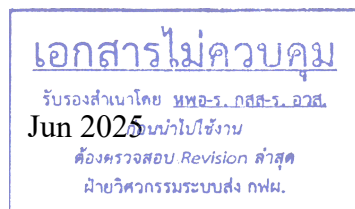

Item	Drawings Title	Approval and Final Dwgs	AutoCAD files	CD-ROM or USB flash drive
15	Wiring diagram (including internal wiring diagram) in the shunt and neutral reactor control cabinet and common control cabinet (if any)	x	-	x
16	Wiring connection of supervisory equipment including indication or wire sizes	x	-	x
17	Oil piping and valve connection diagram	x	-	x
18	Grounding connection arrangement with ground wire size indication	x	-	x
19	List of gasket and position with dimension			
20	List of spare parts and spare gaskets with shape, quantity and dimension (for each spare part)	x	-	x
21	Secondary terminal arrangement of BCT	x	-	x
22	Test tap outline for all bushings	x	-	x
23	Conservator and rubber bag with sizing calculation	x	-	x
24	Detailed connection of surge arrester, discharge counter and ground terminal connector	x	-	x
25	Connection layout for shunt reactor and neutral reactor (if any)	x	-	x
26	Bushing turret with its dimension and details of BCT	x	-	x
27	Un-tanking sketch (detail for lifting core and coil for maintenance purpose)	x	-	x
28	Sound enclosure (if required)	x	x	x

B. Document for Approval

- Description of contact capacity of all relays
- List of tools and appliances
- Load list of shunt and neutral reactor control cabinet
- Container list
- Magnetic field plot of shunt and neutral reactor
- Package for long term storage of bushing

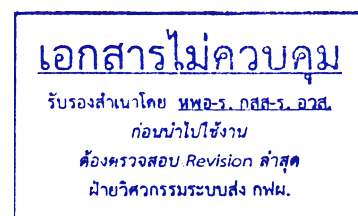

17 กุมภาพันธ์ 2569

C. Data and Description Material

- Bushing current transformer secondary excitation and ratio correction factor curves for each ratio.

Sotajid Hmimom

- b) Operating description for
- Cooling control
 - Annunciating and tripping circuit
- c) Description or catalog data and drawings for
- Conservator of reactor tank
 - Pressure gauge for transportation of reactor tank
 - Pressure relief device
 - Buchholz relay
 - Air detector relay for conservator
 - Winding temperature relay
 - Winding hot spot temperature detector
 - Dial type oil level gauge
 - Dial type oil temperature indicator
 - Auxiliary tripping and lockout relay
 - All kinds of auxiliary relay
 - AC & DC undervoltage relay
 - All kinds of selector switch, control switch and push button
 - Silica gel breather
 - All kind of valves
 - Oil sampling device
 - Radiator
 - Reactor gaskets characteristic
 - Insulating oil characteristics
 - Reactor insulation material and pressboard
 - Outlet of 20 A, 250 Vac
- d) Component Part Data - One drawing shall be furnished showing the following information, as applicable, for each component part (contractors, relays, auxiliary relays, control devices, switches, etc.)
- Manufacturer
 - Manufacturer's type and/or catalog number
 - Rating
 - Type and number of contacts
 - Contact AC and DC continuous, make and resistive and inductive interrupting ratings
 - Coil impedance and power factor

เอกสารไม่ควบคุม

รับรองสำเนาโดย ทพอ.ร.กสส.ร.อวส.

ก่อนนำไปใช้งาน

ต้องตรวจสอบ.Revision สำสุด

ฝ่ายวิศวกรรมระบบส่ง กฟผ.

17 กุมภาพันธ์ 2569

Sotajid Hmangm

731-24 Instruction Manual for Shunt and Neutral Reactor. Instruction manual shall consist of all necessary information and shall comprise of at least the following parts.

Part A Reactor instruction including installation, operation and maintenance manuals.

a. Reactor general technical information

b. Installation instruction including but not limited to

- Moving method for the reactor tank by skidding on the rollers
- Moving method for complete assembly reactor by skidding on the rollers
- Inspection including interpretation of shock recorder level
- Flow chart of installation
- Installation instruction
- Vacuum oil filling
- Method of drying out at site
- Characteristic of insulating oil
- Tank assembly
- External assembly for complete reactor
- Detailed assembly of the sound enclosure at site (if any)

c. Maintenance and Operation instruction

- Routine inspection
- Maintenance
- Operation guide
- Guide for maintenance of long storage reactor
- Interpretation of gas analysis for reactor in service
- Internal assembly of reactor
- Guide for maintenance and inspection of the sound enclosure (if any)

Part B Instruction and manual catalogs including installation and maintenance manual of all accessories.

Part C Complete set of all final drawings.

Part D Final design data.

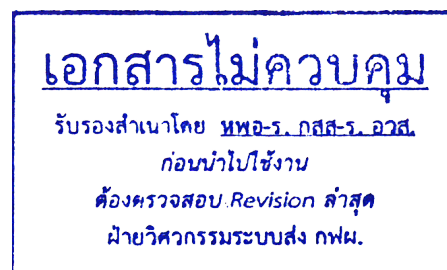

17 กุมภาพันธ์ 2569

Sotavajit Himmam

Layout for installation of Single Phase Shunt Reactor

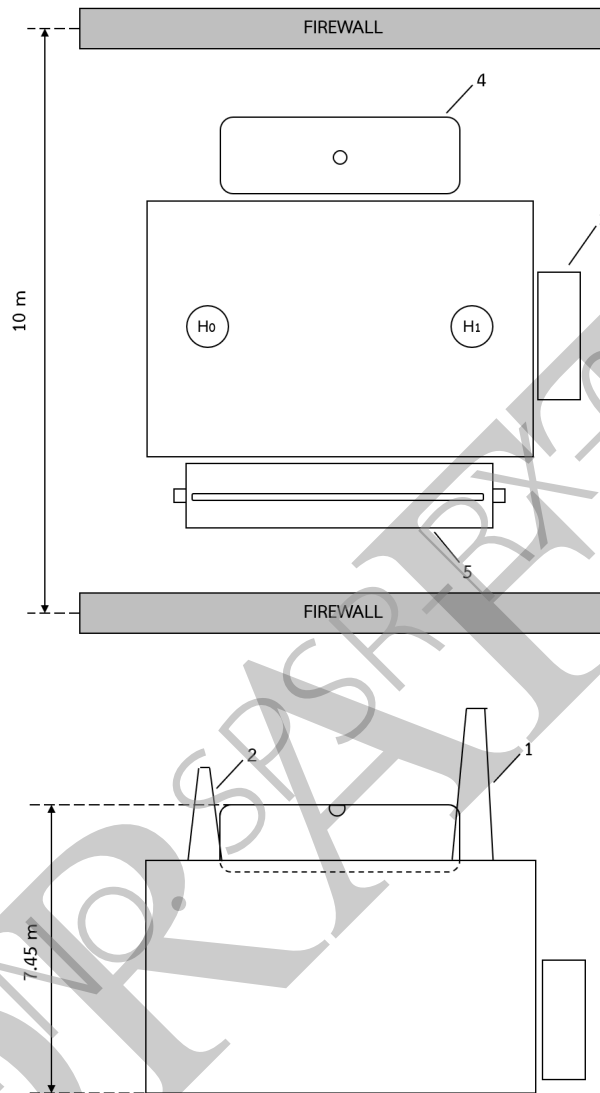

No.	Description
1.	HV Bushing
2.	Neutral Bushing
3.	Reactor Control Cabinet
4.	Conservator
5.	Radiator

เอกสารไม่ควบคุม

รับรองสำเนาโดย นพอ.ร.กสส-ร.อวส.
ก่อนนำไปใช้งาน

ต้องตรวจสอบ Revision ล่าสุด
ฝ่ายวิศวกรรมระบบส่ง กฟผ.

17 กุมภาพันธ์ 2569

* Location of Radiators and Conservator are depended on manufacturer's design

Sotajida Himmam

Bushing Location for Three Phase Shunt Reactor

Neutral Side

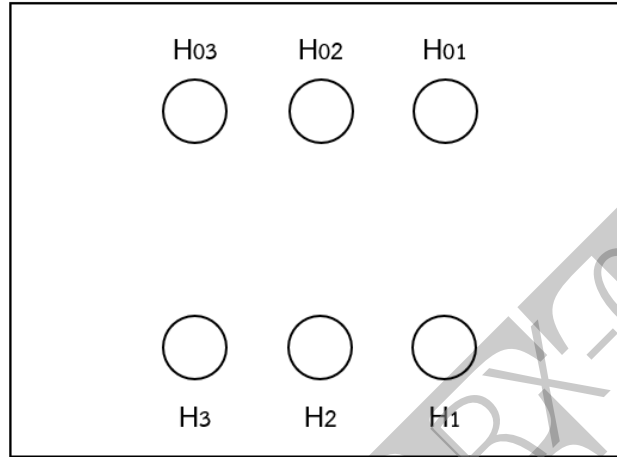

High Voltage Side

LEFT HAND

RIGHT HAND

เอกสารไม่ควบคุม

รับรองสำเนาโดย **พ.อ.ร. กสส.ร. อวส.**

ก่อนนำไปใช้งาน

ต้องตรวจสอบ *Revision* สำสุด

ฝ่ายวิศวกรรมระบบส่ง กฟผ.

17 กุมภาพันธ์ 2569

Sotavade Himmam

Shunt Reactor Control Cabinet					
Power Consumption (AC)					
Equipment	Manufacturer	Power Consumption (W)	Qty	Total Power Consumption (W)	Continuous Load (Operate over 3 hrs. continuously) Yes/No
1.					
2.					
3.					
4.					
Total					

Shunt Reactor Control Cabinet					
Power Consumption (DC)					
Equipment	Manufacturer	Power Consumption (W)	Qty	Total Power Consumption (W)	Continuous Load (Operate over 3 hrs. continuously) Yes/No
1.					
2.					
3.					
4.					
Total					

Neutral Reactor Control Cabinet					
Power Consumption (AC)					
Equipment	Manufacturer	Power Consumption (W)	Qty	Total Power Consumption (W)	Continuous Load (Operate over 3 hrs. continuously) Yes/No
1.					
2.					
3.					
4.					
Total					

Neutral Reactor Control Cabinet					
Power Consumption (DC)					
Equipment	Manufacturer	Power Consumption (W)	Qty	Total Power Consumption (W)	Continuous Load (Operate over 3 hrs. continuously) Yes/No
1.					
2.					
3.					
4.					
Total					

เอกสารไม่ควบคุม
 รับรองสำเนาโดย นพอ.ร. กสส.ร. อวส.
 ก่อนนำไปใช้งาน
 ต้องตรวจสอบ .Revision สำสุด
 ฝ่ายวิศวกรรมระบบส่ง กฟผ.

17 กุมภาพันธ์ 2569

Sotavijit Himmam

REACTOR CONTROL CABINET ANNUNCIATOR

TROUBLE & TRIPPING SCHEDULE

(For Single phase Shunt Reactor)

Item	Trouble	Annunciator Window Legend	Tripping
1	Oil temperature high	OIL TEMP HI	
2	Oil level low	OIL LEVEL LO	
3	Oil level high	OIL LEVEL HI	
4	Pressure relief device operation	PRESS RELIEF ALARM	
5	Winding temperature alarm stage 1	WDG TEMP ALARM STG 1	
6	Winding temperature alarm stage 2	WDG TEMP ALARM STG 2	
7	Buchholz relay operation (alarm)	BUCHHOLZ RLY ALARM	
8	Buchholz relay operation (trip)	BUCHHOLZ RLY TRIP	yes
9	Conservator rubber bag rupture detector relay operation	RUBBER BAG RUPTURE	
10	Loss of three phase AC control power (three phase undervoltage relay)	LOSS OF AC SUPPLY	
11	Loss of DC control power (undervoltage relay)	LOSS OF DC SUPPLY	
12	Branch AC control power ACB trip (ACB alarm contacts)	LOSS OF AC CONTROL PWR	
13	Branch DC control power ACB trip (ACB alarm contacts)	LOSS OF DC CONTROL PWR	

เอกสารไม่ควบคุม

รับรองสำเนาโดย มหอร. กสส-ร. อวส.

ก่อนนำไปใช้งาน

ต้องตรวจสอบ.Revision ล่าสุด

ฝ่ายวิศวกรรมระบบส่ง กฟผ.

17 กุมภาพันธ์ 2569

Sotavajda H...

COMMON CONTROL CABINET ANNUNCIATOR

TROUBLE & TRIPPING SCHEDULE

(For Single phase Shunt Reactor)

Item	Trouble	Annunciator Window Legend
1	Low of three phase AC control power (three phase undervoltage relay)	LOSS OF AC SUPPLY
2	Loss of DC control power (undervoltage relay)	LOSS OF DC SUPPLY
3	Branch AC control power ACB trip (ACB alarm contacts parallel)	LOSS OF AC CONTROL PWR
4	Branch DC control power ACB trip (ACB alarm contacts parallel)	LOSS OF DC CONTROL PWR
5	Phase A annunciator operated (annunciator common alarm contact)	PHASE A TROUBLE
6	Phase B annunciator operated (annunciator common alarm contact)	PHASE B TROUBLE
7	Phase C annunciator operated (annunciator common alarm contact)	PHASE C TROUBLE
8	Lockout Operate	LOCKOUT OPERATE
9	Cut off selector switch operate	CUT OFF SW. OPERATE

เอกสารไม่ควบคุม

รับรองสำเนาโดย **หพอ.ร.กสส.ร.อวส.**

ก่อนนำไปใช้งาน

ต้องตรวจสอบ **Revision** สำสุด

ฝ่ายวิศวกรรมระบบส่ง กฟผ.

17 กุมภาพันธ์ 2569

Sotajide Hmimom

REACTOR CONTROL CABINET ANNUNCIATOR

TROUBLE & TRIPPING SCHEDULE

(For Three phase Shunt Reactor and Neutral Reactor)

Item	Trouble	Annunciator Window Legend	Tripping
1	Oil temperature high	OIL TEMP HI	
2	Oil level low	OIL LEVEL LO	
3	Oil level high	OIL LEVEL HI	
4	Pressure relief device operation	PRESS RELIEF ALARM	
5	Winding temperature alarm stage 1	WDG TEMP ALARM STG 1	
6	Winding temperature alarm stage 2	WDG TEMP ALARM STG 2	
7	Buchholz relay operation (alarm)	BUCHHOLZ RLY ALARM	
8	Buchholz relay operation (trip)	BUCHHOLZ RLY TRIP	yes
9	Conservator rubber bag rupture detector relay operation	RUBBER BAG RUPTURE	
10	Loss of three phase AC control power (three phase undervoltage relay)	LOSS OF AC SUPPLY	
11	Loss of DC control power (undervoltage relay)	LOSS OF DC SUPPLY	
12	Branch AC control power ACB trip (ACB alarm contacts)	LOSS OF AC CONTROL PWR	
13	Branch DC control power ACB trip (ACB alarm contacts)	LOSS OF DC CONTROL PWR	
14	Lockout Operate	LOCKOUT OPERATE	
15	Cut off selector switch operate	CUT OFF SW. OPERATE	

-731.42-

Sotraside Himmam

เอกสารไม่ควบคุม
Jun 2025 มหอ-ร. กสส-ร. อวส.
 ก่อนนำไปใช้งาน
 ต้องตรวจสอบ Revision ล่าสุด
 ฝ่ายวิศวกรรมระบบส่ง กฟผ.

TYPICAL SCHEMATIC DIAGRAM NO.1

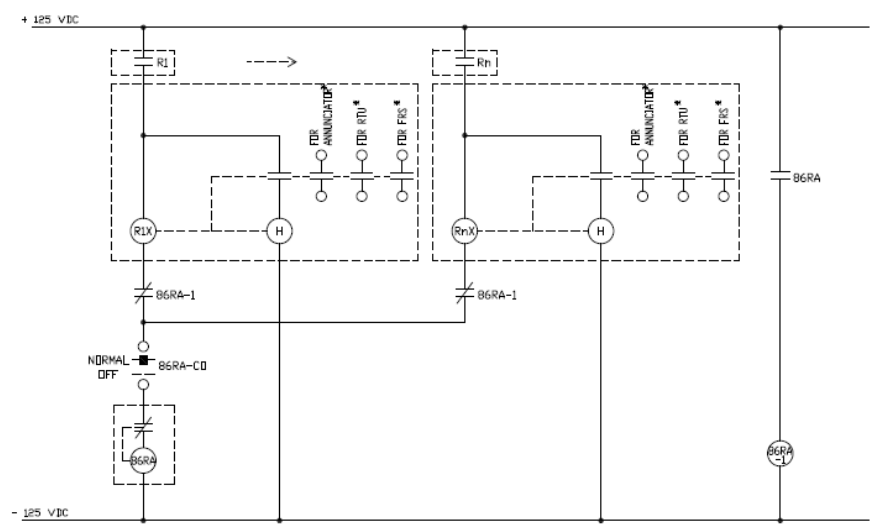

TYPICAL SCHEMATIC DIAGRAM NO.2

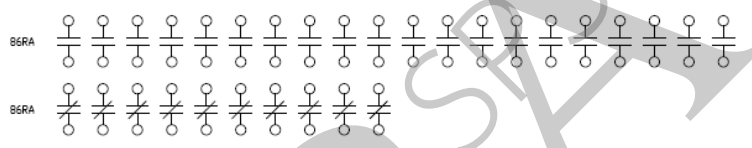
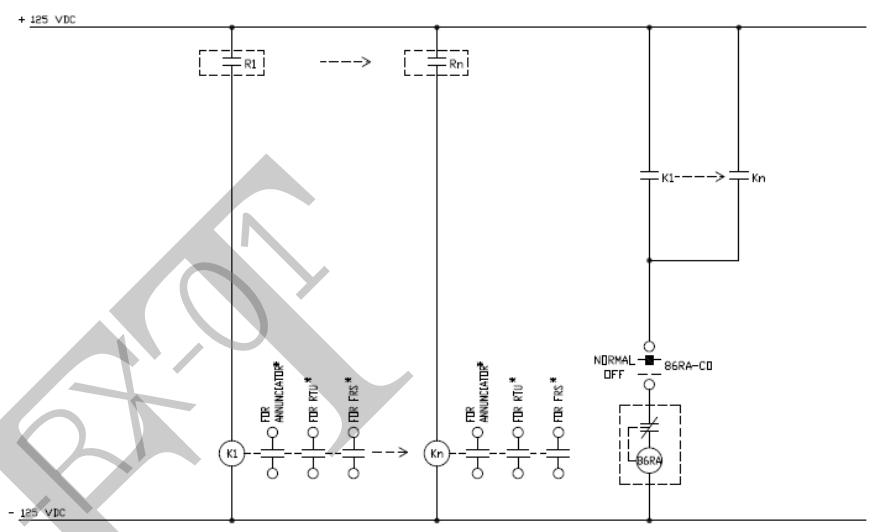

LEGEND

LEGEND	DESCRIPTION
R1...Rn	TROUBLE CONTACTS FROM SHUNT REACTOR
R1X...RnX	CURRENT RELAY WITH HOLDING COIL
K1...Kn	HIGH SPEED RELAY
B6RA	HIGH SPEED TRIPPING AND LOCKOUT RELAY
B6RA-1	AUXILIARY RELAY
B6RA-CD	CUT-OFF SWITCH

NOTE
 * FOR SINGLE PHASE SHUNT REACTOR, THE CONTACTS FOR FRS AND RTU ARE SEPARATELY REQUIRED IN EACH PHASE.

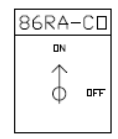

B6RA-CD CUT-OFF SWITCH POSITION

CONTACT	POSITION	
	ON	OFF
1 - 2	X	
3 - 4	X	
5 - 6	X	
7 - 8	X	
9 - 10	X	
11 - 12	X	
13 - 14	X	
15 - 16		X
17 - 18		X
19 - 20		X

ELECTRICITY GENERATING AUTHORITY OF THAILAND

DRAWN	RECOMMENDED AND VALIDATED	DRAWING NAME
DESIGNED	CONCLUDED	TYPICAL DRAWING
VERIFIED	APPROVED	SHUNT REACTOR TRIPPING TYPICAL SCHEMATIC DIAGRAM
DATE	DATE	JOB NO. REFERENCE SYMBOLS
		XXXX-XX.X

REVISED	JOB NO.	JOB DESCRIPTION	DRAWN	DESIGNED	VERIFIED	VALIDATED	RECOMMENDED	CONCLUDED	APPROVED	DATE

-731.43-

Jun 2025

เอกสารไม่ควบคุม
 รับรองสำเนาโดย พทอ.ร. กตส.ร. อ.พ.
 ก่อนนำไปใช้งาน
 ต้องตรวจสอบ Revision คำสั่ง
 ฝ่ายวิศวกรรมระบบส่ง กฟผ.

SPECIFICATION OF MINERAL INSULATING OIL

REVISION 7.3.1

1. General

The new mineral insulating oil obtained by refining, modifying and/or blending of original petroleum products is used as an insulating and cooling medium in new and existing power as well as distribution electrical apparatus, such as transformers, regulators, reactors, circuit breakers, switchgears, and attendant equipment where greater oxidation resistance is required. The mineral insulating oil shall be functionally interchangeable, miscible with existing oil, compatible with existing apparatus and with appropriate field maintenance. It shall satisfactorily maintain its functional characteristics in its application in electrical equipment. This specification applies only to new insulating oil which is received before any processing.

2. Property Requirements

The property requirements of mineral insulating oil shall conform to ASTM D 3487-2016e1 Type II Mineral oil (see Clause 3.1.2 for definitions of ASTM or IEC 60296-2020 Edition 5.0 Type A Mineral oil (see Clause 5.1 for definitions of IEC) and EGAT experiences. Inhibited oil is insulating oil which has been supplemented with 2,6-ditertiary-butyl phenol or 2,6-ditertiary-butyl para-cresol or any other specified and acceptable oxidation inhibitor. If other additives are used, they must be identified. Generally, the additive is a suitable chemical substance which is deliberately added into the mineral insulating oil to improve certain characteristics. So, the use of all additives, such as pour point depressants, gassing tendency improvers, additives for static electrification, antifoaming agents and other additives, should be specifically identified by class of compounds if the specific information is proprietary, except the additive for this specification must be free from additive for corrosive sulfur.

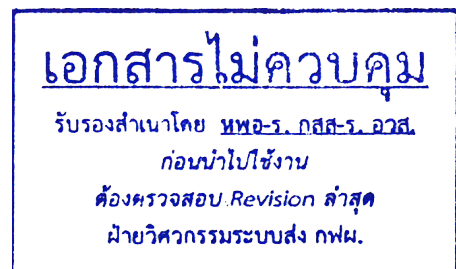

17 กุมภาพันธ์ 2569

Property		ASTM D 3487 Requirements	IEC 60296 Requirements	*EGAT Requirements
2.1	Color	0.5, max	L0.5 (less than 0.5)	-
2.2	Flash point, °C	145, min	135, min	-
2.3	Interfacial Tension at 25 °C dynes/cm (mN/m)	40, min	43, min	-
2.4	Pour point, °C	-40, max ^(B)	-40, max	-
2.5	Relative density (Specific gravity) 15°C/15°C, g/ml	0.91, max	-	-
2.6	Density at 20°C, g/ml	-	0.895, max	-
2.7	Viscosity, Kinematics cSt (SUS) at 100°C at 40°C at 0°C at -30°C	3.0 (36), max 12.0 (66), max 76.0 (350), max -	- 12.0, max - 1,800, max	- - - -
2.8	Visual examination	clear and bright	-	-
2.9	Appearance	-	clear, free from sediment and suspended matter	-
2.10	Dielectric breakdown voltage VDE electrodes, kV 0.040 in (1.02 mm.) gap 0.080 in (2.03 mm.) gap	20, min ^(D) 35, min ^(D)	- -	20, min ^(A) 35, min ^(A)
2.11	Dielectric breakdown voltage, kV	-	30, min	See note EGAT Requirements ^(A)
2.12	Dielectric breakdown voltage, Impulse conditions Negative polarity point, kV	145, min	-	145, min See note EGAT Requirements ^(B)

เอกสารไม่ควบคุม

รับรองสำเนาโดย ทพอ.ร. กสส.ร. อวส.
ก่อนนำไปใช้งาน
ต้องตรวจสอบ Revision ล่าสุด
ฝ่ายวิศวกรรมระบบส่ง กฟผ.

17 กุมภาพันธ์ 2569

-731.45- *Sotavijda Himmam*

Jun 2025

	Property	ASTM D 3487 Requirements	IEC 60296 Requirements	*EGAT Requirements
2.13	Gassing Tendency, $\mu\text{L}/\text{min}$	+30, max	-	See note EGAT Requirements ^(C)
2.14	Power factor (Dissipation factor) at 60 Hz, % at 25 °C at 90 °C at 100 °C	0.05, max - 0.30, max	- 0.005, max -	- - -
2.15	Neutralization number, Total acid number, Acidity mg KOH/g	0.03, max	0.01, max	-
2.16	Oxidation stability (acid-sludge test) 72 hrs: % sludge, by mass Total acid number, mg KOH/g 164 hrs: % sludge, by mass Total acid number, mg KOH/g	0.1, max 0.3, max 0.2, max 0.4, max	- - - -	- - - -
2.17	Oxidation stability IEC 61125: Test duration (I) Inhibited oil: 500 h Total acidity, mg KOH/g Sludge, % DDF at 90° C	- - -	0.3, max ^(h) 0.05, max ^(h) 0.050, max ^(h)	- - -
2.18	Oxidation stability (pressure vessel test), (Rotating Bomb), minutes	195, min	-	220, min ^(D)
2.19	Oxidation inhibitor content % by mass	0.30, max ^(G)	0.08-0.40	-

เอกสารไม่ควบคุม

รับรองสำเนาโดย นพอ.ร. กสส.ร. อวส.
ก่อนนำไปใช้งาน
ต้องตรวจสอบ Revision ล่าสุด
ฝ่ายวิศวกรรมระบบส่ง กฟผ.

17 กุมภาพันธ์ 2569

-731.46- *Sotajid Himmam*

Jun 2025

Property		ASTM D 3487 Requirements	IEC 60296 Requirements	*EGAT Requirements
2.20	2-Furfural and related compounds content, µg/l	25, max per compound	Not detectable (< 0.05 mg/kg) for each individual compound	25, max ^(E) (for each individual compound)
2.21	Corrosive sulfur copper strip, 150 °C 48 hrs Potentially corrosive copper conductor wrapped with paper, 150 °C±2°C 72 hrs, evaluation of -copper -paper	Non-Corrosive - -	- Non-Corrosive No deposits	Non-Corrosive ^(F) Non-Corrosive ^(F) No deposits
2.22	Dibenzyl disulfide (DBDS), mg/kg	-	Not detectable (<5 mg/kg)	Not detectable (<5 mg/kg)
2.23	Water content, ppm	35, max	30, max	-
2.24	% PCA content (Polycyclic aromatics)	-	3, max	-
2.25	PCB content	Not detectable	Not detectable (<2 mg/kg)	-
2.26	% Total Sulphur content	-	0.05, max	-
2.27	Stray gassing under thermo-oxidative stress	-	Non stray gassing	-

*in case of any test item meets EGAT Requirements, that limit becomes accepted.

เอกสารไม่ควบคุม
รับรองสำเนาโดย **หพอ-ร.กสส-ร.อวส.**
ก่อนนำไปใช้งาน
ต้องตรวจสอบ **Revision** สำสุด
ฝ่ายวิศวกรรมระบบส่ง กฟผ.

17 กุมภาพันธ์ 2569

-731.47- *Sotajid Hmimom*

Jun 2025

Note :

ASTM D 3487 Requirements

- ^(B) It is common practice to specify a lower or higher pour point, depending upon climatic conditions.
- ^(D) These limits by Test Method D 1816 are applicable only to as received new oil.
- ^(G) Both 2,6-ditertiary-butyl para-cresol and 2,6-ditertiary-butyl phenol have been found to be suitable oxidation inhibitors for use in oils meeting this specification.

IEC 60296 Requirements

- ^(h) At the end of oxidation stability tests.

EGAT Requirements

- ^(A) These limits by Test Method ASTM D1816 are applicable only to as received new oil.
- ^(B) EGAT prefers oil of a 145 kV minimum for certain applications.
- ^(C) The characteristic should be negative. If the characteristic is positive, the value should be near test report from supplier ($\pm 10\%$). In case the characteristic is positive, this oil cannot be used in Instrument transformer and bushing.
- ^(D) Good oxidation stability is a principal requirement for long service life of transformer oils.
- ^(E) The test is for five furanic compounds, 5-hydroxymethyl-2-furfural, furfuryl alcohol, 2-furfural, acetyl furan and 5-methyl-2-furfural. The limit of 25 μ g/L maximum applies to each compound.
- ^(F) Classification of corrosive or non-corrosive shall be made using ASTM copper strip corrosion standards as referred to test method ASTM D130.

เอกสารไม่ควบคุม

รับรองสำเนาโดย **พ.อ.ร. กสส.ร. อวส.**

ก่อนนำไปใช้งาน

ต้องตรวจสอบ **Revision** สำสุด

ฝ่ายวิศวกรรมระบบส่ง กฟผ.

17 กุมภาพันธ์ 2569

Sotavijda Hmimom

3. Container

The mineral insulating oil shall be filled in non-returnable, 200 liters steel drums which shall become the property of EGAT. The filling date of insulating oil shall be declared on each drum.

Steel Drums 200 Liters (Tight Head)

For the packing of	Transformer oil
Nominal Capacity (Litres)	200
Nominal Capacity (Gallon)	55
Max Capacity (Litres)	217
Raw Material	Cold Rolled Steel Spec: JIS.G. 3141 SPCC-SD (Prime A.)
Thickness Body (mm)	0.9 ± 0.06
Thickness Top/Bottom (mm)	1.2 ± 0.08
Overall Height (mm)	887
Closure (mm)	51 (2") and 19 (3/4")
Surface Inside	Plain steel or Unlined
Surface Outside	Painted with single color or multicolor, Decorated to top, bodies, and bottom
Weight (kg)	17.5

4 oil drums per pallet with secure packaging shall be provided and suitable for transportation. The pallet's dimension shall be 1.20 x 1.20 meters.

4. Acceptance Tests

The mineral insulating oil shall be tested to confirm all characteristics as specified. The number of samples examined for each item is shown in the attachment sheet No.1 and No.2. The oil will be accompanied with a statement form of the Bidder to guarantee its characteristics. EGAT shall have the right to reject all products if the samples do not pass the process of examination. EGAT shall test in some items (item 2.1, 2.3, 2.5-2.12, 2.14-2.15, 2.18-2.23, 2.25) and consider another item (item 2.2, 2.4, 2.13, 2.16, 2.17, 2.24) from product data sheet or technical data sheet of each company.

The sampling of mineral insulating oil shall be performed by the supplier and witnessed by EGAT with the sampling device and procedures according to ASTM D923 or IEC 60567. The supplier shall provide six dry and clean 1000 cc. glass bottles for each sampling

Sotajid Hirinam

-731.49-

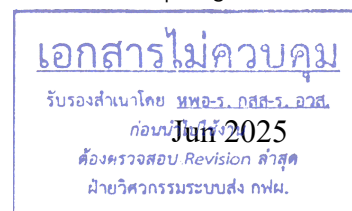

drum. In case of negative test results are from the sampling process or from the sampling device, the supplier shall take the responsibility.

The problem on sampling mineral insulating oil can be caused by unclean and wrong vessel during the sampling procedures so the supplier or trader must be informed of this regard.

The criteria for consideration of test result shall be performed as follows:

- The mineral insulating oil is submitted to EGAT by the supplier.
- When the samplings of mineral insulating oil are taken to test by EGAT and the test results do not become satisfactory, the supplier has to take the mineral insulating oil back immediately without any re-test. In other words, EGAT will perform the test without any charge to the supplier only. If EGAT does not satisfy with the result after the first testing, the suppliers shall take the mineral insulating oil back for improvement or change a new sampling and shall re-submit to EGAT only once. For the second submission, if the supplier wants EGAT to test the sampling again, he shall bear the testing cost as shown in attachment No.2 or if the supplier wants EGAT to send the sampling to be tested by the third party office accepted by EGAT, he shall bear for any cost that occurs.

5. Product Data Sheet or Technical Data Sheet and Test Report

Bidder shall submit, at the time of bidding, the product data sheet or the technical data sheet from the original maker, together with the latest test report of the proposed mineral insulating oil, according to the EGAT's requirement.

The approved vender shall inform, to EGAT, the number of lots or batches of the mineral insulating oil prior to submitting to be tested. The test report of each lot or batch shall be submitted with the product shipment.

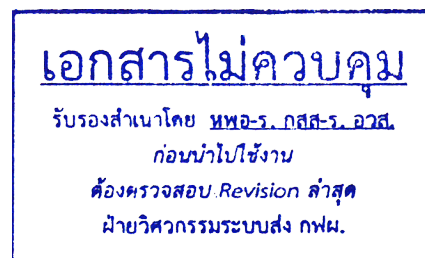

17 กุมภาพันธ์ 2569

Sotrasid Hirinmon