

## **EGAT's Privacy Notice on Procurement, Inventory Management and Contract Administration**

Electricity Generating Authority of Thailand (EGAT) has performed the protection of the Personal Data regarding procurement, inventory management and contract administration to be in accordance with the **Personal Data Protection Act B.E. 2562** (the "2019 PDPA"), which comes into effect on June 1, 2022.

Details about EGAT's Privacy Notice on Procurement, Inventory Management and Contract Administration are available for you at [https://www.egat.co.th/privacy-notice-procurement\\_en.html](https://www.egat.co.th/privacy-notice-procurement_en.html) or the below QR Code.



## **The Redaction of Sensitive Personal Data**

EGAT has announced the Privacy Notice on Procurement, Inventory Management and Contract Administration for the collection, use or disclosure of Personal Data, excluding the Sensitive Personal Data.

Should the documents you wish to submit to EGAT contain the Sensitive Personal Data as defined in Section 26 of the 2019 PDPA, pertaining to racial, ethnic origin, political opinions, cult, religious or philosophical beliefs, sexual behavior, criminal records, health data, disability, trade union information, genetic data, biometric data, or of any data which may affect you in the same manner, you shall redact or conceal such data before submitting to EGAT.

## ประกาศความเป็นส่วนตัว (Privacy Notice) สำหรับการจัดซื้อจัดจ้าง การบริหารพัสดุ และการบริหารสัญญาของ กฟผ.

การไฟฟ้าฝ่ายผลิตแห่งประเทศไทย (กฟผ.) ได้ดำเนินการคุ้มครองข้อมูลส่วนบุคคลสำหรับการจัดซื้อจัดจ้าง การบริหารพัสดุ และการบริหารสัญญา เพื่อให้เป็นไปตามพระราชบัญญัติคุ้มครองข้อมูลส่วนบุคคลของประเทศไทย พ.ศ. 2562 (PDPA) ซึ่งมีผลบังคับใช้อย่างครบถ้วน ตั้งแต่วันที่ 1 มิถุนายน 2565 ทั้งนี้ ท่านสามารถศึกษารายละเอียดประกาศความเป็นส่วนตัว (Privacy Notice) สำหรับการจัดซื้อจัดจ้าง การบริหารพัสดุ และการบริหารสัญญา ได้ที่ <https://www.egat.co.th/privacy-notice-procurement.html> หรือที่ QR Code ด้านล่าง



### การขิดฆ่าข้อมูลส่วนบุคคลอ่อนไหว

กฟผ. มีประกาศความเป็นส่วนตัว (Privacy Notice) สำหรับการจัดซื้อจัดจ้าง การบริหารพัสดุ และการบริหารสัญญา เพื่อใช้ในการเก็บรวบรวม ใช้ หรือเปิดเผย ข้อมูลส่วนบุคคล แต่ไม่เก็บข้อมูลส่วนบุคคลอ่อนไหว หากเอกสารของท่านที่ต้องส่งมอบให้ กฟผ. มีข้อมูลส่วนบุคคลอ่อนไหวตามที่ถูกบัญญัติไว้ในมาตรา 26 ของ PDPA ดังนี้ เชื้อชาติ เผ่าพันธุ์ ความคิดเห็นทางการเมือง ความเชื่อในลัทธิ ศาสนาหรือปรัชญา พฤติกรรมทางเพศ ประวัติอาชญากรรม ข้อมูลสุขภาพ ความพิการ ข้อมูลสหภาพแรงงาน ข้อมูลพันธุกรรม ข้อมูลชีวภาพ หรือข้อมูลอื่นใด ซึ่งกระทบต่อเจ้าของข้อมูลส่วนบุคคลในทำนองเดียวกันรวมอยู่ด้วย ขอให้ท่านขิดฆ่า หรือปกปิดข้อมูลดังกล่าว ก่อนส่งมอบให้แก่ กฟผ.

**1<sup>st</sup> Draft of Terms of Reference,  
Announcement and Details of Medium Cost  
for Invitation to Bid No. NPUP-MJ1-02 and LPLC-MJ1-01  
Supply of Instrument Transformer  
Transmission System Development in the Area of Nan Phrae and Uttaradit Provinces  
for Power Purchase from Lao PDR Projects  
Long-Term Investment Plan to Accommodate Large Power Consumer**

---

The Electricity Generating Authority of Thailand (EGAT) plans to call for proposals for the subject Invitation to Bid. Any person who has the authorization from the company, firm, joint venture or consortium who supplies or manufactures the equipment required under the subject invitation to Bid is allowed to submit a comment against the first draft of the Terms of Reference (TOR), the Announcement and the Details of Medium Cost attached herewith.

**How to Comment**

Those who would like to comment shall submit an official letter signed by the authorized person(s) together with the letter of authorization or the power of attorney, and addressed to “Chief, Procurement Department - Transmission System Segment, Central Procurement and Inventory Management Division”.

Comments shall be submitted via email address: [Tanatorn.Chokpaisarn@egat.co.th](mailto:Tanatorn.Chokpaisarn@egat.co.th) with all related documents attached (e.g. the letter of authorization and the power of attorney).

Comments shall be received by EGAT on or before **June 18, 2026**, Bangkok Standard Time, **otherwise the comments will not be taken into consideration.**

**EGAT reserves the right to change or not to change the terms and conditions contained in the Terms of Reference, the Announcement and the Details of Medium Cost subject to its consideration and such decision shall be final.**



Miss Benyalak Saralamba

Head, Procurement Section - Transmission System Segment 3

June 11, 2026

## Notice to Bidder

### Subject : Online Payment for Purchase of Bidding Documents

Please be informed of the online payment for purchase of bidding documents as follows:

- 1) Fill-out the Registration Form and the proof of payment in the link provided in <https://www4.egat.co.th/fprocurement/biddingeng>

Payment shall be made by bank transfer or telegraphic transfer to EGAT's account no. 109-6-01958-2 (swift code : KRTHTHBK), Krung Thai Bank Public Company Limited, Bangkruai Branch, Nonthaburi.

All bank charges and fees incurred by the payment of bidding documents shall be under the buyer's responsibility.

- 2) The registration will be deemed complete only upon successful processing of the payment and confirmation of funds received.
- 3) After the payment has been verified for approximately 3 working days, the in-charge officer will send the link for downloading the bidding documents together with the receipt to the purchaser's email address in the Registration Form.

\*\*\*\*\*



## Invitation to Bid No. NPUP-MJ1-02 and LPLC-MJ1-01

### Supply of Instrument Transformer

### Transmission System Development in the Area of Nan Phrae and Uttaradit Provinces for Power Purchase from Lao PDR Projects

### Long-Term Investment Plan to Accommodate Large Power Consumer

The Electricity Generating Authority of Thailand (EGAT) is calling for the subject Invitation to Bid to be financed by EGAT's fund.

**Place of Delivery** : Bangkok Port / Ex-works

**Medium Cost** (including Value Added Tax and other expenses) :

Description	Medium Cost (THB)
Schedules A1 and B2 : 500 kV Coupling Capacitor Voltage Transformer	13,700,000.-
Schedule A2 : 500 kV Inductive Voltage Transformer	5,310,000.-
Schedule B1 : 500 kV Current Transformer	20,500,000.-

#### **Eligibility of Bidders**

1. The Bidder shall be a juristic person who manufactures or provides such materials or services and shall not be named in the List of Work Abandoners published by the Permanent Secretary, Ministry of Finance, and/or in the Debarment List and/or in the List of Work Abandoners declared by EGAT.
2. The Bidder shall not be a Jointly Interested Bidder with other Bidders as from the date of EGAT's issuance of the Invitation, or shall not be a person who undertakes any action as an "Obstruction of Fair Price Competition" for this Invitation.
3. The Bidder shall not either be EGAT's consultant or involve in EGAT's consultancy company under this Invitation to Bid, or shall not have EGAT's personnel involved in his business as shareholder having voting right that can control his business, director, manager, officer, employee, agent, or consultant except those who are officially ordered by EGAT to act or participate therein.
4. The Bidder shall not be the person who is privileged or protected not to be taken any legal proceedings under Thai Court; Provided that such Bidder's government declares that such special privilege is waived.
5. The Bidder who is a joint venture or consortium shall carry out all the work under such formation from the time of bidding until the fulfillment of the Contract.

#### **Availability of Bidding Documents**

Bidding Documents are available for online purchase during 8:00 hrs. to 15:00 hrs., Bangkok Standard Time, as from \_\_\_\_\_ to \_\_\_\_\_ at USD 10.- or THB 300.- per copy, non-refundable.

Please find more details for online purchasing process at <http://www4.egat.co.th/fprocurement/biddingeng> or contact for further information at telephone no. 66 2436 0347 or [procurement.tse@egat.co.th](mailto:procurement.tse@egat.co.th).

#### **Delivery of Bids**

Bids shall be submitted at Bidding Room, 1<sup>st</sup> Floor, Tor 137 Building at EGAT's Head Office, Nonthaburi during 9:00 hrs. to 10:00 hrs., Bangkok Standard Time, \_\_\_\_\_ and will be opened publicly at 10:00 hrs.

ELECTRICITY GENERATING AUTHORITY OF THAILAND

(Date of Announcement)

(Miss Wallapa Chewadhnakor(kul)

Chief, Procurement Department – Transmission System Segment



## ประกาศการไฟฟ้าฝ่ายผลิตแห่งประเทศไทย

### เรื่อง ประกวดราคาซื้อ เลขที่ NPUP-MJ1-02 and LPLC-MJ1-01

การไฟฟ้าฝ่ายผลิตแห่งประเทศไทย (กฟผ.) มีความประสงค์จะซื้อ Instrument Transformer สำหรับโครงการพัฒนาระบบส่งไฟฟ้าบริเวณจังหวัด น่าน แพร่ และ อุตรดิตถ์ เพื่อรับซื้อไฟฟ้าจากโครงการใน สปป.ลาว และแผนลงทุนระยะยาวเพื่อรองรับกลุ่มผู้ใช้ไฟฟ้าขนาดใหญ่ โดยใช้งบประมาณ กฟผ.

**สถานที่ส่งมอบ** : ท่าเรือกรุงเทพฯ / หน้าโรงงานผู้ผลิต

**ราคากลาง (รวมภาษีมูลค่าเพิ่มและค่าใช้จ่ายอื่นๆ) :**

รายการ	ราคากลาง (บาท)
Schedules A1 and B2 : 500 kV Coupling Capacitor Voltage Transformer	13,700,000.-
Schedule A2 : 500 kV Inductive Voltage Transformer	5,310,000.-
Schedule B1 : 500 kV Current Transformer	20,500,000.-

#### คุณสมบัติของผู้เสนอราคา

- ต้องเป็นนิติบุคคลผู้ผลิตหรือเป็นผู้มีอาชีพขายพัสดุตามประกาศ และต้องไม่เป็นผู้ทำงานซึ่งปลัดกระทรวงการคลังได้แจ้งเวียนชื่อไว้ หรือต้องไม่เป็นผู้ที่ กฟผ. ห้ามติดต่อหรือห้ามเข้าเสนอราคา หรือต้องไม่เป็นผู้ที่ได้รับผลของการสั่งให้นิติบุคคลหรือบุคคลอื่นเป็นผู้ทำงานตามคำสั่ง กฟผ.
- ต้องไม่เป็นผู้มีผลประโยชน์ร่วมกันกับผู้เสนอราคารายอื่น ณ วันประกาศประกวดราคาครั้งนี้เป็นต้นไป หรือต้องไม่เป็นผู้กระทำการอันเป็นการขัดขวางการแข่งขันราคาอย่างเป็นธรรมในการดำเนินการประกวดราคาครั้งนี้
- ต้องไม่เป็นที่ปรึกษาของ กฟผ. หรือมีส่วนร่วมในบริษัทที่ปรึกษาของ กฟผ. ในงานนี้ หรือต้องไม่มีผู้ปฏิบัติงาน กฟผ. เข้าไปมีส่วนร่วมในกิจการของผู้เสนอราคา ไม่ว่าจะในฐานะผู้ถือหุ้นที่มีสิทธิควบคุมการจัดการ กรรมการ ผู้อำนวยการ ผู้จัดการ พนักงาน ลูกจ้าง ตัวแทนหรือที่ปรึกษา ยกเว้น ในกรณีที่ผู้ปฏิบัติงานได้รับคำสั่งอย่างเป็นทางการจาก กฟผ. ให้ไปปฏิบัติงานหรือเข้าร่วมในกิจการของผู้เสนอราคา
- ต้องไม่เป็นผู้ได้รับเอกสิทธิ์หรือความคุ้มกัน ซึ่งอาจปฏิเสธไม่ยอมขึ้นศาลไทย เว้นแต่รัฐบาลของผู้เสนอราคาได้มีคำสั่งให้ละสิทธิ์และความคุ้มกันเช่นนั้น
- ผู้ประสงค์เข้าประกวดราคาในนามของกิจการร่วมค้าหรือกิจการร่วม (Joint Venture or Consortium) จะต้องดำเนินการทุกขั้นตอนของการประกวดราคาในนามของกิจการร่วมค้าหรือกิจการร่วม ตั้งแต่การเสนอราคาจนสิ้นสุดข้อผูกพันกับ กฟผ.

#### การขายเอกสารประกวดราคา

ผู้สนใจติดต่อซื้อเอกสารประกวดราคา ในราคาชุดละ 300.- บาท ในวันทำการระหว่างเวลา 08:00 น. ถึง 15:00 น. ตั้งแต่วันที่ \_\_\_\_\_ ถึงวันที่ \_\_\_\_\_ ทั้งนี้ สามารถดูรายละเอียดการซื้อเอกสารประกวดราคาได้ที่เว็บไซต์ <http://www4.egat.co.th/fprocurement/biddingeng> หรือสอบถามข้อมูลเพิ่มเติมได้ทางโทรศัพท์ หมายเลข 0 2436 0347 หรืออีเมล [procurement.tse@egat.co.th](mailto:procurement.tse@egat.co.th)

#### การยื่นซองประกวดราคา

กำหนดยื่นซองประกวดราคา ในวันที่ \_\_\_\_\_ เวลา 09:00 น. ถึง 10:00 น. และเปิดซองประกวดราคาเวลา 10:00 น. ณ ห้องประกวดราคา ชั้น 1 อาคาร ท.137 การไฟฟ้าฝ่ายผลิตแห่งประเทศไทย เซิงสะพานพระราม 7 จังหวัดนนทบุรี

ประกาศ ณ วันที่ \_\_\_\_\_

(นางสาววัลลภา ชีวธนากรณกุล)

หัวหน้ากองจัดซื้อจัดจ้างสายงานระบบส่ง

ตารางแสดงวงเงินงบประมาณที่ได้รับจัดสรรและราคากลาง(ราคาอ้างอิง)  
ในการจัดซื้อจัดจ้างที่มีใช้งานก่อสร้าง

1. ชื่อโครงการ Bid No. NPUP-MJ1-02 and LPLC-MJ1-01  
งานจัดซื้อ Instrument Transformer  
โครงการพัฒนาระบบส่งไฟฟ้าบริเวณจังหวัด น่าน แพร่ และ อุตรดิตถ์ เพื่อรับซื้อไฟฟ้า  
จากโครงการใน สปป.ลาว  
แผนลงทุนระยะยาวเพื่อรองรับกลุ่มผู้ใช้ไฟฟ้าขนาดใหญ่  
หน่วยงานเจ้าของโครงการ ฝ่ายแผนงานและโครงการระบบส่ง การไฟฟ้าฝ่ายผลิตแห่งประเทศไทย
2. วงเงินงบประมาณที่ได้รับจัดสรร  
โครงการพัฒนาระบบส่งไฟฟ้าบริเวณจังหวัด น่าน แพร่ และ อุตรดิตถ์ เพื่อรับซื้อไฟฟ้า  
จากโครงการใน สปป.ลาว งบประมาณ 26,220 ล้านบาท  
แผนลงทุนระยะยาวเพื่อรองรับกลุ่มผู้ใช้ไฟฟ้าขนาดใหญ่ งบประมาณ 1,570 ล้านบาท
3. วันที่กำหนดราคากลาง 21 เมษายน 2569 (วันที่ อวส. อนุมัติ)  
ราคารวมภาษีมูลค่าเพิ่มและค่าใช้จ่ายอื่นๆ เป็นเงิน 39,510,000.00 ราคา/หน่วย ตามเอกสารแนบ
4. แหล่งที่มาของราคากลาง  
หลักเกณฑ์การกำหนดราคากลางการจัดซื้อและจัดจ้างงานก่อสร้างระบบส่งไฟฟ้าของสายงานพัฒนาระบบส่ง
5. รายชื่อเจ้าหน้าที่ผู้กำหนดราคากลาง
  - 5.1 นายณัฐ วงศ์เทพวณิชย์ หมพ-ร., กวอ-ร.
  - 5.2 นางสาวกาญจนา ผลสวัสดิ์ วศ.7, หมพ-ร., กวอ-ร.

หมายเหตุ ค่าใช้จ่ายอื่นๆ ได้แก่ ค่าใช้จ่ายที่ กฟผ. ต้องจ่ายตามวิธีการพิจารณาเปรียบเทียบราคาที่กำหนดไว้  
ในเอกสารประกวดราคา เช่น อกรขาเข้า เป็นต้น

## MEDIUM COST FOR BID NO. NPUP-MJ1-02 and LPLC-MJ1-01

## SUMMARY OF BID PRICE

## SUPPLY OF INSTRUMENT TRANSFORMER

TRANSMISSION SYSTEM DEVELOPMENT IN THE AREA OF NAN PHRAE AND UTTARADIT PROVINCES FOR POWER PURCHASE FROM LAO PDR PROJECTS  
LONG-TERM INVESTMENT PLAN TO ACCOMMODATE LARGE POWER CONSUMER

No.	Description	Currency	Supply of Equipment	
			Foreign Supply	Local Supply
			CFR Thai Port	Ex-works Price ( excluding VAT ) Baht
			Amount	Amount
1	Schedule A1 : 500 kV Coupling Capacitor Voltage Transformer	THB	7,541,556.00	529,140.00
2	Schedule B2 : 500 kV Coupling Capacitor Voltage Transformer	THB	4,399,241.00	308,665.00
<b>BID PRICE</b>		THB	11,940,797.00	Baht 837,805.00
<b>IMPORT DUTY (0%)</b>		THB		Baht
<b>CUSTOM CLEARANCE</b>		THB	71,644.78	Baht
<b>VAT</b>		THB	835,855.79	Baht 58,646.35
<b>TOTAL MEDIUM COST</b>		THB	13,744,748.92	
<b>TOTAL MEDIUM COST (ROUND)</b>		THB	13,700,000.00	

  
 นายสมชัย เจริญศรีเกษม  
 ผู้อำนวยการฝ่ายวิศวกรรมระบบส่ง

**MEDIUM COST FOR BID NO. NPUP-MJ1-02 and LPLC-MJ1-01**

**SUMMARY OF BID PRICE**

**SUPPLY OF INSTRUMENT TRANSFORMER**

**TRANSMISSION SYSTEM DEVELOPMENT IN THE AREA OF NAN PHRAE AND UTTARADIT PROVINCES FOR POWER PURCHASE FROM LAO PDR PROJECTS  
LONG-TERM INVESTMENT PLAN TO ACCOMMODATE LARGE POWER CONSUMER**

No.	Description	Currency	Supply of Equipment	
			Foreign Supply	Local Supply
			CFR Thai Port	Ex-works Price (excluding VAT) Baht
			Amount	Amount
1	Schedule A2 : 500 kV Inductive Voltage Transformer	THB	4,673,556.00	264,570.00
<b>BID PRICE</b>		THB	4,673,556.00	Baht 264,570.00
<b>IMPORT DUTY (0%)</b>		THB		Baht
<b>CUSTOM CLEARANCE</b>		THB	28,041.34	Baht
<b>VAT</b>		THB	327,148.92	Baht 18,519.90
<b>TOTAL MEDIUM COST</b>		THB	5,311,836.16	
<b>TOTAL MEDIUM COST (ROUND)</b>		THB	5,310,000.00	

นายสมชัย เจริญศรีเกษม  
ผู้อำนวยการฝ่ายวิศวกรรมระบบส่ง

21 Apr 2026

**MEDIUM COST FOR BID NO. NPUP-MJ1-02 and LPLC-MJ1-01**

**SUMMARY OF BID PRICE**

**SUPPLY OF INSTRUMENT TRANSFORMER**

**TRANSMISSION SYSTEM DEVELOPMENT IN THE AREA OF NAN PHRAE AND UTTARADIT PROVINCES FOR POWER PURCHASE FROM LAO PDR PROJECTS  
LONG-TERM INVESTMENT PLAN TO ACCOMMODATE LARGE POWER CONSUMER**

No.	Description	Currency	Supply of Equipment	
			Foreign Supply	Local Supply
			CFR Thai Port	Ex-works Price (excluding VAT) Baht
			Amount	Amount
1	Schedule B1 : 500 kV Current Transformer	THB	18,424,008.00	617,328.00
<b>BID PRICE</b>		THB	18,424,008.00	Baht 617,328.00
<b>IMPORT DUTY (0%)</b>		THB		Baht
<b>CUSTOM CLEARANCE</b>		THB	110,544.05	Baht
<b>VAT</b>		THB	1,289,680.56	Baht 43,212.96
<b>TOTAL MEDIUM COST</b>		THB	20,484,773.57	
<b>TOTAL MEDIUM COST (ROUND)</b>		THB	20,500,000.00	



นายสมชัย เจริญศรีเกษม  
ผู้อำนวยการฝ่ายวิศวกรรมระบบส่ง

**MEDIUM COST FOR BID NO. NPUP-MJ1-02 and LPLC-MJ1-01**

**Schedule A1 : 500 kV Coupling Capacitor Voltage Transformer**

**SUPPLY OF INSTRUMENT TRANSFORMER**

**TRANSMISSION SYSTEM DEVELOPMENT IN THE AREA OF NAN PHRAE AND UTTARADIT PROVINCES FOR POWER PURCHASE FROM LAO PDR PROJECTS**

Item No.	Description	Qty.	Unit	Currency	Supply of Equipment				Supply of Equipment	
					Foreign Supply				Local Supply	
					FOB Vessel	Cost of Transportation to Thai Port	CFR Thai Port		Ex-works Price (excluding VAT) Baht	
					Unit Price	Unit Price	Unit Price	Amount	Unit Price	Amount
A1-1	525 kV CCVT, 525000/√3 : 120/(120/√3) & 120/(120/√3) & 120/(120/√3) V, with carrier accessories, oil filled as per ratings and features RF PD9W1A	6		THB	628,463.00		628,463.00	3,770,778.00		
A1-2	525 kV CCVT, 525000/√3 : 120/(120/√3) & 120/(120/√3) & 120/(120/√3) & 120/(120/√3) V, with carrier accessories, oil filled as per ratings and features RF PD9W1B	6		THB	628,463.00		628,463.00	3,770,778.00		
A1-3	Steel Supporting Structure for PD9W1A (for item no.A1-1), H = 9.00 m. as per Dwg. No. ST-VT-9-01 and SD-AB-0-01	6			XXXXXX	XXXXXX	XXXXXX	XXXXXX	44,095.00	264,570.00
A1-4	Steel Supporting Structure for PD9W1B (for item no.A1-2), H = 9.00 m. as per Dwg. No. ST-VT-9-01 and SD-AB-0-01	6			XXXXXX	XXXXXX	XXXXXX	XXXXXX	44,095.00	264,570.00
	Equipment which shall be used together as a complete set referring to Article relevant to Liquidated Damages for Late Delivery of Equipment are item nos. A1-1 with A1-3 and A1-2 with A1-4									
<b>Total Price for Schedule A1</b>					<b>THB</b>		<b>7,541,556.00</b>	<b>Baht</b>	<b>529,140.00</b>	



นายสมชัย เจริญศรีเกษม  
ผู้อำนวยการฝ่ายวิศวกรรมระบบส่ง

21 Apr 2026

**MEDIUM COST FOR BID NO. NPUP-MJ1-02 and LPLC-MJ1-01**

**Schedule A2 : 500 kV Inductive Voltage Transformer**

**SUPPLY OF INSTRUMENT TRANSFORMER**

**TRANSMISSION SYSTEM DEVELOPMENT IN THE AREA OF NAN PHRAE AND UTTARADIT PROVINCES FOR POWER PURCHASE FROM LAO PDR PROJECTS**

Item No.	Description	Qty.	Unit	Currency	Supply of Equipment				Supply of Equipment		
					Foreign Supply				Local Supply		
					FOB Vessel	Cost of Transportation to Thai Port	CFR Thai Port		Ex-works Price (excluding VAT) Baht		
Unit Price	Unit Price	Unit Price	Amount	Unit Price	Amount						
A2-1	525 kV VT, 525000/√3 : 120/(120/√3) & 120/(120/√3) & 110 V, oil filled as per ratings and features RF VT901A	6		THB	778,926.00		778,926.00	4,673,556.00			
A2-2	Steel Supporting Structure for VT901A (for item no.A2-1), H = 9.00 m. as per Dwg. No. ST-VT-9-01 and SD-AB-0-01	6			XXXXXX	XXXXXX	XXXXXX	XXXXXX	44,095.00	264,570.00	
	Equipment which shall be used together as a complete set referring to Article relevant to Liquidated Damages for Late Delivery of Equipment are item nos. A2-1 with A2-2										
<b>Total Price for Schedule A2</b>				<b>THB</b>	<b>4,673,556.00</b>				<b>Baht</b>	<b>264,570.00</b>	

  
 นายสมชัย เจริญศรีเกษม  
 ผู้อำนวยการฝ่ายวิศวกรรมระบบส่ง

21 Apr 2026

**MEDIUM COST FOR BID NO. NPUP-MJ1-02 and LPLC-MJ1-01**

**Schedule B1 : 500 kV Current Transformer**

**SUPPLY OF INSTRUMENT TRANSFORMER**

**LONG-TERM INVESTMENT PLAN TO ACCOMMODATE LARGE POWER CONSUMER**

Item No.	Description	Qty.	Unit	Currency	Supply of Equipment				Supply of Equipment		
					Foreign Supply				Local Supply		
					FOB Vessel	Cost of Transportation to Thai Port	CFR Thai Port		Ex-works Price (excluding VAT) Baht		
Unit Price	Unit Price	Unit Price	Amount	Unit Price	Amount						
B1-1	550 kV CT, 2000-3000-4000/1A (6 cores), 50 kA, oil filled as per Rating and Features RF CT9AFAI	6		THB	1,535,334.00		1,535,334.00	9,212,004.00			
B1-2	550 kV CT, 2000-3000-4000/1A (6 cores), 50 kA, oil filled as per Rating and Features RF CT9AFDI	6		THB	1,535,334.00		1,535,334.00	9,212,004.00			
B1-3	Steel Supporting Structure for CT9AFAI (for item no.B1-1), H = 9.00 m. as per Dwg. No. ST-CT-9-01 and SD-AB-0-01	6			XXXXXX	XXXXXX	XXXXXX	XXXXXX	51,444.00	308,664.00	
B1-4	Steel Supporting Structure for CT9AFDI (for item no.B1-2), H = 9.00 m. as per Dwg. No. ST-CT-9-01 and SD-AB-0-01	6			XXXXXX	XXXXXX	XXXXXX	XXXXXX	51,444.00	308,664.00	
	Equipment which shall be used together as a complete set referring to Article relevant to Liquidated Damages for Late Delivery of Equipment are item nos. B1-1 with B1-3 and B1-2 with B1-4										
				<b>THB</b>	<b>18,424,008.00</b>				<b>Baht</b>	<b>617,328.00</b>	
<b>Total Price for Schedule B1</b>											

  
 นายสมชัย เจริญศรีเกษม  
 ผู้อำนวยการฝ่ายวิศวกรรมระบบส่ง  
 21 Apr 2026

**MEDIUM COST FOR BID NO. NPUP-MJ1-02 and LPLC-MJ1-01**

**Schedule B2 : 500 kV Coupling Capacitor Voltage Transformer**

**SUPPLY OF INSTRUMENT TRANSFORMER**

**LONG-TERM INVESTMENT PLAN TO ACCOMMODATE LARGE POWER CONSUMER**

Item No.	Description	Qty.	Unit	Currency	Supply of Equipment				Supply of Equipment		
					Foreign Supply				Local Supply		
					FOB Vessel	Cost of Transportation to Thai Port	CFR Thai Port		Ex-works Price (excluding VAT) Baht		
					Unit Price	Unit Price	Unit Price	Amount	Unit Price	Amount	
B2-1	525 kV CCVT, 525000/√3 : 120/(120/√3) & 120/(120/√3) & 120/(120/√3) V, with carrier accessories, oil filled as per ratings and features RF PD9W1A	7		THB	628,463.00		628,463.00	4,399,241.00			
B2-2	Steel Supporting Structure for PD9W1A (for item no.B2-1), H = 9.00 m. as per Dwg. No. ST-VT-9-01 and SD-AB-0-01	7			XXXXXX	XXXXXX	XXXXXX	XXXXXX	44,095.00	308,665.00	
	Equipment which shall be used together as a complete set referring to Article relevant to Liquidated Damages for Late Delivery of Equipment are item nos. B2-1 with B2-2										
<b>Total Price for Schedule B2</b>				<b>THB</b>	<b>4,399,241.00</b>				<b>Baht</b>	<b>308,665.00</b>	



นายสมชัย เจริญศรีเกษม  
ผู้อำนวยการฝ่ายวิศวกรรมระบบส่ง

21 Apr 2026

**Contract No.**

**Invitation to Bid No. NPUP-MJ1-02  
and LPLC-MJ1-01**

---

**ELECTRICITY GENERATING AUTHORITY OF THAILAND**



**BIDDING DOCUMENTS**

**SUPPLY OF INSTRUMENT TRANSFORMER**

**TRANSMISSION SYSTEM DEVELOPMENT IN THE AREA OF  
NAN PHRAE AND UTTARADIT PROVINCES FOR  
POWER PURCHASE FROM LAO PDR PROJECTS**

**LONG-TERM INVESTMENT PLAN TO ACCOMMODATE  
LARGE POWER CONSUMER**

**EGAT'S FUND**

---

**BIDDER :** \_\_\_\_\_

---

(2026)

**INVITATION TO BID NO. NPUP-MJ1-02 and LPLC-MJ1-01**

**SUPPLY OF INSTRUMENT TRANSFORMER**

**TRANSMISSION SYSTEM DEVELOPMENT IN THE AREA OF NAN PHRAE AND  
UTTARADIT PROVINCES FOR POWER PURCHASE FROM LAO PDR PROJECTS**

**LONG-TERM INVESTMENT PLAN TO ACCOMMODATE  
LARGE POWER CONSUMER**

**EGAT'S FUND**

---

**CONTENTS**

CONFIRMATION FORM

DISCOUNT FORM

ADDITIONAL REGULATION

IMPORTANT INFORMATION

DATA SHEET

SECTION A INVITATION TO BID

SECTION B INSTRUCTIONS TO BIDDERS

SECTION C PROPOSAL

SECTION D CONTRACT

SECTION E GENERAL CONDITIONS

SECTION F SPECIAL CONDITIONS

SECTION G RATINGS AND FEATURES

SECTION H BILL OF MATERIALS (None)

SECTION I SPECIFICATIONS

SECTION J DRAWINGS

## CONTENTS

<u>Article No.</u>	<u>Description</u>	<u>Page</u>
	Confirmation Form	-
	Discount Form	-
	Additional Regulation	1-11
	Important Information	i
	Data Sheet	i
 <b>SECTION A : <u>INVITATION TO BID</u></b> 		
A-1	Invitation	A1
A-2	Eligibility of Bidders: General Requirements	A1
A-3	Eligibility of Bidders: Technical Requirements	A2
A-4	Joint Venture or Consortium	A4
A-5	Preparation and Delivery of Bids	A5
A-6	Availability of Bidding Documents	A6
 <b>SECTION B : <u>INSTRUCTIONS TO BIDDERS</u></b> 		
	Overview of the Procurement Process	B1
B-1	Preparation of Bids	B2
B-2	Bid Prices	B3
B-3	Bid Security	B5
B-4	Validity of Bids	B6
B-5	Delivery of Bids	B6
B-6	Withdrawal of Bids	B6
B-7	Interpretation of Bidding Documents before Bid Opening	B6
B-8	Information to be Submitted with Bid	B7

<u>Article No.</u>	<u>Description</u>	<u>Page</u>
B-9	Deviations from Specifications	B9
B-10	Rejection of Bids	B9
B-11	Delivery Time	B9
B-12	Evaluation and Comparison of Bids	B10
B-13	Acceptance of Bids	B11
B-14	Appeal	B11
B-15	Award of Contract	B12
B-16	Bidder's Responsibility	B12
B-17	Supplemental Notices	B12
B-18	Cost of Bidding	B13
B-19	Cancellation of Bid	B13
	Specimen of Bid Security	B14
<b>SECTION C : <u>PROPOSAL</u></b>		
C-1	Price Schedule	C1
C-2	Penalty for Equipment Not Meeting Guaranteed Characteristics	C2
C-3	Guaranteed Delivery Time	C2
C-4	Drawing and Document Submission Schedule	C2
C-5	Estimate of Deliveries	C2
C-6	Bid Security	C3
C-7	Supplemental Notices	C3
	Part 1 : Price Proposal	Part 1-C1
	Part 2 : Proposal Data	Part 2-C1
	Part 3 : Delivery Schedule and Distribution List	Part 3-C1

<u>Article No.</u>	<u>Description</u>	<u>Page</u>
--------------------	--------------------	-------------

**SECTION D : CONTRACT**

D-1	Contract Documents	D1
D-2	Acceptance of Proposal	D2
D-3	Agreement	D2
D-4	Obligation of Contractor	D2
D-5	Obligation of EGAT	D2
D-6	Mutual Obligations	D3
D-7	Deposit of Performance Security	D3
D-8	Assignment	D3
D-9	Notices	D3
D-10	Integration	D4
D-11	Counterpart	D4

**SECTION E : GENERAL CONDITIONS**

E-1	Definitions	E1
E-2	Intent of Contract Documents	E2
E-3	Applicable Law and Legal Jurisdiction	E3
E-4	Statutory Requirements	E3
E-5	Patents and Copyrights	E3
E-6	Subcontracts	E4
E-7	Export Charges	E4
E-8	Import Duty and Taxes	E4
E-9	Value Added Tax	E5
E-10	Income and Other Taxes	E6

<u>Article No.</u>	<u>Description</u>	<u>Page</u>
E-11	Fees and Duties	E7
E-12	Performance Security	E8
E-13	Inspection and Tests	E9
E-14	Preparation for Shipment and/or Delivery	E11
E-15	Clearance and Weight Limitations	E13
E-16	Shipment	E13
E-17	Documents Required for Each Shipment	E15
E-18	Force Majeure	E18
E-19	Transportation Insurance	E19
E-20	Transfer of Title	E19
E-21	Changes and Extra or Omitted Work	E19
E-22	Termination and Suspension of Contract	E20
E-23	Default and Termination	E20
E-24	Indemnification by the Contractor	E21
E-25	Limitation of Liability	E22
E-26	Consequential Damages	E22
E-27	Vesting of Contract in Receiver	E22
E-28	Extension of Time	E23
E-29	Failure to Meet Requirements	E23
E-30	Operation or Use of Unsatisfactory Equipment	E26
E-31	Dispute Resolution	E26
E-32	Language and Numbers	E26
	Specimen of Guarantee	E27
	Instructions for Packaging	E28

<u>Article No.</u>	<u>Description</u>	<u>Page</u>
--------------------	--------------------	-------------

**SECTION F : SPECIAL CONDITIONS**

F-1	Scope of Work	F1
F-2	Responsibility of Contractor	F1
F-3	Cooperation with Other Contractors	F1
F-4	Supervision of Installation	F2
F-5	Acceptance Tests	F3
F-6	Failure to Meet Performance Guarantees	F3
F-7	Acceptance Certificate	F3
F-8	Payment	F4
F-9	Liquidated Damages for Late Delivery of Equipment	F8
F-10	Maintenance Guarantee	F9
F-11	Drawings and Documents to be Furnished by Contractor	F11
F-12	Maintenance Security	F14
	Specimen of Maintenance Guarantee	F16
	Drawings and Documents to be Furnished by the Contractor (For Control and Protection Equipment)	F17
	Drawings and Documents to be Furnished by the Contractor (For All Equipment except Control and Protection Equipment)	F18

**SECTION G : RATINGS AND FEATURES**

G-1	Ratings and Features	G1
-----	----------------------	----

**SECTION H : BILL OF MATERIALS (None)**

- - -

<u>Article No.</u>	<u>Description</u>	<u>Page</u>
--------------------	--------------------	-------------

**SECTION I : SPECIFICATIONS**

I-1	Specifications	I1
-----	----------------	----

**SECTION J : DRAWINGS**

J-1	Drawings	J1
-----	----------	----

DRAFT

**CONFIRMATION FORM**

**(INDIVIDUAL COMPANY / JOINT VENTURE)**

**INVITATION TO BID NO. NPUP-MJ1-02 and LPLC-MJ1-01**

**SUPPLY OF INSTRUMENT TRANSFORMER**

**TRANSMISSION SYSTEM DEVELOPMENT IN THE AREA OF NAN PHRAE AND  
UTTARADIT PROVINCES FOR POWER PURCHASE FROM LAO PDR PROJECTS**

**LONG-TERM INVESTMENT PLAN TO ACCOMMODATE  
LARGE POWER CONSUMER**

By signing in the space provided below, we confirm that:-

- According to “Eligibility of Bidders” and in addition to the Documentary List attached to the bidding documents, we are not a Jointly Interested Bidder with the other bidders as from the date of EGAT’s issuance of the subject Invitation and are not a person who undertakes any actions as an “Obstruction of Fair Price Competition”.
- According to Article B-8 Information to be Submitted with Bid, we confirm
  - Registration with the Revenue Department as a value added tax registrant in Thailand as per certificate of value added tax registration (ภพ.20) attached.
  - Non-Registration as a value added tax registrant in Thailand, but will register later.
  - Non-Registration as a value added tax registrant in Thailand and will not register.

Confirmed :

.....

By : .....

Title : .....

Date : .....

**CONFIRMATION FORM**

**(CONSORTIUM)**

**INVITATION TO BID NO. NPUP-MJ1-02 and LPLC-MJ1-01**

**SUPPLY OF INSTRUMENT TRANSFORMER**

**TRANSMISSION SYSTEM DEVELOPMENT IN THE AREA OF NAN PHRAE AND  
UTTARADIT PROVINCES FOR POWER PURCHASE FROM LAO PDR PROJECTS**

**LONG-TERM INVESTMENT PLAN TO ACCOMMODATE  
LARGE POWER CONSUMER**

---

**Member No. ... of the consortium:**

By signing in the space provided below, we confirm that:-

- According to “Eligibility of Bidders” and in addition to the Documentary List attached to the bidding documents, we are not a Jointly Interested Bidder with the other bidders as from the date of EGAT’s issuance of the subject Invitation and are not a person who undertakes any actions as an “Obstruction of Fair Price Competition”.
- According to Article B-8 Information to be Submitted with Bid, we confirm
  - Registration with the Revenue Department as a value added tax registrant in Thailand as per certificate of value added tax registration (จพ.20) attached.
  - Non-Registration as a value added tax registrant in Thailand, but will register later.
  - Non-Registration as a value added tax registrant in Thailand and will not register.

Confirmed :

.....

By : .....

Title : .....

Date : .....

**DISCOUNT FORM**  
***(Excluding VAT)***

**INVITATION TO BID NO. NPUP-MJ1-02 and LPLC-MJ1-01**

**SUPPLY OF INSTRUMENT TRANSFORMER**

**TRANSMISSION SYSTEM DEVELOPMENT IN THE AREA OF NAN PHRAE AND  
UTTARADIT PROVINCES FOR POWER PURCHASE FROM LAO PDR PROJECTS**

**LONG-TERM INVESTMENT PLAN TO ACCOMMODATE  
LARGE POWER CONSUMER**

**Bidder :** \_\_\_\_\_

By signing in the space provided below, we confirm that:-

- we offer no discount.
- we offer discount(s) as follows:

Details of discount	Currency	Amount

Remarks :

- ***The Bidder shall apply discount(s) on any item(s), schedule(s), or the total price, excluding Value Added Tax (VAT).***
- The above discount(s) shall not be subject to any conditions. Discount with conditions shall not be considered.
- This Discount Form, together with Bidder's Summary of Bid Price, will be publicly presented on a screen to all Bidders in the bid opening room at the time of bid opening.

Confirmed by authorized person(s):

.....

By : .....

Title : .....

Date : .....

## Additional Regulation

This Regulation shall apply to the Enquiry, Bid for Supply, Lease, Hire of Work, or Hire of Consultant by Way of Selection.

1. Attachments
  - 1.1 Definitions
    - 1.1.1 Jointly Interested Bidder
    - 1.1.2 Obstruction of Fair Price Competition
  - 1.2 Documentary List
2. Bidder's Qualifications
  - 2.1 The Bidder shall professionally be in the business of providing materials or services or leasing or consultancy services, as the case may be, and shall not be named in the list of work abandoners published by the Permanent Secretary, Ministry of Finance, and/or in the debarment list and/or the list of work abandoners declared by EGAT according to Article 5 of this Regulation.
  - 2.2 The Bidder shall not be a Jointly Interested Bidder with other bidders as from the date of EGAT's issuance of the Invitation for Bid/Enquiry or the Invitation Letter/ Terms of Reference for the consultancy services, as the case may be, or shall not be a person who undertakes any action as an "Obstruction of Fair Price Competition" described in Article 1.1 – Definitions.
  - 2.3 The Bidder shall not have EGAT's personnel involve in his business as shareholder having voting right that can control his business, director, manager, officer, employee, agent or consultant except for the ones who are officially ordered by EGAT to act or participate therein.
3. Information to be Submitted with Bid

The Bidder shall submit with his bid the documents according to Article 1.2 - Documentary List, including but not limited to, the following documents :-

  - 3.1 Where the Bidder is a juristic person :
    - (a) ordinary partnership or limited partnership

a certified copy of affidavit of incorporation, name list of managing partners, list of persons entrusted with controlling power (if any), as well as a certified copy of registration for value added tax (if any).
    - (b) limited company or public limited company

a certified copy of affidavit of incorporation, memorandum of association, name list of managing directors, list of persons entrusted with controlling power (if any) and name list of major shareholders, as well as a certified copy of registration for value added tax (if any).

Such certified copy of affidavit of incorporation with the validity of not more than six (6) months from the date of certification to the opening date of Bid/Enquiry or the date of Invitation Letter/Terms of Reference in case of consultancy services, as the case may be, shall certify at least the following information :

- (i) Type of a juristic person : an ordinary partnership, a limited partnership, a limited company, a public limited company,
- (ii) Name according to (i),
- (iii) Number and names of managing partners or managing directors,
- (iv) Number and names of managing partners or managing directors authorized to act on behalf of the company,
- (v) Amount of shareholders' equity or registered capital,
- (vi) Authority of managing partner in case of partnership,
- (vii) Location of head office,
- (viii) Registration purposes,
  
- (ix) Scope of work indicated in business permit license of a foreign juristic person who registers in Thailand,
- (x) Other documents e.g. changes or additions to the above documents, branches (if any).

3.2 Where the Bidder is a natural person or a group of persons other than a juristic person :

a certified copy of :

- identity card **or passport (if non-Thai national)**
- partnership agreement or contract (if any)
- partners' identity cards **or passport (if non-Thai national)**
- registration required by Ministry of Commerce of Thailand
- registration for value added tax (if any)

3.3 Where the Bidder is a joint venture / consortium :

a certified copy of :

- association agreement
- identity card or passport (if non Thai national)  
(The participant in the joint venture or consortium is not a juristic person.)
- all documents specified in *Item 3.1* of Additional Regulation  
(The participant in the joint venture or consortium is a juristic person.)

3.4 Other documentary evidence as required per *Item 3, 6 or 8* of Documentary List (if any).

4. Preliminary Examination

4.1 EGAT shall examine the qualification of all bidders to determine whether any bidder is a Jointly Interested Bidder as from the date of EGAT's issuance of the Invitation for Bid/Enquiry or the Invitation Letter/Terms of Reference for the consultancy services, as the case may be, and/or undertakes any action as an "Obstruction of Fair Price Competition" before or during the bid opening. If there is evidence showing that any bidder is a Jointly Interested Bidder or undertakes any action as an "Obstruction of Fair Price Competition", EGAT shall delete his name from the list of bidders and inform such bidder by written notice hereof.

4.2 The Bidder whose name is deleted according to Article 4.1, may, within fifteen (15) calendar days from the date of receipt of EGAT's written notice, appeal to EGAT, explaining reasons together with relevant documents for EGAT's reconsideration.

In case EGAT agrees with the objection of the appellant but considers that the cancellation of enquiry/bidding will be beneficial to EGAT, EGAT may, at its sole discretion, cancel such bid. In the event that the Bidder who undertakes any action as an "Obstruction of Fair Price Competition" does not appeal or, after his appeal, EGAT does not agree with his objection, such Bidder shall be regarded as a work abandoner.

EGAT's decision shall be notified to the appellant in writing and such decision shall be final and conclusive.

5. Reservation of the Right for Proposal and Others

In case any juristic person is regarded as a work abandoner by EGAT and such abandonment is caused by the manager, the managing partner, the managing director, the executive or the person authorized to manage the business of that juristic person, EGAT shall also include his name as a work abandoner.

In case any juristic person is regarded as a work abandoner by EGAT, such decision shall also be applied to other juristic persons of the same business where its manager, managing partner, managing director, executive, or person authorized to manage the business is the same person who is the manager, managing partner, managing director, executive, or person authorized to manage the business of the juristic person who is regarded as a work abandoner by EGAT as aforesaid.

In case any natural person is regarded as a work abandoner by EGAT, such decision shall also be applied to other juristic persons who submit the proposal and have such natural person as the manager, managing partner, managing director, executive or person authorized to manage the business of such juristic persons

## 1.1 Definitions

These definitions shall apply to the Enquiry, Bid for Supply, Lease, Hire or Work, or Hire of Consultant by Way of Selection.

1.1.1 **“Jointly Interested Bidder”** means a natural person or juristic person who submits bid to EGAT for the supply of goods, lease, hire of work, or hire of consultant by way of selection, as the case may be, and who has an interest, either directly or indirectly, in the business of another natural person or juristic person whose bid is also submitted to EGAT in this bidding.

The interest, either direct or indirect, in another natural person or juristic person as aforesaid includes the relationship in the following manners :

- (1) Management relationship, whereby the manager, the managing partner, the managing director, the executive or the person authorized to manage the business of a natural person or a juristic person has the power, or is able to exercise the power, in managing the business of the other one or more natural persons or juristic persons whose bids are also submitted to EGAT in this bidding.
- (2) Capital relationship, whereby a partner in an ordinary partnership or a partner with unlimited liability in a limited partnership or a major shareholder in a limited company or a public limited company is a partner in the other one or more ordinary partnerships or limited partnerships, or is a major shareholder in the other one or more limited companies or public limited companies whose bids are also submitted to EGAT in this bidding.
- (3) Cross relationship between (1) and (2), whereby the manager, managing partner, managing director, executive or person authorized to manage the business of a natural person or juristic person is a partner in the other one or more ordinary partnerships or limited partnerships, or is a major shareholder in the other one or more limited companies or public limited companies whose bids are also submitted to EGAT in this bidding, or *vice versa*.

**“Major shareholder”** means a shareholder who holds more than twenty five (25) percent of stake in such an enterprise or at another percentage determined by the Governor as he deems expedient for some types or sizes of enterprises.

Holding of position, being a partner or shareholding as aforesaid by the spouse or minor of the person in (1), (2) or (3) shall be deemed the holding of position, being a partner or shareholding by such person.

If any bidder uses the name of another person as the manager, managing partner, managing director, executive, partner or shareholder, but in which case he himself in fact exercises the power in management or he himself is the real partner or shareholder of the partnership or limited company or public limited company, as the case may be, and the related partnership or limited company or public limited company whose bid is also submitted to EGAT in this bidding, that bidder shall be deemed to have a relationship under (1), (2) or (3), as the case may be.

1.1.2 ***“Obstruction of Fair Price Competition”*** means any act committed by a bidder or bidders causing hindrance or obstruction or impeding the opportunity for fair price competition in the tendering of bid to EGAT, whether done by collusion, or by granting, requesting, or agreeing to grant, demand, accept or agreeing to accept money or property or other benefit or by committing an act of violence or by threatening to commit an act of violence or presenting a false document or doing any act in bad faith, with the objective of acquiring benefit among the other bidders or in order to give benefit to any specific bidder so that such person will be entitled to enter into a contract with EGAT or in order to avoid fair price competition, or in order to take advantage to EGAT which not being usual business practices.

DRAFT

1.2 Documentary List

This documentary list shall apply to the Enquiry, Bid for Supply, Lease, Hire of Work, or Hire of Consultant by Way of Selection.

		No. of page(s)	For EGAT only	
<b><u>Thai National Bidder</u></b>				
[ ]	1. Where the Bidder is a natural person or a group of persons other than a juristic person			
( )	(a) Natural Person		Yes	No
	- Certified copy of identity card .....		<input type="checkbox"/>	<input type="checkbox"/>
( )	(b) Group of persons			
	- Certified copy of partnership agreement or contract (if any) .....		<input type="checkbox"/>	<input type="checkbox"/>
	- Certified copy of identity card(s) of partners or related documents according to Item 2 (a) and (b) of each participant of the group .....		<input type="checkbox"/>	<input type="checkbox"/>
[ ]	2. Where the Bidder is a juristic person			
( )	(a) Ordinary partnership or limited partnership			
	- Certified copy of affidavit of incorporation .....		<input type="checkbox"/>	<input type="checkbox"/>
	- Name list of managing partners and list of persons entrusted with controlling power (if any) .....		<input type="checkbox"/>	<input type="checkbox"/>
	(Please fill in the form on page 10.)			
( )	(b) Limited company or public limited company			
	- Certified copy of affidavit of incorporation .....		<input type="checkbox"/>	<input type="checkbox"/>
	- Memorandum of Association .....		<input type="checkbox"/>	<input type="checkbox"/>
	- Name list of managing directors and list of persons entrusted with controlling power (if any) .....		<input type="checkbox"/>	<input type="checkbox"/>
	(Please fill in the form on page 10.)			
	- Name list of major shareholders .....		<input type="checkbox"/>	<input type="checkbox"/>
	(Please fill in the form on page 11.)			
[ ]	3. Other documents (if any)			
( )	Certified copy of any other registration required by Ministry of Commerce of Thailand .....		<input type="checkbox"/>	<input type="checkbox"/>
( )	Certified copy of registration for value added tax .....		<input type="checkbox"/>	<input type="checkbox"/>
( )	.....		<input type="checkbox"/>	<input type="checkbox"/>
( )	.....		<input type="checkbox"/>	<input type="checkbox"/>

No. of page(s)

For EGAT only

**Non-Thai National Bidder**

<p>[ ] 4. Where the Bidder is a natural person or a group of persons other than a juristic person</p> <p>( ) (a) Natural Person</p> <p style="padding-left: 20px;">- Certified copy of passport .....</p> <p>( ) (b) Group of persons</p> <p style="padding-left: 20px;">- Certified copy of partnership agreement or contract (if any) .....</p> <p style="padding-left: 20px;">- Certified copy of passport of partners or related documents according to Item 5 of each participant of the group .....</p> <p>[ ] 5. Where the Bidder is a juristic person</p> <p style="padding-left: 20px;">- Certified copy of affidavit of incorporation .....</p> <p style="padding-left: 20px;">- Name list of managing partners, directors, etc., as the case may be, and list of persons entrusted with controlling power (if any) .....</p> <p style="padding-left: 20px;">- Memorandum of Association (if any) (Please fill in the form on page 10.) .....</p> <p style="padding-left: 20px;">- Name list of major shareholders (if any) (Please fill in the form on page 11.) .....</p> <p>[ ] 6. Other documents (if any)</p> <p>( ) .....</p> <p>( ) .....</p> <p>( ) .....</p> <p>( ) .....</p> <p>( ) .....</p>	<table border="1" style="width: 100%; border-collapse: collapse;"> <thead> <tr> <th colspan="2"></th> <th style="text-align: center;">Yes</th> <th style="text-align: center;">No</th> </tr> </thead> <tbody> <tr> <td style="width: 20px;"></td> <td style="width: 20px;"></td> <td style="text-align: center;"><input type="checkbox"/></td> <td style="text-align: center;"><input type="checkbox"/></td> </tr> <tr> <td style="width: 20px;"></td> <td style="width: 20px;"></td> <td style="text-align: center;"><input type="checkbox"/></td> <td style="text-align: center;"><input type="checkbox"/></td> </tr> <tr> <td style="width: 20px;"></td> <td style="width: 20px;"></td> <td style="text-align: center;"><input type="checkbox"/></td> <td style="text-align: center;"><input type="checkbox"/></td> </tr> <tr> <td style="width: 20px;"></td> <td style="width: 20px;"></td> <td style="text-align: center;"><input type="checkbox"/></td> <td style="text-align: center;"><input type="checkbox"/></td> </tr> <tr> <td style="width: 20px;"></td> <td style="width: 20px;"></td> <td style="text-align: center;"><input type="checkbox"/></td> <td style="text-align: center;"><input type="checkbox"/></td> </tr> <tr> <td style="width: 20px;"></td> <td style="width: 20px;"></td> <td style="text-align: center;"><input type="checkbox"/></td> <td style="text-align: center;"><input type="checkbox"/></td> </tr> <tr> <td style="width: 20px;"></td> <td style="width: 20px;"></td> <td style="text-align: center;"><input type="checkbox"/></td> <td style="text-align: center;"><input type="checkbox"/></td> </tr> <tr> <td style="width: 20px;"></td> <td style="width: 20px;"></td> <td style="text-align: center;"><input type="checkbox"/></td> <td style="text-align: center;"><input type="checkbox"/></td> </tr> <tr> <td style="width: 20px;"></td> <td style="width: 20px;"></td> <td style="text-align: center;"><input type="checkbox"/></td> <td style="text-align: center;"><input type="checkbox"/></td> </tr> </tbody> </table>			Yes	No			<input type="checkbox"/>	<input type="checkbox"/>			<input type="checkbox"/>	<input type="checkbox"/>			<input type="checkbox"/>	<input type="checkbox"/>			<input type="checkbox"/>	<input type="checkbox"/>			<input type="checkbox"/>	<input type="checkbox"/>			<input type="checkbox"/>	<input type="checkbox"/>			<input type="checkbox"/>	<input type="checkbox"/>			<input type="checkbox"/>	<input type="checkbox"/>			<input type="checkbox"/>	<input type="checkbox"/>
		Yes	No																																						
		<input type="checkbox"/>	<input type="checkbox"/>																																						
		<input type="checkbox"/>	<input type="checkbox"/>																																						
		<input type="checkbox"/>	<input type="checkbox"/>																																						
		<input type="checkbox"/>	<input type="checkbox"/>																																						
		<input type="checkbox"/>	<input type="checkbox"/>																																						
		<input type="checkbox"/>	<input type="checkbox"/>																																						
		<input type="checkbox"/>	<input type="checkbox"/>																																						
		<input type="checkbox"/>	<input type="checkbox"/>																																						
		<input type="checkbox"/>	<input type="checkbox"/>																																						

**Thai and Non-Thai National Bidder**

		No. of page(s)	For EGAT only	
			Yes	No
[ ]	7. Where the Bidder is a joint venture / consortium			
	- Certified copy of association agreement	.....	<input type="checkbox"/>	<input type="checkbox"/>
( )	(a) If participant of a joint venture / consortium is not a juristic person			
	(i) Thai national			
	- Certified copy of identity card	.....	<input type="checkbox"/>	<input type="checkbox"/>
	(ii) Non-Thai national			
	- Certified copy of passport	.....	<input type="checkbox"/>	<input type="checkbox"/>
( )	(b) If participant of a joint venture / consortium is a Thai-national juristic person			
	( ) (i) Ordinary partnership or limited partnership			
	- Certified copy of affidavit of incorporation	.....	<input type="checkbox"/>	<input type="checkbox"/>
	- Name list of managing partners, and list of persons entrusted with controlling power (if any) (Please fill in the form on page 10.)	.....	<input type="checkbox"/>	<input type="checkbox"/>
	( ) (ii) Limited company or public limited company			
	- Certified copy of affidavit of incorporation	.....	<input type="checkbox"/>	<input type="checkbox"/>
	- Memorandum of Association	.....	<input type="checkbox"/>	<input type="checkbox"/>
	- Name list of managing directors, and list of persons entrusted with controlling power (if any) (Please fill in the form on page 10.)	.....	<input type="checkbox"/>	<input type="checkbox"/>
	- Name list of major shareholders (Please fill in the form on page 11.)	.....	<input type="checkbox"/>	<input type="checkbox"/>

		No. of page(s)	For EGAT only	
			Yes	No
( )	(c) If member of a joint venture / consortium is a Non-Thai national juristic person			
-	Certified copy of affidavit of incorporation	.....	<input type="checkbox"/>	<input type="checkbox"/>
-	Name list of managing partners, directors, etc., as the case may be, and list of persons entrusted with controlling power (if any) (Please fill in the form on page 10.)	.....	<input type="checkbox"/>	<input type="checkbox"/>
-	Memorandum of Association (if any)	.....	<input type="checkbox"/>	<input type="checkbox"/>
-	Name list of major shareholders (if any) (Please fill in the form on page 11.)	.....	<input type="checkbox"/>	<input type="checkbox"/>
[ ]	8. Other documents (if any)			
( )	Certified copy of any other registration required by Ministry of Commerce of Thailand	.....	<input type="checkbox"/>	<input type="checkbox"/>
( )	Certified copy of registration for value added tax in Thailand	.....	<input type="checkbox"/>	<input type="checkbox"/>
( )	.....	.....	<input type="checkbox"/>	<input type="checkbox"/>
( )	.....	.....	<input type="checkbox"/>	<input type="checkbox"/>
( )	.....	.....	<input type="checkbox"/>	<input type="checkbox"/>

We hereby confirm that all documents detailed above are true and correct.

Signed

\_\_\_\_\_  
(Name of Bidder)

stamp company seal (if any)

List of Names of Manager / Managing Partner / Managing Director / Executive /  
 Person Who Is Authorized to Manage the Business  
 (Relationship in Management)

Bidder shall fill in and submit this form with his bid

Enquiry / Bid No : ..... Enquiry / Bid Opening Date : .....

Name of Company / Partnership / Juristic Person : .....

No.	Name – Surname	Position	Name – Surname of Spouse	Name – Surname of Minor

We hereby confirm that all documents submitted are true and correct.

Signed \_\_\_\_\_  
 (Name of Bidder)

Stamp company seal (if any)

Remarks

1. The unused wordings shall be struck out.
2. Duplicate this page as necessary.

List of Partner in Ordinary Partnership / Partner with Unlimited Liability in Limited Partnership /  
Major Shareholder in Limited Company or Public Limited Company  
(Relationship in Capital)

Bidder shall fill in and submit this form with his bid

Enquiry / Bid No. : ..... Enquiry / Bid Opening Date : .....

Name of Company / Partnership / Juristic Person : .....

Registered Capital : (currency)..... Number of Share : ..... Price per Share : (currency).....

No.	Name - Surname	Position	Number of Share (%) or Amount of Shareholder's Equity	Name – Surname of Spouse	Number of Share (%) or Amount of Shareholder's Equity	Name – Surname of Minor	Number of Share (%) or Amount of Shareholder's Equity

We hereby confirm that all documents submitted are true and correct.

Signed \_\_\_\_\_

(Name of Bidder)

Stamp company seal (if any)

Remarks

1. The unused wordings shall be struck out.
2. "Major Shareholder" means a shareholder who holds more than twenty-five (25) per cent of stake in an enterprise. The shareholding of spouse or minor of a person shall be regarded as being the shareholding of such person. In case of no major shareholder, please specify "No major shareholder" in the tabulation above.
3. Duplicate this page as necessary.
4. The Bidder shall submit List of Names of Manager/ Managing Partner/ Managing Director/ Executive/ Person Who Is Authorized to Manage the Business (Relationship in Management)/ and List of Partner in Ordinary Partnership/ Partner with Unlimited Liability in Limited Partnership/ Major Shareholder in Limited Company or Public Limited Company (Relationship in Capital) of the Bidder as per page 10-11 of this Additional Regulation.

**Important Information**  
**for**  
**Invitation to Bid No. NPUP-MJ1-02 and LPLC-MJ1-01**

---

The purpose of this section is to inform the Bidders to **carefully study** the details of the revised terms and conditions in the bidding documents. The following provisions have been **recently revised** as stated hereunder:

**Article A-5. Preparation and Delivery of Bids and Article B-1. Preparation of Bids**

Details on how to prepare the proposal have been revised. Bids shall be prepared in accordance with the Instructions to Bidders contained in the Bidding Documents in one (1) original hard copy and one (1) electronic copy contained in USB flash drive.

**Article A-5. Preparation and Delivery of Bids**

Details of bid opening time and place shall be specified in the Tentative Schedule.

**Article A-6. Availability of Bidding Documents**

Availability of Bidding Documents has been changed from CD-ROM to electronic files for download via link provided by EGAT.

**Channel of Documents Submission**

For channel of document submission in the hereunder Articles, facsimile and telex has been replaced with letters submitted electronically or electronic mails (E-mails).

- Article B-1. Preparation of Bids
- Article B-4. Validity of Bids
- Article D-9. Notices
- Article E-17. Documents Required for Each Shipment
- Article F-8. Payment

## **Article B-2. Bid Prices**

For Source of Supply and Service b., Prices for Equipment manufactured outside Thailand (imported Equipment) shall be firm, stated both on FOB Port of Shipment/Vessel and CFR Thai Port basis, and quoted in Thai baht, US dollar, euro, Japanese yen, renminbi (Chinese yuan), or in the Bidder's or Manufacturer's home currency only if his currency trading is prevailed at the time of bidding in any international market other than in Bidder's or Manufacturer's home country.

The following paragraph has also been added :-

“Prices for the following Equipment manufactured outside Thailand which was imported before the bid opening date shall be firm ex-works and quoted in Thai baht, provided that the Bidder shall submit any document(s) evidencing the importation date of such Equipment:

- Power Fuse
- Stationary Battery and Battery Charger
- Insulator for substation
- Cable Termination
- Compression Connector and Miscellaneous Hardware
- Bus Fittings
- Grounding Material
- Substation Miscellaneous”

## **Article E-14. Preparation for Delivery**

The Instructions for Packaging attached at the end of Section E. General Conditions has been revised in item 8. Shunt Capacitor Bank.

## **Article E-16. Shipment**

The Maritime Promotion Bureau has been updated to the Maritime Promotion Division and its contact information has also been updated.

## **Article F-8. Payment**

After each payment is made, the Contractor or beneficiary shall issue and submit the receipt to EGAT as detailed in the paragraph added at the end of this article.

DRAFT

DATA SHEET

# DATA SHEET

for

## Invitation to Bid No. NPUP-MJ1-02 and LPLC-MJ1-01

---

This section consists of provisions that are specific to each procurement and supplement the information or requirements included in bidding documents.

### **Article B-3. Bid Security**

#### Schedule A1 and B2

The amount of bid security shall be USD 21,230.- or THB 685,000.-.

#### Schedule A2

The amount of bid security shall be USD 8,230.- or THB 265,500.-.

#### Schedule B1

The amount of bid security shall be USD 31,770.- or THB 1,025,000.-.

### **Article B-4. Validity of Bids**

The validity of the bid shall be for one hundred and fifty (150) Days from the date specified for opening of bid.

### **Article B-8. Information to be Submitted with Bid**

Item m. is not applicable

### **Article B-12. Evaluation and Comparison of Bids:**

The evaluation of bid prices shall be on:

- Combination of schedules A1 and B2
- Schedule basis for schedule A2
- Schedule basis for schedule B1

**Article E-29. Failure to Meet Requirements and F-10. Maintenance Guarantee**

Maintenance Guarantee Period

- For all Equipment except Shunt Reactor, 200 MVA 230 kV and above Power Transformer and 500 kV System Voltage Equipment

The Contractor shall guarantee the proper functioning of Equipment for a period of one (1) Year except the following Equipment the guarantee period of which shall be as follows :

<u>Equipment</u>	<u>Period of Guarantee (Year)</u>
- Fault Recording System	2
- Control and Protection System	2
- <u>For Shunt Reactor, 200 MVA 230 kV and above Power Transformer and 500 kV System Voltage Equipment</u>	

The Contractor shall guarantee the proper functioning of Equipment for a period of five (5) Years.

Defective Equipment to be replaced with the whole new set

None.

**Article F-9. Liquidated Damages for Late Delivery of Equipment**

The Liquidated Damages shall be at the rate of one-tenth of one (0.10) per cent of the price of each complete item of Equipment not timely delivered for each Day of delay. This sum is payable regardless of the actual loss and/or damages incurred.

**DRAFT**

**SECTION A  
INVITATION TO BID**

**INVITATION TO BID NO. NPUP-MJ1-02 and LPLC-MJ1-01**

**SUPPLY OF INSTRUMENT TRANSFORMER**

**TRANSMISSION SYSTEM DEVELOPMENT IN THE AREA OF NAN PHRAE AND  
UTTARADIT PROVINCES FOR POWER PURCHASE FROM LAO PDR PROJECTS**

**LONG-TERM INVESTMENT PLAN TO ACCOMMODATE LARGE POWER CONSUMER**

---

**A-1. Invitation**

The Electricity Generating Authority of Thailand (EGAT) hereby invites sealed bids for furnishing and delivering of Instrument Transformer under Transmission System Development in the Area of Nan Phrae and Uttaradit Provinces for Power Purchase from Lao PDR Projects and Long-Term Investment Plan to Accommodate Large Power Consumer hereinafter called Equipment in accordance with the terms, conditions and Specifications described in these Bidding Documents.

**A-2. Eligibility of Bidders: General Requirements**

All Bidders shall meet the following requirements; failure to so comply shall constitute sufficient ground for rejection.

- a. The Bidder shall be a partnership, firm or company, either alone or in joint venture or in consortium.
- b. The Bidder must have purchased the bidding documents from EGAT. For a joint venture or a consortium, only one (1) member of the joint venture or consortium is required to purchase the bidding documents.

In case the Bidder's name is not exactly the same as the purchaser's name, the purchaser shall notify EGAT of the name of the Bidder in writing prior to the bid opening time.

- c. The Bidder shall be well-established and maintain a permanent place of business. For a joint venture or consortium, all members of the joint venture or consortium are required to meet this qualification.
- d. The Bidder shall not be named in the List of Work Abandoners published by the Permanent Secretary, Ministry of Finance, and/or in the Debarment List and/or in the List of Work Abandoners declared by EGAT.

- e. For the Bidder who changes name before submitting the bid, his experience records in previous name shall be considered as the experience records of the Bidder.
- f. The Bidder shall not be a Jointly Interested Bidder with other Bidders as from the date of EGAT's issuance of this invitation to bid, or shall not be a person who undertakes any action as an "Obstruction of Fair Price Competition" as defined in Additional Regulation for this invitation.
- g. The Bidder shall not either be EGAT's consultant or involve in EGAT's consultancy company under this invitation, or have EGAT's personnel involved in his business as shareholder having voting right that can control his business, director, manager, officer, employee, agent or consultant except the ones who are officially ordered by EGAT to act or participate therein.
- h. The Bidder shall not be the person who is privileged or protected not to be taken any legal proceeding under Thai court; provided that such Bidder's government declares that such special privilege is waived.
- i. In case of a joint venture or consortium, the Bidder shall carry out all the provision of the Equipment and all Work under such formation from the time of bidding until the fulfillment of the Contract and the parties to the joint venture or the consortium shall accept joint and several liability for performing all obligations under the bid and the Contract.
- j. The Bidder shall not propose to supply the Equipment from the country under the state of war whether declared or not.
- k. The Bidder shall have adequate fund to meet financial obligations incidental to this Contract.
- l. The Bidder shall submit documentary evidence established in accordance with Article B-8. Information to be Submitted with Bid to demonstrate the Bidder's sufficient eligibility to bid and qualification to perform the Contract.

**A-3. Eligibility of Bidders: Technical Requirements**

**I. All Bidders shall meet the following requirements; failure to so comply shall constitute sufficient ground for rejection.**

- a. The Bidder shall manufacture or supply the Equipment or Work as required under this invitation to bid.
- b. If the Bidder is a new company formed by acquisition of or merger with other companies or business units before submitting the Bid, the experience records of

any of such previous companies or business units that meet the requirements set forth herein are acceptable as the experience records of the Bidder.

- c. The Bidder shall have no just or proper claims pending against the Bidder with respect to breach in the performance of contract on other similar works awarded by EGAT. If the Bidder is a new company formed by acquisition of or merger with other companies or business units, the pending claim of any of such previous companies or business units shall be considered pending claim of the Bidder.
- d. The Bidder shall have sufficient capacity to carry out the Work.
- e. The Bidder shall propose Equipment manufactured by the qualified manufacturers who shall fulfill the following requirements :
  - 1. Being well-established and maintaining a permanent place of business.
  - 2. The manufacturer shall have the experience records that meet the requirements set forth herein.

Reference records of either parent or affiliated companies shall not be considered as the records of such manufacturer.

- 3. If the Manufacturer is a new company formed by acquisition of or merger with other companies or business units, and any of such previous companies or business units has the experience records that meet the requirements set forth herein, such experience records are acceptable as the experience records of the new company, provided that each item of the equipment to be supplied under this bid shall be manufactured from the same source of supply as indicated in each of such relevant supply records as described in Item e.5 below. Otherwise, it shall not be acceptable and shall be sufficient grounds for rejection.

For the avoidance of doubt, it is not allowed to combine the experience records of the previous companies or business units in order to meet the experience requirements.

- 4. Regularly manufacturing of Equipment of the type and ratings proposed.
- 5. Having the qualifications for the required Equipment as follows:

Having one of the following qualifications:

- 5.1 Proposing the Equipment of the type and ratings which have ever been accepted by EGAT.

OR

- 5.2 Having a supply record of equipment of the type and ratings proposed with successful operation/use of at least five (5) consecutive years in an overseas country (not his own country) and at least fifteen (15) units. The ratings and features of equipment shall be the same or similar rating as EGAT specifies.

In case that the supply record of Equipment of the type and ratings proposed fulfilled the requirement, the manufacturer may propose a newly developed or modified type of such equipment with successful operation/use of at least one (1) year in overseas country (not his own country) and at least fifteen (15) units. The detailed information of the development or modification shall be submitted with his proposal. EGAT, however, reserves the right and will make its own judgment whether or not to consider or accept the proposed developed or modified type.

Supply records of the higher rating Equipment shall not be accepted if the Bidder does not propose such higher rating Equipment in his bid.

6. Having a past design test record of the Equipment as proposed, if specified in EGAT's specification. Such past design test record shall conform to the test specified in EGAT's specification.
7. Proposing the manufacturer who has no just or proper pending claims against Equipment on other similar works.

In case the manufacturer is a new company formed by acquisition or merger with other companies or business units, the pending claim of any of such previous companies or business units shall be considered pending claim of the manufacturer.

**II. All Bidders should preferably meet the following technical requirements; failure to so comply may constitute sufficient ground for rejection.**

- a. Proposing the steel supporting structure manufactured by local manufacturers.

**A-4. Joint Venture or Consortium**

In the event that the successful Bidder is a joint venture or a consortium formed of two or more companies, EGAT requires that the parties to the joint venture or the consortium accept joint and several liability for all obligations under the Contract.

**A-5. Preparation and Delivery of Bids**

Bids shall be prepared in accordance with the Instructions to Bidders contained in the Bidding Documents in one (1) original *hard copy and one (1) electronic copy contained in USB flash drive*, in English, on the bid forms included for this purpose and shall be accompanied with a bid security as required under Article B-3. Bid Security in a separate sealed envelope.

*For preparation of original hard copy, each page of the original hard copy shall be marked with the volume number and the page number in the lower right-hand corner, for example, Volume 1 of 10 and Page 1 of 100.*

*For preparation of electronic copy, each volume of the signed original hard copy shall be scanned into one (1) PDF file and each PDF file shall be named according to the volume number.*

*The USB flash drive shall contain electronic files of the proposal in the following formats :-*

- PDF files of all pages of each volume of the proposal, and*
- Excel files of filled-in Proposal Data, and*
- Excel files of filled-in Price Schedule*

*In the event of any discrepancy between the original hard copy and the electronic file(s), the original hard copy shall govern.*

The envelope of the bids will be marked in capital letters in the lower left-hand corner as follows :

**INVITATION TO BID NO. NPUP-MJ1-02 and LPLC-MJ1-01**

**SUPPLY OF INSTRUMENT TRANSFORMER**

**TRANSMISSION SYSTEM DEVELOPMENT IN THE AREA OF NAN PHRAE AND  
UTTARADIT PROVINCES FOR POWER PURCHASE FROM LAO PDR PROJECTS**

**LONG-TERM INVESTMENT PLAN TO ACCOMMODATE  
LARGE POWER CONSUMER**

and shall be addressed and delivered to *EGAT*, on or before 10:00 a.m., Bangkok Standard Time, .....*see Tentative Schedule*.....

If the envelope(s) is not sealed, marked and addressed as required above, EGAT will assume no responsibility for the bid misplacement or premature opening.

Bids will be opened publicly at the *place and* time specified in *Tentative Schedule*.

Bids received after the time stipulated herein shall be rejected and returned unopened.

**A-6. Availability of Bidding Documents**

The Bidding Documents are available for examination *and online purchase at* <http://www4.egat.co.th/fprocurement/biddingeng/> and can be obtained *by downloading via link provided by EGAT* upon payment to EGAT, non-refundable, in the amount of USD 10.- or Baht 300.-. These prices include the value added tax.

DRAFT

DRAFT

**SECTION B**  
**INSTRUCTIONS TO BIDDERS**

## INSTRUCTIONS TO BIDDERS

### Overview of the Procurement Process

Bid prices and the Contract Price shall include value added tax (VAT) imposed under the law of Thailand. The medium cost announced by EGAT is inclusive of VAT and other relevant expenses.

The amounts of performance security, maintenance security, and liquidated damages shall also be based on the Contract Price which is inclusive of VAT (if any).

For evaluation and comparison of Bids, the bid price shall be evaluated according to the conditions specified in the bidding document.

The procurement process is summarized in the following diagram.

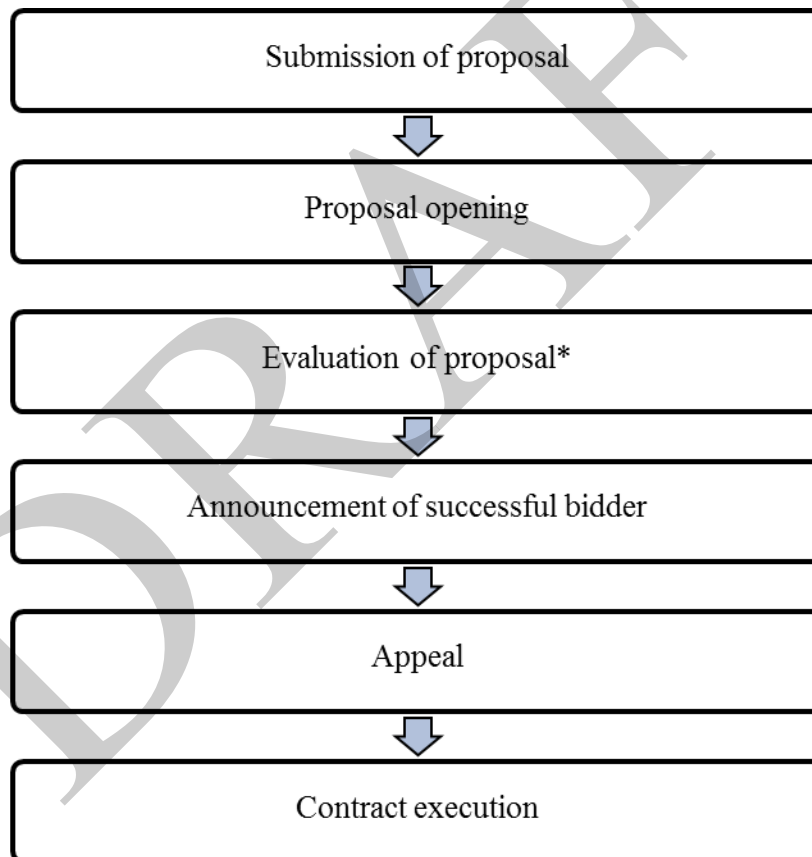

#### \*Remarks

1. The Bidder shall be deemed to have carefully examined all of the terms, conditions and Specifications of the Bidding Documents.
2. EGAT will take into consideration the conformity of the bid to the requirements of the Bidding Documents as well as the suitability for the purpose intended.
3. EGAT will not be bound to accept the bid with the lowest indicated cost. EGAT reserves the right to accept the bid which in its judgement is the lowest evaluated bid.

## **B-1. Preparation of Bids**

- a. Bids shall be prepared in English, in one (1) original *hard copy clearly marked “Original” and one (1) electronic copy contained in USB flash drive*, submitted at the place and time specified for receipt of bids.

In the event of any discrepancy between *the original hard copy and the electronic copy, the original hard copy* shall govern.

*For Proposal Data, Bidder shall fill in information of Proposal Data in Excel files contained in the Bidding Documents, and submit one (1) original hard copy with the PDF and Excel files in USB flash drive to EGAT at the same time of bid submission.*

For price quotation, Bidder *shall fill in* bid prices in an Excel files of Price Schedules contained in the Bidding Documents in accordance with Price Quotation Instructions in Section C, Part 1: Price Proposal, and submit one (1) original *hard copy with the PDF and Excel files in USB flash drive* to EGAT at the same time of bid submission.

VAT at the prevailing rate shall be filled automatically in the Summary of Bid Price of the price schedule in the Excel file subject to Article B-2. Bid Prices.

However, in case Bidder is a consortium formed of two or more companies, Bidder must also submit one (1) original hard copy *with the PDF and Excel files* of price schedules of the Work performed by each member of the consortium in addition to hard copies *with the PDF and Excel files* of the total bid price as specified above.

If any discrepancy between the bid prices of the Work performed by each member of the consortium and the bid prices of the Bidder occurs, the bid prices of the Bidder shall govern and the bid prices of the Work performed by each member of the consortium shall be adjusted accordingly.

In the event of discrepancy between the original hard copy *and the PDF or Excel files* submitted, the original hard copy shall govern.

- b. Bidder shall not submit more than two (2) proposals and the proposal(s) to be submitted shall conform to the specifications. In case of any deviation from the specifications, Bidder shall follow the provisions under Article B-9. Deviations from Specifications.
- c. The "Original" shall be prepared on the bid forms included and made a part of the Bidding Documents, which shall be submitted with all applicable blanks in the bid forms properly filled in, and shall be manually signed in ink by a person or

persons duly authorized. The letter of authorization shall be indicated by written power-of-attorney accompanying the bid.

All pages of the bid, except for unamended printed literature, shall be initialled by the person or persons signing the bid.

- d. The bid shall contain no interlineations, erasures or overwriting except as necessary to correct errors made by the Bidder, in which case such corrections shall be initialled by the person or persons signing the bid.
- e. Modification by letter or *by letter submitted electronically or by electronic mail (E-mail)* to bids already submitted will be considered if received prior to the time fixed for the receipt of bids. Confirmation by letter of any modification *evidenced* by post mark or by *letter submitted electronically or by electronic mail (E-mail)* should be sent to EGAT not later than the deadline for submission of Bids.
- f. No Bidder will be permitted to alter his bid after the bids have been opened, but clarifications not changing the substance of the bid therein may be accepted.
- g. Bidder may quote for any schedule or all schedules as called for, but shall quote for all items of the schedule(s) proposed. Consideration will be made as stipulated in Article B-12. Evaluation and Comparison of Bids.
- h. Any price discount to be offered shall be clearly stated in the Discount Form accompanied with the Bid to be submitted on the bid opening date specified herein.

## **B-2. Bid Prices**

### Currency

Bid prices as shown in Article C-1. Price Schedule shall be firm, not subject to adjustment and payable in the currencies as follows :

- a. The bid price shall be quoted in Thai baht, US dollar, euro, Japanese yen, renminbi (Chinese yuan), or in the Bidder's or Manufacturer's home currency only if his currency trading is prevailed at the time of bidding in any international market other than in Bidder's or Manufacturer's home country.

If the currencies quoted by the Bidder do not conform to the requirement set forth herein, EGAT reserves the right to convert the bid price to US dollars by using the exchange rate on the Bloomberg screen which is announced at 10.00 a.m. (Bangkok Time) on the bid opening date. Such converted bid price in US dollars shall be treated as the Bidder's proposed bid price. In such case the Contract Price for such portion under the Contract shall be made in US dollars.

Subject to paragraph a. above, in case the Bidder expects to incur a portion of its expenditures in the performance of the Contract in more than one currency and wishes to be paid accordingly, the bid price shall be expressed in different currencies and the respective amount in each currency together making up the total price.

- b. Local expenditures shall be quoted in Thai Baht.
- c. Payments will be made in the currency or currencies in which the bid prices have been stated.

#### Source of Supply and Service

- a. Prices for Equipment manufactured in Thailand shall be firm ex-works prices and quoted in Thai Baht. Any import duty and taxes (value added tax included) assessed by the Government of Thailand at the port of entry on imported raw materials or components shall be paid by the Contractor and included in these ex-works prices.
- b. Prices for Equipment manufactured outside Thailand (imported Equipment) shall be firm, stated both on FOB Port of Shipment/Vessel and CFR Thai Port basis, and quoted in currencies specified above. Any import duty, excise tax (if any) and value added tax to be assessed by the Government of Thailand at the port of entry shall not be included in the quoted bid prices.

***Prices for the following Equipment manufactured outside Thailand which was imported before the bid opening date shall be firm ex-works and quoted in Thai baht, provided that the Bidder shall submit any document(s) evidencing the importation date of such Equipment:***

- ***Power Fuse***
- ***Stationary Battery and Battery Charger***
- ***Insulator for substation***
- ***Cable Termination***
- ***Compression Connector and Miscellaneous Hardware***
- ***Bus Fittings***
- ***Grounding Material***
- ***Substation Miscellaneous***

- c. Prices for services including cost of installation supervisor (if any) shall be firm.
- d. All expenses incurred for the Work specified in Article F-1. Scope of Work shall be included in the quoted Bid Prices.

### Price Schedule

The Bidder shall enter a unit price, an amount, or a lump sum price, as required, for every item listed in the price schedule. If the unit price as entered does not conform to the amount entered for the same item, the unit price shall govern. If the sum of the amount entered for individual items does not conform to the total amount entered for these amounts under total bid prices, then the sum of the amount entered for the individual items shall govern.

Where quantity and total price only are required, the unit price shall be taken as the stated total price divided by the quantity specified.

Except for foreign supply, VAT at the prevailing rate shall be filled automatically in the Summary of Bid Price of the price schedule in the Excel file. However, the Contract Price shall include VAT only for the portion of Work which is subject to VAT.

### **B-3. Bid Security**

The original of the bid submitted shall be accompanied with a bid security in the form of a cash deposit, or a cashier cheque issued by a local bank, or a bank guarantee or a letter of guarantee issued only by a local bank or an acceptable financial institution in Thailand, or by a foreign bank counter-guaranteed by a local bank as primary obligor. In case of a cash deposit or a cashier cheque, only Thai baht can be made.

The bid security shall be in a form as per specimen attached or in any other form with essential content in accordance with the specimen, and made payable to EGAT in the amount as specified in Data Sheet. Any bid not being accompanied with bid security shall be rejected. The bid security shall remain in force up to and including ninety (90) Days after the expiry date of the bid validity.

The bid security shall be forfeited in favor of EGAT if :

- a. The Bidder withdraws his bid after the bid is opened; or
- b. The successful Bidder fails for any reason to execute the Contract or to furnish a performance security.

The Bidder may, upon EGAT's request to extend the bid security when it has expired, refuse to do so without forfeiting the bid security. A Bidder granting the request will be neither required nor permitted to modify his bids.

The bid security of unsuccessful Bidder(s) will be returned as decided by EGAT or within thirty (30) Days following EGAT's acceptance of the successful Bidder.

The bid security of the successful Bidder will be returned upon execution of the Contract and after the performance security furnished has been accepted by EGAT.

**B-4. Validity of Bids**

The validity of the bid shall be as specified in Data Sheet.

In the event EGAT requires the validity period to be extended, EGAT may in writing or by *letter submitted electronically or by electronic mail (E-mail)* so notify the Bidders at least fourteen (14) Days prior to the expiry date of the validity period, in which event any Bidder not agreeing to such request for extension may withdraw his bid by so advising EGAT in writing or by *letter submitted electronically or by electronic mail (E-mail)* prior to the expiry date of the original validity period. If the advice of withdrawal shall not have been received by EGAT prior to the said date, the extension shall be deemed to have been accepted by the Bidder, and the Bidder shall be required to extend the effective period of the bid security accordingly.

**B-5. Delivery of Bids**

Where bids are submitted by mail, the hour and date of receipt of the bid will be taken as that certified by EGAT. For all bids delivered directly, a receipt will be furnished to the Bidder indicating the place, hour, and date of delivery. Late bids will be returned unopened.

**B-6. Withdrawal of Bids**

Bids may be withdrawn only on written requests which are received by EGAT prior to the time fixed for the receipt of the bids. Negligence on the part of the Bidder in preparing his bid confers no right for the withdrawal of the bid after it has been opened. Whenever a bid has been withdrawn, it will be returned unopened to the Bidder.

**B-7. Interpretation of Bidding Documents before Bid Opening**

If a prospective Bidder is in doubt about the true meaning of any part of the Bidding Documents, the Bidder may submit to EGAT a written request for a reply or an interpretation; provided that sufficient time is allowed for a reply to reach the prospective Bidder prior to the date specified for bid opening. An interpretation will be given in the form of a Supplemental Notice furnished to all prospective Bidders. Receipt of all Supplemental Notices shall be acknowledged by each prospective Bidder on the Proposal. Oral interpretation of the Bidding Documents will not be binding.

**B-8. Information to be Submitted with Bid**

Each Bidder shall submit with his bid the following documents, data and information in English language in addition to any other information called for elsewhere in the Bidding Documents in order to enable EGAT to fully evaluate the Proposal of the Bidder :

- a. Name of manufacturer and country of origin and type or model of Equipment he proposes to furnish.
- b. Data, drawings, catalogue and descriptive materials which will show equipment arrangement, general dimensions, principles of operation, extent of factory assembly, and the materials from which parts are made.
- c. Sufficient references describing the technical experience of the manufacturers, including lists of the Equipment supplied and installed overseas. If possible, certificates issued by the user and/or consulting engineers supporting the said work and record of commercial operation in good condition should also be submitted.
- d. Copies of Auditor's certified balance sheet of the Bidder for the past three (3) consecutive years.
- e. In case the local manufactured Equipment is proposed, the sufficient documentary evidence, if any, showing that the manufacturers have been acknowledged for producing standard product by the Thai Industrial Standard Institute (TISI), Ministry of Industry, or registered with TISI, or ISO 9000 certified by the National Accreditation Council of Thailand (NAC) or obtained the privilege from the Board of Investment or accepted by EGAT for manufacture of such Equipment, is required to be submitted with the Bid.
- f. Sufficient evidence documents clearly demonstrating that a firm/company who changes its name, merges with, or acquires other company/companies, or forms a new company by merging its business unit with those of other companies, and the experience records of the new company clearly demonstrating that it has sufficient evidence of running the business as before.
- g. A statement of proposed minor deviations from the Specifications along with complete specifications and all necessary descriptive literature for any proposed alternative Equipment or procedure, as required under Article B-9. Deviations from Specifications.
- h. Where Proposal Data Forms are provided, the Bidder shall enter all information as directed.

- i. Where the Specifications provide for submission of a sample or samples, the Bidder shall submit same together with his bid.
- j. Joint Venture/Consortium Agreement with a statement that each member of a joint venture/consortium will be jointly and severally responsible and liable for the complete execution of the work (in case the Bidder is a joint venture or consortium).
- k. Confirmation Form of not being a Jointly Interested Bidder with other Bidders and not being a person who undertakes any actions as an Obstruction of Fair Price Competition, and Registration/Non-registration with the Revenue Department as a VAT registrant.

If the Bidder has registered as a VAT registrant, he shall submit EGAT an evidence of VAT registration. On the contrary, if the Bidder is not registered as a VAT registrant, he shall inform EGAT whether he will register as a VAT registrant or not.

In case the Bidder is a consortium, each member of the consortium shall fill in the Confirmation Form provided for consortium Bidders.

- l. Filled-in Documentary List and documents required according to Additional Regulation.
- m. A statement indicating that the parent manufacturer shall certify and be responsible for the design, production process and quality control. This information is required only for the Equipment specified in Data Sheet.

Should the Bidder fail to submit any of the document described above and neglect to submit the same to EGAT within the time as specified by EGAT, such failure shall be sufficient reason for rejection of his bid.

Verbal statements made by the Bidder at any time regarding quality, quantity, or arrangement of Equipment will not be considered.

If alternative Equipment is indicated in the bid, it shall be understood that EGAT will have the option of selecting any one of the alternates so indicated and such selection shall not be a cause for extra compensation or extension of time.

In case the Bidder proposes alternative Equipment, with the condition to supply any one of the alternates so indicated at his option, such bid will be considered conditional and may be considered sufficient reasons for rejection.

**B-9. Deviations from Specifications**

Unless otherwise provided in the Specifications, the quality of Equipment and workmanship shall comply in all respects with the Standards required under the bidding documents.

If the Bidder proposes any minor deviations from the specifications, he shall submit a statement of each proposed deviation referenced to the particular Article of these specifications, details on the design drawings or article, paragraph and section of referenced standards or specifications. Full details of all minor deviations together with confirmation shall be submitted with the bid in a form provided in Section C. The Bidder shall submit, with his bid, copies of the standards or specifications proposed for his deviations. In case there is no statement in the form provided in Section C in the Bidder's proposal on the proposed deviations, the bid shall be regarded by EGAT as conforming in all respects to the terms and conditions and Specifications as stated in the bidding documents at no additional cost to the bid price.

Notwithstanding the foregoing, it is at EGAT's sole discretion in determining whether any of such proposed deviations is acceptable and in determining whether it is minor or major deviation.

**B-10. Rejection of Bids**

EGAT reserves the right not to accept the lowest evaluated bid.

Bids shall be strictly based on the Specifications and terms and conditions in the Bidding Documents. Should any bid fail to comply with the terms and conditions stipulated in these Bidding Documents, especially those under Article pertaining to payment or be incomplete, conditional or obscure, or contain additions not called for, or irregularities of any kind, it will be liable to rejection.

EGAT also reserves the right to reject any or all bids submitted without giving reason or to reject the bid from any Bidder who fails to satisfy EGAT that the bid complies with the terms and conditions stipulated in these bidding documents without any non-compliance which is deemed substantial and advantageous over other Bidders.

**B-11. Delivery Time**

Delivery time required is indicated for each respective Price Schedule in the Proposal section of the Bidding Documents, and shall be carefully observed. However, no preference will be given in the bid evaluation for earlier delivery than the stipulated delivery period.

All bids specifying delivery time later than those indicated may be rejected.

## **B-12. Evaluation and Comparison of Bids**

Bid prices pursuant to Article B-2. Bid Prices will be evaluated as follows :

1. The evaluation of bid prices shall be specified in Data Sheet.
2. Bid prices will be converted into Thai Baht at the selling exchange rates, published by the Bank of Thailand, [www.bot.or.th](http://www.bot.or.th) between Baht and other currencies on the bid opening date.
3. The rate of import duty prevailed on the bid opening date will be used for the purpose of bid evaluation of CFR Thai Port Price.
4. The prices to be used for evaluation and comparison purpose shall be as follows :
  1. Ex-works price including VAT for the final sale direct to EGAT for locally manufactured Equipment
  2. CFR Thai Port of Equipment to be imported plus the calculated insurance premium of 0.072% of [CFR price+10% (CFR price)], import duty, excise tax (if any), value added tax to be assessed by the Thai Government at the port of entry for imported Equipment , and 0.6 % of CFR price for customs clearance

The rate of import duty to be used for price comparison shall be as follows:

- a) For Equipment consisting of separate components which are intended to contribute together as a functional unit and imported under partial import entry - using a normal single tariff rate published in the Customs Tariff Decree for such Equipment
- b) For other Equipment and spare parts
  - i) In case any imported Equipment and spare part is proposed from one (1) country of origin for the same item:
    - Country of Origin Under Free Trade Agreement (FTA) – using lower comparing rate between the FTA rate and the normal rate published in the Customs Tariff Decree;
    - Country of Origin Under Non FTA – using a normal rate published in the Customs Tariff Decree.
  - ii) In case any imported Equipment and spare part is proposed from different countries of origin for the same item, a normal rate published in the Customs Tariff Decree for such Equipment and spare part will be used for price comparison.

3. Cost of local transportation including VAT, if any
4. Cost of installation supervisor including VAT, if any
5. Guaranteed losses of Equipment, if any, at the rate as stipulated in the Proposal Data.

Price for optional items, if any, will not be taken into consideration; however, Bidders shall also quote the prices thereof as required.

**B-13. Acceptance of Bids**

EGAT will not be bound to accept the bid with the lowest indicated cost. EGAT reserves the right to accept the bid which in its judgement is the lowest evaluated bid. In making its selection, EGAT will take into consideration the conformity of the bid to the requirements of the Bidding Documents and Specifications, guaranteed delivery time, the suitability for the purpose intended and whenever applicable, compensating factors will be applied to deviation or departures from Specifications. EGAT will also take into consideration whether the Bidder's experience, organization, facilities and financial resources will assure the successful carrying out of the Work under the Contract within the time specified.

**B-14. Appeal**

Disqualified or unsuccessful Bidders who see that their disqualification or failure are due to EGAT's non-compliance with EGAT's procurement regulations may appeal to EGAT within fifteen (15) Days from the date of receipt or announcement, whichever comes first, of EGAT's final evaluation result. An appeal shall be made in writing and clearly state the cause of appeal and argument with referred facts or regulations and related documents. Appealing does not constitute a ground for suspending the ongoing procurement process unless EGAT's Governor agrees otherwise.

The Contract or Purchase Order shall not be executed until the period of appeal has ended and there is no appeal. In the event there is an appeal during such period, the Contract or Purchase Order shall not be executed unless EGAT's Governor concurs.

Decision of EGAT's Governor is final and conclusive.

**B-15. Award of Contract**

The Contract will be awarded as soon as practicable after opening of the bids, to the Bidder with the lowest evaluated bid. EGAT reserves the right to award the Contract on the basis of standards and specifications as proposed by the Bidder, if in the opinion of EGAT, they are considered acceptable.

At the time of execution of the Contract, the successful Bidder shall furnish the performance security in accordance with the conditions of Contract in the specimen of performance security provided in the bidding documents.

Failure to comply with the condition as expressed in the specimen of performance security will lead to withdrawal of award and cancellation of Contract, and in this respect EGAT reserves the right to award the Contract to the Bidder with the next lowest evaluated substantially responsive bid and the Bidder who defaults shall have his bid security forfeited in favor of EGAT.

After EGAT notifies the successful Bidder that his bid has been accepted, EGAT will send the Bidder the Contract Documents incorporating all agreements between the parties not later than ninety (90) Days after confirmation of Letter of Award of Contract.

Promptly but not later than fifteen (15) Days after receipt of the Contract, the successful Bidder shall sign and date the Contract and return it to EGAT.

**B-16. Bidder's Responsibility**

The Bidder shall be deemed to have carefully examined all of the terms, conditions and Specifications of this Invitation to Bid, and also to have fully informed himself as to all conditions, local or otherwise, affecting the carrying out of the Work of the Contract, and to have formulated an estimate of the facilities available and needed.

The Bidder shall also be liable to any rules and regulations as well as Acts enforced in the Kingdom of Thailand. Failure to do so will be at the Bidder's risk.

**B-17. Supplemental Notices**

Supplemental Notices to the Bidding Documents may be issued prior to the date of opening of bids to clarify the Bidding Documents or to reflect modifications in the design or Contract terms. Each supplemental notice issued will be distributed to each person or organization to whom the Bidding Documents have been issued. The recipient shall acknowledge receipt of each supplemental notice by signing and returning in a reasonable time the receipt form distributed with the supplemental notice. All supplemental notices issued shall become a part of the Contract Documents.

**B-18. Cost of Bidding**

Bidders will not be reimbursed for any expenses they may incur in preparing and submitting their bids.

**B-19. Cancellation of Bid**

EGAT reserves the right not to accept any quantity or item or schedule or package, or to cancel the bid without purchasing any item. Bidders shall not be entitled to claim EGAT for any losses and/or damages in this connection. EGAT also reserves the right to cancel the bid should there be any reasonable grounds that bidder is not in good faith in submitting bid such as submitting false documents.

In case of bid cancellation, EGAT will not be responsible for any losses and/or damages and will not refund payment of Bidding Documents.

DRAFT

***SPECIMEN OF BID SECURITY***

Whereas.....(hereinafter called "the Bidder") has submitted his bid dated.....for.....(hereinafter called "the Bid") under Invitation to Bid No.....KNOW ALL MEN by these presents that WE.....of.....having our registered office at.....(hereinafter called "the Guarantor") are bound unto Electricity Generating Authority of Thailand (hereinafter called "EGAT") in the sum of..... (in words : ..... ) for which payment well and truly to be made to EGAT, the Guarantor binds itself, its successors and assigns by these presents. Sealed with the Common Seal of the said Bank this.....(date).....day of.....(month)....., .....(year).....

THE CONDITIONS of this obligation are :

1. If the Bidder withdraws his bid during the period of bid validity specified in the Bidding Documents; or
2. If the Bidder, having been notified of the acceptance of his bid by EGAT during the period of bid validity;
  - (a) fails or refuses to execute the Contract, if required; or
  - (b) fails or refuses to furnish the Performance Security, in accordance with the Instructions to Bidders;

We, the Guarantor, unconditionally undertake to pay to EGAT as the primary obligor, up to the above amount upon receipt of its first written demand, without EGAT having to substantiate its demand.

This guarantee will remain in force up to and including ninety (90) Days after the expiry date of the bid validity.

\_\_\_\_\_  
(Signature of the Bank)

**DRAFT**

**SECTION C  
PROPOSAL**

INVITATION TO BID NO. NPUP-MJ1-02 and LPLC-MJ1-01

PROPOSAL

FOR

SUPPLY OF INSTRUMENT TRANSFORMER

TRANSMISSION SYSTEM DEVELOPMENT IN THE AREA OF NAN PHRAE AND  
UTTARADIT PROVINCES FOR POWER PURCHASE FROM LAO PDR PROJECTS

LONG-TERM INVESTMENT PLAN TO ACCOMMODATE LARGE POWER CONSUMER

---

**C-1. Price Schedule**

The undersigned Bidder, having carefully examined the Bidding Documents, hereby offers and proposes to perform the services and to furnish the Equipment on the basis of FOB Port of Shipment/Vessel or CFR Thai Port as specified in the Delivery Schedule and Distribution List for foreign supply or Ex-works delivery for local supply, in accordance with all provisions and conditions as described herein, all for the prices stated in the Schedule(s) attached.

Note : 1. Article C-1. Price Schedule

For imported Equipment, EGAT reserves the right to award the Contract on either FOB Port of Shipment/Vessel or CFR Thai Port basis.

2. Article E-12. Performance Security

The performance security required under Article E-12. Performance Security shall be ten (10) per cent, round up to the nearest whole number, of the Contract Price. Cost for furnishing the performance security shall be spread over the items proposed.

**C-2. Penalty for Equipment Not Meeting Guaranteed Characteristics**

The losses of Equipment shall be evaluated with the same rate as stipulated in the Proposal Data.

If the Equipment proposed fails to meet the guaranteed characteristics or the price of the measured losses is higher than the price of the guaranteed losses, the Contract price of Equipment shall be reduced by the different amount of the comparison between the price of the measured losses and the price of the guaranteed losses.

**C-3. Guaranteed Delivery Time**

Delivery Time of Equipment is required as indicated in the Delivery Schedule and Distribution List attached. The undersigned Bidder guarantees to make and to complete the delivery of Equipment proposed as required by EGAT.

Whenever the Equipment in any item are sub-itemized, the Contractor shall endeavor not to make partial shipment/delivery by sub-items.

In case of failure on the part of the Contractor to comply with the provision of the above paragraph, it is hereby understood that the Equipment in such particular items shall be deemed undelivered unless and until each all sub-items have been shipped/delivered.

**C-4. Drawing and Document Submission Schedule**

Drawing and Document Submission Schedule is required as indicated in Article F-11. Drawings and Documents to be Furnished by Contractor. The undersigned Bidder guarantees to submit all drawings and documents as required by EGAT.

**C-5. Estimate of Deliveries**

The estimated number of individual shipment/delivery, shipping point or points, estimated delivery date and estimated shipping weights and volumes for each individual shipping will be as follows :

<u>Number of Shipments</u>	<u>Item No.</u>	<u>Shipping Point</u>	<u>Estimated Delivery Date from Shipping Point</u>	<u>Total Weight kg.</u>	<u>Total Volume Cu.m.</u>
-----	-----	-----	-----	-----	-----
-----	-----	-----	-----	-----	-----
-----	-----	-----	-----	-----	-----
-----	-----	-----	-----	-----	-----

**C-6. Bid Security**

Bid security in the amount of \_\_\_\_\_,  
(in words)  
\_\_\_\_\_ has been deposited with EGAT.  
(number)

**C-7. Supplemental Notices**

The undersigned Bidder certifies that the following Supplemental Notices have been received for the Contract Documents :

\_\_\_\_\_  
\_\_\_\_\_  
\_\_\_\_\_  
\_\_\_\_\_  
\_\_\_\_\_

Proposal Submission Date \_\_\_\_\_ Day of \_\_\_\_\_ A.D. \_\_\_\_\_

Firm's Name \_\_\_\_\_

By \_\_\_\_\_

Title \_\_\_\_\_

Firm's Address \_\_\_\_\_

\_\_\_\_\_

\_\_\_\_\_

Witness

\_\_\_\_\_

DRAFT

**PART 1: PRICE PROPOSAL**

**PART 1 : PRICE PROPOSAL**  
**PRICE QUOTATION INSTRUCTIONS**

This part of the Bidding Document comprises :

1. Summary of Bid Prices
2. Price Schedules

Cost of Supply of Equipment comprises Foreign Portion and Local Portion. For Foreign Portion, Bidder is allowed to quote price in only four (4) different currencies. For Local Portion, default currency is Baht (THB).

Bidder shall fill in the price schedules in the Excel file(s), item by item. Then, the total prices for each schedule and Summary of Bid Prices will be automatically calculated.

Filling-in the data shall be in accordance with the following instructions :

1. Bidder shall fill in all data required in blue cells of the price schedules - Currency and Unit Price.
2. For local portion, the default is THB.
3. For foreign portion, Bidder shall fill a currency code in a column "Currency".

Remarks: Price Schedules are created in Microsoft Office Excel 2007.

INVITATION TO BID NO. NPUP-MJ1-02 and LPLC-MJ1-01

SUMMARY OF BID PRICE

SUPPLY OF INSTRUMENT TRANSFORMER

TRANSMISSION SYSTEM DEVELOPMENT IN THE AREA OF NAN PHRAE AND UTTARADIT PROVINCES FOR POWER PURCHASE FROM LAO PDR PROJECTS  
LONG-TERM INVESTMENT PLAN TO ACCOMMODATE LARGE POWER CONSUMER

No.	Description	Currency	Supply of Equipment	
			Foreign Supply	Local Supply
			CFR Thai Port	Ex-works Price (excluding VAT) Baht
			Amount	Amount
1	Schedule A1 : 500 kV Coupling Capacitor Voltage Transformer			
2	Schedule B2 : 500 kV Coupling Capacitor Voltage Transformer			
<b>BID PRICE</b>				<b>Baht</b>
<b>VAT</b>				<b>Baht</b>
<b>SUMMARY OF BID PRICE</b>				<b>Baht</b>

**INVITATION TO BID NO. NPUP-MJ1-02 and LPLC-MJ1-01**

**SUMMARY OF BID PRICE**

**SUPPLY OF INSTRUMENT TRANSFORMER**

**TRANSMISSION SYSTEM DEVELOPMENT IN THE AREA OF NAN PHRAE AND UTTARADIT PROVINCES FOR POWER PURCHASE FROM LAO PDR PROJECTS  
LONG-TERM INVESTMENT PLAN TO ACCOMMODATE LARGE POWER CONSUMER**

No.	Description	Currency	Supply of Equipment	
			Foreign Supply	Local Supply
			CFR Thai Port	Ex-works Price ( excluding VAT ) Baht
			Amount	Amount
1	Schedule A2 : 500 kV Inductive Voltage Transformer			
	<b>BID PRICE</b>			<b>Baht</b>
	<b>VAT</b>			<b>Baht</b>
	<b>SUMMARY OF BID PRICE</b>			<b>Baht</b>

**INVITATION TO BID NO. NPUP-MJ1-02 and LPLC-MJ1-01**

**SUMMARY OF BID PRICE**

**SUPPLY OF INSTRUMENT TRANSFORMER**

**TRANSMISSION SYSTEM DEVELOPMENT IN THE AREA OF NAN PHRAE AND UTTARADIT PROVINCES FOR POWER PURCHASE FROM LAO PDR PROJECTS  
LONG-TERM INVESTMENT PLAN TO ACCOMMODATE LARGE POWER CONSUMER**

No.	Description	Currency	Supply of Equipment	
			Foreign Supply	Local Supply
			CFR Thai Port	Ex-works Price ( excluding VAT ) Baht
			Amount	Amount
1	Schedule B1 : 500 kV Current Transformer			
	<b>BID PRICE</b>			<b>Baht</b>
	<b>VAT</b>			<b>Baht</b>
	<b>SUMMARY OF BID PRICE</b>			<b>Baht</b>

**INVITATION TO BID NO. NPUP-MJ1-02 and LPLC-MJ1-01**  
**Schedule A1 : 500 kV Coupling Capacitor Voltage Transformer**  
**SUPPLY OF INSTRUMENT TRANSFORMER**

**TRANSMISSION SYSTEM DEVELOPMENT IN THE AREA OF NAN PHRAE AND UTTARADIT PROVINCES FOR POWER PURCHASE FROM LAO PDR PROJECTS**

Item No.	Description	Qty.	Unit	Currency	Supply of Equipment				Supply of Equipment	
					Foreign Supply				Local Supply	
					FOB Vessel	Cost of Transportation to Thai Port	CFR Thai Port		Ex-works Price (excluding VAT) Baht	
					Unit Price	Unit Price	Unit Price	Amount	Unit Price	Amount
A1-1	525 kV CCVT, 525000/√3 : 120/(120/√3) & 120/(120/√3) & 120/(120/√3) V, with carrier accessories, oil filled as per ratings and features RF PD9W1A	6								
A1-2	525 kV CCVT, 525000/√3 : 120/(120/√3) & 120/(120/√3) & 120/(120/√3) & 120/(120/√3) V, with carrier accessories, oil filled as per ratings and features RF PD9W1B	6								
A1-3	Steel Supporting Structure for PD9W1A (for item no.A1-1), H = 9.00 m. as per Dwg. No. ST-VT-9-01 and SD-AB-0-01	6			XXXXXX	XXXXXX	XXXXXX	XXXXXX		
A1-4	Steel Supporting Structure for PD9W1B (for item no.A1-2), H = 9.00 m. as per Dwg. No. ST-VT-9-01 and SD-AB-0-01	6			XXXXXX	XXXXXX	XXXXXX	XXXXXX		
	Equipment which shall be used together as a complete set referring to Article relevant to Liquidated Damages for Late Delivery of Equipment are item nos. A1-1 with A1-3 and A1-2 with A1-4									
<b>Total Price for Schedule A1</b>									<b>Baht</b>	

**INVITATION TO BID NO. NPUP-MJ1-02 and LPLC-MJ1-01**

**Schedule A2 : 500 kV Inductive Voltage Transformer**

**SUPPLY OF INSTRUMENT TRANSFORMER**

**TRANSMISSION SYSTEM DEVELOPMENT IN THE AREA OF NAN PHRAE AND UTTARADIT PROVINCES FOR POWER PURCHASE FROM LAO PDR PROJECTS**

Item No.	Description	Qty.	Unit	Currency	Supply of Equipment				Supply of Equipment	
					Foreign Supply				Local Supply	
					FOB Vessel	Cost of Transportation to Thai Port	CFR Thai Port		Ex-works Price (excluding VAT) Baht	
					Unit Price	Unit Price	Unit Price	Amount	Unit Price	Amount
A2-1	525 kV VT, 525000/√3 : 120/(120/√3) & 120/(120/√3) & 110 V, oil filled as per ratings and features RF VT901A	6								
A2-2	Steel Supporting Structure for VT901A (for item no.A2-1), H = 9.00 m. as per Dwg. No. ST-VT-9-01 and SD-AB-0-01	6			XXXXXX	XXXXXX	XXXXXX	XXXXXX		
	Equipment which shall be used together as a complete set referring to Article relevant to Liquidated Damages for Late Delivery of Equipment are item nos. A2-1 with A2-2									
<b>Total Price for Schedule A2</b>									<b>Baht</b>	

**INVITATION TO BID NO. NPUP-MJ1-02 and LPLC-MJ1-01**

**Schedule B1 : 500 kV Current Transformer**

**SUPPLY OF INSTRUMENT TRANSFORMER**

**LONG-TERM INVESTMENT PLAN TO ACCOMMODATE LARGE POWER CONSUMER**

Item No.	Description	Qty.	Unit	Currency	Supply of Equipment				Supply of Equipment	
					Foreign Supply				Local Supply	
					FOB Vessel	Cost of Transportation to Thai Port	CFR Thai Port		Ex-works Price (excluding VAT) Baht	
					Unit Price	Unit Price	Unit Price	Amount	Unit Price	Amount
B1-1	550 kV CT, 2000-3000-4000/1A (6 cores), 50 kA, oil filled as per Rating and Features RF CT9AFAI	6								
B1-2	550 kV CT, 2000-3000-4000/1A (6 cores), 50 kA, oil filled as per Rating and Features RF CT9AFDI	6								
B1-3	Steel Supporting Structure for CT9AFAI (for item no.B1-1), H = 9.00 m. as per Dwg. No. ST-CT-9-01 and SD-AB-0-01	6			XXXXXX	XXXXXX	XXXXXX	XXXXXX		
B1-4	Steel Supporting Structure for CT9AFDI (for item no.B1-2), H = 9.00 m. as per Dwg. No. ST-CT-9-01 and SD-AB-0-01	6			XXXXXX	XXXXXX	XXXXXX	XXXXXX		
	Equipment which shall be used together as a complete set referring to Article relevant to Liquidated Damages for Late Delivery of Equipment are item nos. B1-1 with B1-3 and B1-2 with B1-4									
<b>Total Price for Schedule B1</b>										<b>Baht</b>

**INVITATION TO BID NO. NPUP-MJ1-02 and LPLC-MJ1-01  
Schedule B2 : 500 kV Coupling Capacitor Voltage Transformer**

**SUPPLY OF INSTRUMENT TRANSFORMER**

**LONG-TERM INVESTMENT PLAN TO ACCOMMODATE LARGE POWER CONSUMER**

Item No.	Description	Qty.	Unit	Currency	Supply of Equipment				Supply of Equipment	
					Foreign Supply				Local Supply	
					FOB Vessel	Cost of Transportation to Thai Port	CFR Thai Port		Ex-works Price (excluding VAT) Baht	
					Unit Price	Unit Price	Unit Price	Amount	Unit Price	Amount
B2-1	525 kV CCVT, 525000/√3 : 120/(120/√3) & 120/(120/√3) & 120/(120/√3) V, with carrier accessories, oil filled as per ratings and features RF PD9W1A	7								
B2-2	Steel Supporting Structure for PD9W1A (for item no.B2-1), H = 9.00 m. as per Dwg. No. ST-VT-9-01 and SD-AB-0-01	7			XXXXX	XXXXX	XXXXX	XXXXX		
	Equipment which shall be used together as a complete set referring to Article relevant to Liquidated Damages for Late Delivery of Equipment are item nos. B2-1 with B2-2									
<b>Total Price for Schedule B2</b>									<b>Baht</b>	

DRAFT

**PART 2: PROPOSAL DATA**



**COUPLING CAPACITOR VOLTAGE TRANSFORMER**

FORM PD 761  
Jan. 2026

**PROPOSAL DATA**

**PROCUREMENT REFERENCE**

**SCHEDULE NO.**

**BIDDER**

**ITEM NO.**

- a. Manufacturer / Country - For CCVT  
- For Supporting Structure
- b. Type / Model / Catalog No.
- c. Applied Standards
- d. Rated Primary Voltage / Frequency  kV  Hz
- e. Highest Voltage for Equipment  kV
- f. Rated Insulation Level - Power Freq. Withstand (Dry / Wet)  
- Lightning / Switching Impulse Withstand Voltage  kV  kV  
 kV  kV
- g. Insulator - Creepage Distance / Color  
- Cement Flange Type  mm   
 Yes  No
- h. Transformation Ratio
- i. Rated Secondary Voltage
  - No.1 Secondary Winding  V
  - No.2 Secondary Winding  V
  - No.3 Secondary Winding  V
  - No.4 Secondary Winding  V
- j. Rated Output
  - No.1 Secondary Winding  VA
  - No.2 Secondary Winding  VA
  - No.3 Secondary Winding  VA
  - No.4 Secondary Winding  VA
  - Simultaneous / Thermal  VA  VA
- k. Rated Accuracy Class
  - No.1 Secondary Winding
  - No.2 Secondary Winding
  - No.3 Secondary Winding
  - No.4 Secondary Winding
- l. Capacitance - C1 / C2  
- Rated  pF  pF  
 pF
- m. Primary Voltage Rating of Intermediate Transformer  kV
- n. Potential Grounding Switch  With
- o. Available Short Circuit Current at Each Secondary Tapping
  - No.1 Secondary Winding  A  A
  - No.2 Secondary Winding  A  A
  - No.3 Secondary Winding  A  A
  - No.4 Secondary Winding  A  A
- p. Oil Expansion System
  - Type  Bellow  N<sub>2</sub> Cushion
  - Material of Bellow  Other   
 Metallic  Rubber  
 Other

**Remark**

**COUPLING CAPACITOR VOLTAGE TRANSFORMER**

FORM PD 761  
Jan. 2026

**PROPOSAL DATA**

**PROCUREMENT REFERENCE**

**SCHEDULE NO.**

**BIDDER**

**ITEM NO.**

q. Ferroresonance Suppression Device

Resistive and/or Reactive Element

r. Carrier Drain Coil

- Impulse Withstand Voltage
- Frequency Range
- Insertion Loss at Specified Freq. Range
- Voltage Drop at 50 Hz
- Inductance of Carrier Drain Coil
- Impedance at Specified Freq. Range
- Impedance at 50 Hz
- Continuous/Short Time Current/Duration
- Protective Gap Setting

<input type="text"/>	kV
<input type="text"/>	kHz
<input type="text"/>	dB
<input type="text"/>	V
<input type="text"/>	mH
<input type="text"/>	Kilo-Ohms
<input type="text"/>	Ohms
<input type="text" value="A/"/> <input type="text"/> <input type="text" value="A/"/>	s
<input type="text" value="mm"/> <input type="text"/>	kV
<input type="text"/>	kg
<input type="text"/>	Litres

s. Total Weight

t. Volume of Oil

Remark

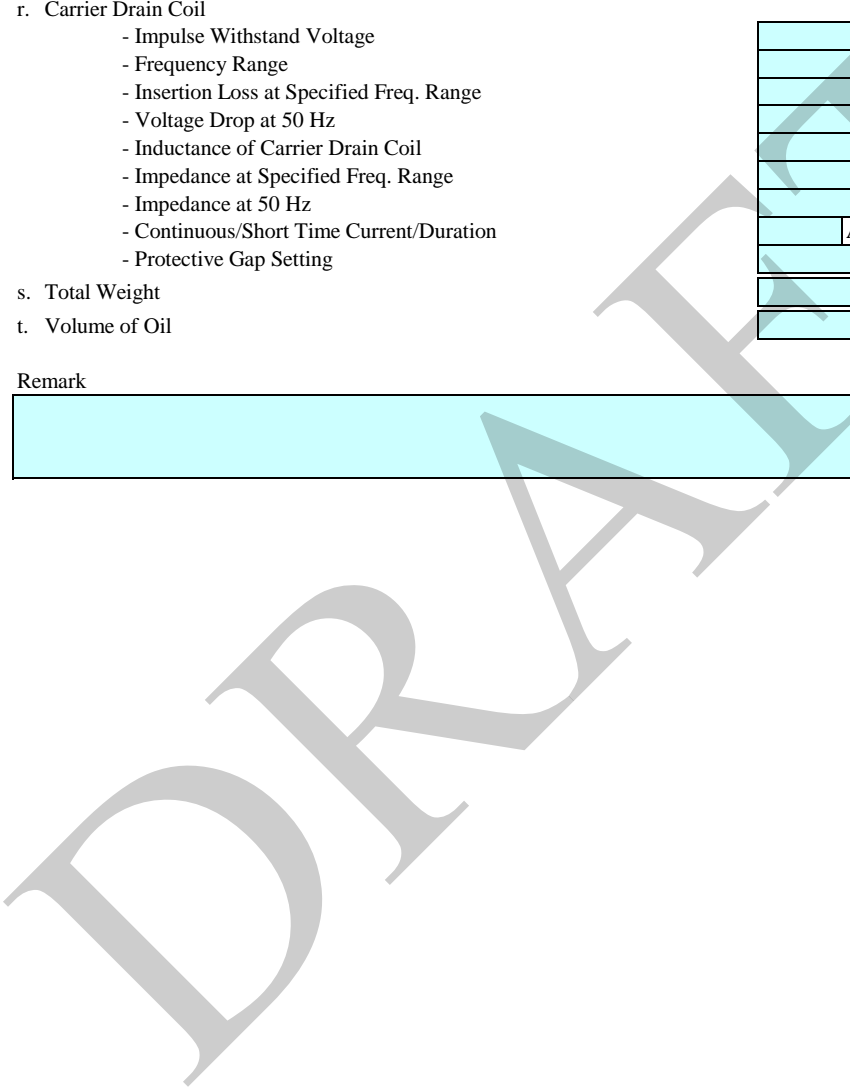

**INDUCTIVE VOLTAGE TRANSFORMER**

FORM PD 762  
Jan. 2026

**PROPOSAL DATA**

**PROCUREMENT REFERENCE** NPUP-MJ1-02 and LPLC-MJ1-01

**SCHEDULE NO.**  

**BIDDER**  

**ITEM NO.**  

- a. Manufacturer / Country
  - For VT
  - For Supporting Structure
- b. Type / Model / Catalog No.
- c. Applied Standards
- d. Rated Primary Voltage / Frequency   kV/   Hz
- e. Highest Voltage for Equipment   kV
- f. Rated Insulation Level
  - Power Freq. Withstand (Dry / Wet)   kV/   kV
  - Lightning / Switching Impulse Withstand Voltage   kV/   kV
- g. Insulator
  - Creepage Distance   mm
  - Color
  - Cemented Flange Type   Yes    No
- h. Transformation Ratio
- i. Rated Secondary Voltage Rating
  - No.1 Secondary Winding   V
  - No.2 Secondary Winding   V
  - No.3 Secondary Winding   V\*
- j. Rated Output
  - No.1 Secondary Winding   VA
  - No.2 Secondary Winding   VA
  - No.3 Secondary Winding   VA\*
  - Simultaneous   VA
  - Thermal of No.1/2/3 Secondary Winding   VA/   VA/   VA
- k. Rated Accuracy Class
  - No.1 Secondary Winding
  - No.2 Secondary Winding
  - No.3 Secondary Winding
- l. Total Weight   kg
- m. Volume of Oil   Litres

**Note:** \*Secondary winding for ferroresonance suppression (for reference).  
Information of the ferroresonance suppression shall be submitted for consideration.

**Remark**



Manufacturer's successful operation supply record in overseas country for Inductive Voltage Transformer

Manufacturer / Country : \_\_\_\_\_ / \_\_\_\_\_

Customer / Country	Qty.	Max. System Voltage (kV)	Basic Insulation level (kV)	Type / Model No.	Date of Operation	Attachment No.

The above information is to prove that manufacturer has experience conforming to that required by Article relevant to Eligibility of Bidders.  
 Bidders who propose equipment that has previously been accepted by EGAT, are exempted from completing this table.





**PART 3: DELIVERY SCHEDULE AND DISTRIBUTION LIST**

**INVITATION TO BID NO. NPUP-MJ1-02 and LPLC-MJ1-01**

**Delivery Schedule and Distribution List**

**Transmission System Development in the area of Nan Phrae and Uttaradit provinces for Power Purchase from Lao PDR Projects**

**Schedule A1 : 500 kV Coupling Capacitor Voltage Transformer**

Item No.	Description	Qty	Job no.	Substation	Delivery Required by EGAT (within months after confirmation of Letter of Award of Contract)
					CFR Thai Port / Ex-works / DDP EGAT's Store
A1-1	525 kV CCVT, 525000/√3 : 120/(120/√3) & 120/(120/√3) & 120/(120/√3) V, with carrier accessories, oil filled as per ratings and features RF PD9W1A	6	NPUP-01-S01	NA	12
A1-2	525 kV CCVT, 525000/√3 : 120/(120/√3) & 120/(120/√3) & 120/(120/√3) V, with carrier accessories, oil filled as per ratings and features RF PD9W1B	6	NPUP-01-S01	NA	12
A1-3	Steel Supporting Structure for PD9W1A (for item no.A1-1), H = 9.00 m. as per Dwg. No. ST-VT-9-01 and SD-AB-0-01	6	NPUP-01-S01	NA	12
A1-4	Steel Supporting Structure for PD9W1B (for item no.A1-2), H = 9.00 m. as per Dwg. No. ST-VT-9-01 and SD-AB-0-01	6	NPUP-01-S01	NA	12

Thai Port = BKK Port



**INVITATION TO BID NO. NPUP-MJ1-02 and LPLC-MJ1-01**  
**Delivery Schedule and Distribution List**  
**Long-Term Investment Plan to Accommodate Large Power Consumer**  
**Schedule B1 : 500 kV Current Transformer**

Item No.	Description	Qty	Job no.	Substation	Delivery Required by EGAT (within months after confirmation of Letter of Award of Contract)
					CFR Thai Port / Ex-works / DDP EGAT's Store
B1-1	550 kV CT, 2000-3000-4000/1A (6 cores), 50 kA, oil filled as per Rating and Features RF CT9AFAI	6	LPLC-01-S08	PDG	12
B1-2	550 kV CT, 2000-3000-4000/1A (6 cores), 50 kA, oil filled as per Rating and Features RF CT9AFDI	6	LPLC-01-S08	PDG	12
B1-3	Steel Supporting Structure for CT9AFAI (for item no.B1-1), H = 9.00 m. as per Dwg. No. ST-CT-9-01 and SD-AB-0-01	6	LPLC-01-S08	PDG	12
B1-4	Steel Supporting Structure for CT9AFDI (for item no.B1-2), H = 9.00 m. as per Dwg. No. ST-CT-9-01 and SD-AB-0-01	6	LPLC-01-S08	PDG	12

Thai Port = BKK Port



**DRAFT**

**SECTION D  
CONTRACT**

**CONTRACT**

**SUPPLY OF INSTRUMENT TRANSFORMER**

**TRANSMISSION SYSTEM DEVELOPMENT IN THE AREA OF NAN PHRAE AND  
UTTARADIT PROVINCES FOR POWER PURCHASE FROM LAO PDR PROJECTS**

**LONG-TERM INVESTMENT PLAN TO ACCOMMODATE LARGE POWER CONSUMER**

No. \_\_\_\_\_

This Contract is executed and delivered this \_\_\_\_\_ day of \_\_\_\_\_,  
B.E. \_\_\_\_\_ (A.D. \_\_\_\_\_), between

**ELECTRICITY GENERATING AUTHORITY OF THAILAND**

represented by \_\_\_\_\_ of said Authority, hereinafter called "EGAT", and

**(Contractor)**

represented by \_\_\_\_\_, age \_\_\_\_\_ years, nationality \_\_\_\_\_, hereinafter called  
the "Contractor".

EGAT and the Contractor mutually agree as follows :

**D-1. Contract Documents**

The following documents attached to this Contract are incorporated and made a part of this  
Contract, as though fully written out and set forth herein :

**Data Sheet**

- A. Invitation to Bid
- B. Instructions to Bidders
- C. Contract Price, Delivery Time of Equipment and Proposal Data
- D. Contract
- E. General Conditions
- F. Special Conditions
- G. Ratings and Features
- H. Bill of Materials (None)
- I. Specifications
- J. Drawings
- K. Supplemental Notices

L. Attachments :

---

---

---

M. Changes :

---

---

---

All of the foregoing documents are referred to herein as the Contract Documents. They are also incorporated into this Contract and made a part hereof all codes, designations, standards, standard specifications and similar Equipment which are referred to in the Specifications and Special Conditions.

**D-2. Acceptance of Proposal**

EGAT has accepted the proposal of the Contractor for furnishing the Equipment in conformity and in accordance with and subject to all the terms and conditions of these Contract Documents.

**D-3. Agreement**

The Contractor agrees to sell and EGAT agrees to buy the Equipment as described in these Contract Documents.

**D-4. Obligation of Contractor**

The Contractor agrees to perform well and faithfully all of the services and to furnish all of the Equipment described in these Contract Documents, and to supply and provide all Equipment, labor and other things requisite for or incidental to the said Work.

**D-5. Obligation of EGAT**

EGAT agrees, subject to the terms and conditions of these Contract Documents, to pay to the Contractor the amount shown, and at the rates and times and in the manner set forth in these Contract Documents.

**D-6. Mutual Obligations**

EGAT and the Contractor mutually agree to perform, fulfill, abide by, and submit to any and all of the provisions and requirements and all matters and things contained or expressed in, or reasonably to be inferred from these Contract Documents.

**D-7. Deposit of Performance Security**

The Contractor agrees to deposit with EGAT an acceptable performance security in accordance with the Contract Documents.

**D-8. Assignment**

The Contract or any part thereof shall not be assigned or pledged without the written consent of EGAT, nor shall the Contractor assign or pledge any money due, or to become due, to him hereunder, without the prior written consent of EGAT.

**D-9. Notices**

All notices called for by the terms of this Contract shall be effective only at the time of receipt thereof and only when received by the parties to whom they are addressed at the following addresses :

EGAT : Governor  
Electricity Generating Authority of Thailand  
Bangkruai, Nonthaburi 11130  
Thailand

Contractor : \_\_\_\_\_  
\_\_\_\_\_  
\_\_\_\_\_  
\_\_\_\_\_

All notices called for by the terms of this Contract shall be in the form of registered letters or *letters submitted electronically or electronic mails (E-mails)* in the English language.



DRAFT

**SECTION E**  
**GENERAL CONDITIONS**

## GENERAL CONDITIONS

### **E-1. Definitions**

Whenever the following terms are used in the Contract Documents, they will have the following meanings :

- EGAT : The Electricity Generating Authority of Thailand, having its Head Office at Nonthaburi, Thailand, and its authorized representative or representatives
- Engineer : Firm or company assigned by EGAT to provide engineering, consulting or construction management services in support of EGAT
- Bidder : Any person or firm or company or joint venture or consortium of firms submitting bid to EGAT for furnishing the services and Equipment described in the Contract Documents, in response to this Invitation to Bid
- Contractor : Any person or firm or company or joint venture or consortium of firms including appointed representatives, successors and assignees thereof, whose bid has been accepted by EGAT for furnishing of the services and Equipment described in the Contract Documents
- Subcontractor : Any person or firm or company (other than the Contractor) to whom any part of the Contract has been sublet, with the consent of EGAT, by the Contractor
- Contract : The agreement between EGAT and the Contractor, and all Appendices and Schedules thereto including Invitation to Bid, Instructions to Bidders, Proposal, General Conditions, Special Conditions, Specifications, Ratings and Features, Drawings, Supplemental Notices and any other documents referred to in, or connected with the Contract, eventhough the said documents are issued after execution of the Contract
- Contract Price : The sum specified in Section C which is inclusive of VAT (if any) subject to such additions thereto or deductions therefrom as may be made under the provisions hereinafter contained

Equipment	:	Machinery, apparatus, materials, goods, including accessories and spare parts to be supplied under the Contract and specifically described in the Specifications
Work	:	All the work to be done by the Contractor for design manufacture, shop test, transportation, and delivery of the Equipment ex-works, FOB Port of Shipment/Vessel or CFR Thai Port or at EGAT's store/site as agreed, including, if required, supervision for installation at site and supervision for field tests of the Equipment under the Contract
Thai Port	:	Commercial ports in Thailand including but not limited to Bangkok Port, Laem Chabang Port, Sriracha Harbour Port, Siam Seaport, Maptaphut Port, Songkhla Port, Phuket Harbour Port or Suvarnabhumi Airport, as the case may be
Bangkok Port	:	Bangkok Wharf (Klong Toey Port) and all other commercial ports in Bangkok Metropolitan area
Supervisor (if required)	:	Contractor's employee assigned as installation supervisor including assistant supervisor, to supervise and be responsible for the installation, erection, adjustment, field tests, and commissioning of the Equipment supplied under the Contract
Option (if any)	:	Equipment to be quoted by the Bidder which EGAT reserves the right to accept or omit in whole or in part
Year	:	Calendar year
Month	:	Calendar month
Day	:	Calendar day

## **E-2. Intent of Contract Documents**

All of the Contract Documents are complementary, and what is called for by one shall be as binding as if called for by all. In the case of any discrepancy between any of the Contract Documents, or any defective description or ambiguity, the matter shall be promptly submitted to EGAT, which shall promptly make a determination in writing. Any adjustment by the Contractor without this determination shall be at the Contractor's own risk and expense. In all cases of discrepancy, defective description, or ambiguities, the interpretation given by EGAT shall be binding on the Contractor, subject to the provisions of Article E-31. Dispute Resolution, included in these General Conditions.

**E-3. Applicable Law and Legal Jurisdiction**

The applicable law of this Contract shall be the law in force in the Kingdom of Thailand. Should there be any ambiguity or discrepancy arising out of or in connection with the Contract Documents, the interpretation thereof shall be made in accordance with Thai laws. Any litigations between the parties that may arise out of or in connection with this Contract or the breach or termination thereof or the performance of work thereunder shall be submitted to the Court of Thailand for decision, except as may be otherwise specifically provided in these Contract documents.

**E-4. Statutory Requirements**

Throughout the continuance of the Contract, the Contractor shall conform to all laws of the Kingdom of Thailand, and to all regulations, by-laws, ordinances, or orders made thereunder, and to the lawful requirements of any public, municipal, or other authority, in any way affecting or applicable to the Contractor or its operations.

**E-5. Patents and Copyrights**

The Contractor shall indemnify and hold EGAT, its officers, agents, and employees harmless against and from liability of any nature or kind, including costs and expenses for or on account of any copyrighted or uncopyrighted composition, secret process, patented or unpatented invention, article, or appliance manufactured, delivered, or used in carrying out the Work under the Contract. All drawings and the information contained therein as well as the use of any process, material or Equipment developed in the course of carrying out the Work under the Contract shall become the property of EGAT where EGAT shall have the right to use any or all of them for any purpose either for present or future projects. For the avoidance of doubt, none of them will be used solely for any commercial benefit which is not related to EGAT work.

**E-6. Subcontracts**

The Contractor shall not assign or transfer the Contract or any part thereof or any benefit or interest therein or thereunder, any monies due or become due under this Contract to any other person or persons.

The Contractor shall not be allowed to subcontract the whole of the Work under this Contract. Subcontracting of any part of the Work shall be subject to the prior written consent of EGAT. Such consent, if given, shall not relieve the Contractor from full and entire responsibility under this Contract.

If the Contractor desires to subcontract any part or parts of the Work called for by the Contract, he shall notify EGAT in writing to that effect and shall state in such notice the nature and extent of the part or parts of the Work called for by the Contract proposed to be subcontracted and name of the person proposed as Subcontractor. Unless and until written approval is given by EGAT, approval for which shall not be unreasonably withheld, the Contractor shall not subcontract any part of the Work. All requirements specified in these Contract Documents shall be applicable to Subcontractors also.

No contractual relation shall exist between EGAT and the Subcontractors, and the Subcontractors are not to enjoy any privileges conferred on the Contractor by this Contract.

Any Work done by any Subcontractor who has not been approved by EGAT shall be subject to rejection or stoppage of Work by EGAT. In such case the Contractor cannot claim delay or request for time extension of the Contract completion date and/or make financial claim to EGAT.

**E-7. Export Charges**

All tariffs, duties and other taxes or charges levied by the country of origin of the Equipment shall be paid by the Contractor, and such expenses shall be included in the cost of the Equipment.

**E-8. Import Duty and Taxes**

EGAT will pay all costs of procuring the necessary permits and licenses for importation into Thailand, and will pay import duty and any taxes including value added tax imposed at the port of entry on the Equipment to be supplied by the Contractor and imported into Thailand for the Work under this Contract.

EGAT will not pay import duty and taxes on either the personal effects of the Contractor's employees, such as personal articles, household furnishings and appliances, and goods of any kind imported for the personal use of the Contractor's employees whether imported by an employee or by the Contractor, or in respect of food, tobacco, liquor and other commissary goods imported by the Contractor or by his employees.

EGAT will not pay import duty and taxes including value added tax on equipment, tools, instruments and machinery imported by the Contractor for purpose of carrying out the work under the Contract. All processes of importation shall be arranged by the Contractor.

Equipment, tools, instruments and machinery which are certified by the Contractor that they are required for installation, test and commissioning of the Work at the site and they are intended for re-exportation can be temporarily exempted from import duty and taxes including value added tax. All Equipment thereof shall be imported under the name of the Contractor and be in accordance with the rules and regulations of the Customs Department of the Kingdom of Thailand.

EGAT will assist the Contractor for such temporary exemption of import duty and taxes including value added tax by issuing a letter confirming such temporary import. Import duty and taxes including value added tax for the temporarily imported Equipment shall be paid by the Contractor to the Customs Department before re-exportation at the rate to be specified by the Customs Department at the time of importation for the whole period they have been imported into the Kingdom of Thailand. Temporary importation of the Equipment is subject to approval of the Customs Department and the deposit of a bond with the Customs Department in the amount to be notified by the Customs Department is required. All costs for submission of information and data if required by the Customs Department and the cost of provision of the bond shall be borne by the Contractor.

In view of numerous advantages, the ATA Carnet system or other systems may be arranged for shipment of the said temporarily imported equipment by the Contractor (if required). Any charge incurred and/or any liability shall be borne by the Contractor.

#### **E-9. Value Added Tax**

Pursuant to the Revenue Code of Thailand, EGAT shall be responsible and pay when due for the value added tax imposed on the supply of Equipment, including local transportation (if any) and/or on the provision of services under this Contract. EGAT shall in no case be responsible for the value added tax collectible on any payment made by the Contractor under any subcontract or under any other circumstances and the Contractor shall comply with the rules and regulations of the Revenue Code of Thailand.

In case there is any change on the rate of value added tax imposed by the Government of Thailand, the amount of value added tax comprised in the Contract Price shall be adjusted to reflect such change, provided that the price of the Work shall remain unchanged.

#### **E-10. Income and Other Taxes**

Income and other taxes assessed or collected by the Government of Thailand, or any subdivision thereof, or any municipality therein on the Contractor and his employees shall be under the responsibility and account of the Contractor.

In accordance with the Revenue Code of Thailand, should the payment under this Contract be subject to income tax and withholding tax of any kind is required to be withheld by EGAT, such withholding tax shall be deducted by EGAT from each payment and EGAT will be responsible to remit such withholding tax to the Revenue Department of Thailand on behalf of the Contractor. In case any payment being made through the letter of credit or being made directly from foreign source whereby the withholding tax cannot be deducted from payment, the Contractor is required to immediately inform EGAT once each such payment is made to the Contractor, and the withholding tax of which will be paid from EGAT's own fund to the Revenue Department in the same manner as aforesaid. Such withholding tax amount as advanced by EGAT on behalf of the Contractor shall be reimbursed by the Contractor to EGAT within the period of time fixed by EGAT.

In the case where the Contractor considers that the transaction under this Contract is exempted from income tax of Thailand (under any circumstance), the Contractor shall submit, together with his proposal(s), a statement detailing such exemption and the valid documentary evidence. Should EGAT rely on the statement so submitted, no deduction for withholding tax shall be made from payment. However, if the tax authority of Thailand determines that such exemption is not applicable, the Contractor shall then be responsible for the amount(s) equal to the withholding tax, plus the amount(s) of tax exceeding those of withholding tax, including the surcharge and/or penalties imposed on EGAT and the Contractor. The responsibility and liability of the Contractor as provided in the preceding sentence shall survive termination of the Contract.

If the Contractor fails to immediately inform EGAT of the payment as required under the second paragraph preventing EGAT from remitting the withholding tax to the Revenue Department within seven (7) Days from the end of the month in which such payment is made, or fails to pay and/or reimburse EGAT for any amount required under this Article within the period of time fixed by EGAT, such period not to be shorter than fifteen (15) Days from the date of EGAT's notice for payment, EGAT has the right to claim directly from the Contractor or claim from Performance Security or Maintenance Security, as the case may be, or deduct or setoff from any money due to the Contractor under this Contract for the outstanding amount, surcharge and/or penalty (if any) together with interest at the

rate of Minimum Overdraft Rate (MOR) plus two (2) per cent calculated from the due date up to the date the payment is made in full.

EGAT will proceed with the tax matters under the Contract by relying on the information and document submitted by the Contractor in relation to the Bidder's status and tax liability. If the Revenue Department of Thailand differently determines the status and tax liability, the Contractor shall be responsible and liable for any cost and expense, penalty and/or surcharge incurred and/or imposed on him and EGAT in relation thereto.

#### **E-11. Fees and Duties**

Any and all immigration fees, stamp duties, and other fees assessed or collected by the Government of Thailand, or by any subdivision thereof, or by any municipality therein, on this Contract, on the Contractor and/or his personnel shall be paid by the Contractor. Any taxes collectible under this Contract, other than those stipulated in this Contract, shall be at the responsibility and account of the Contractor.

The stamp duty for any service contract (Construction, Hire of Work, Consultancy Service, Transportation, Supervisor, etc.) with the Contract value of the service portion lower than baht 200,000.- is required to be affixed by the Contractor on the original copy and the counterpart of the Contract. In case the value of the service portion is baht 200,000.- and over, payment of such stamp duty by the Contractor shall be made in cash to the Revenue Department of Thailand or its authorized subdistrict offices. In either case, the stamp duty is required to be affixed or paid, as the case may be, within fifteen (15) Days after the date of Contract execution, otherwise the Contractor shall be liable to pay for any and all penalties imposed for the delay as required by law.

The Contract value of the service portion to be calculated for stamp duty under this provision shall be the price excluding value added tax.

For a foreign Contractor who has no representative in Thailand, EGAT will, upon receipt of written request from the Contractor, affix or pay for stamp duties from EGAT's own fund on behalf of the Contractor, the Contractor is therefore required to reimburse EGAT for such stamp duties plus any and all penalties imposed by law for delay, if such delay is due to Contractor's failure to make written request to EGAT as aforesaid within a reasonable period of time.

If the Contractor fails to reimburse EGAT for any and all amount as required under this Article within the period of time fixed by EGAT, such period not to be shorter than fifteen (15) Days from the date of EGAT's notice for payment, EGAT has the right to claim directly from the Contractor or claim from Performance Security or Maintenance Security, as the case may be, or deduct or setoff from any and all money due to the Contractor under

this Contract for the outstanding amount together with interest at the rate of Minimum Overdraft Rate (MOR) plus two (2) per cent calculated from the due date up to the date the payment is made in full.

## **E-12. Performance Security**

The Contractor shall, at the time of execution of the Contract, deposit with EGAT a performance security for the due and proper performance of this Contract in the amount of ten (10) per cent, round up to the nearest whole number, of the total Contract Price. The performance security shall insure payment of any obligations, penalty, damages, liquidated damages, or expenses for which the Contractor may become liable to EGAT.

The amount of the performance security shall be adjusted or the Contractor may deposit a new performance security in the amount of ten (10) per cent, round up to the nearest whole number, of the additional Contract Price to cover the Contractor's obligation in case the Contract Price is increased due to change of the Work under the Article E-21. Changes and Extra or Omitted Work.

The performance security shall be in the form of a cash deposit, or a cashier cheque issued by a local bank, or a bank guarantee or letter of guarantee issued only by a local bank or an acceptable financial institution in Thailand, or by a foreign bank counter-guaranteed by a local bank and, made payable to EGAT in the same currency as that of the Contract. In case of a cash deposit or a cashier cheque, only Thai baht portion of the Contract Price can be made. EGAT may at any time, upon application by the Contractor, approve the substitution for any performance security held under this Article by other performance security on such terms and conditions as may be approved by EGAT. The Contractor shall bear the cost of the performance security.

The conditions of the guarantor's obligations in the performance security shall include, inter alia, the following :

- (1) The guarantor shall unconditionally guarantee, as primary obligor and not as surety merely, payment of any obligations, penalties, damages, liquidated damages, or expenses for which the Contractor may become liable to EGAT.
- (2) No extension of time, change in, addition to, or other modification of the terms of the Contract or Work to be performed thereunder, or of the specifications or other Contract Documents shall in anyway release the guarantor from any liability under the performance security, and the guarantor shall thereby waive notice of any such extension of time, change, addition or modification.
- (3) The performance security shall be valid and remain in full effect from the date of execution of the Contract until the issuance of the Acceptance Certificate by

EGAT or the acceptance of Equipment deemed to be made by EGAT against submission of the Maintenance Security accepted by EGAT.

Unless and until an official receipt is issued in respect to a security deposit, EGAT will not recognize or accept any such deposit as fulfilling the requirements of this Article. Failure to deposit a performance security at the time specified above in this Article or such extended time as may be approved by EGAT shall be a breach of this Contract and EGAT is entitled to terminate the Contract or suspend any payment for Work performed until the performance security has been accepted by EGAT. EGAT shall not be liable for any losses, expenses and/or damages resulting from such payment suspension.

If any performance security furnished under this Article becomes unacceptable to EGAT, or if any guarantor fails to furnish reports as to guarantor's financial condition from time to time, as requested by EGAT, the Contractor shall promptly furnish such additional or alternative security as may be required by EGAT from time to time to protect the interests of EGAT up to an amount equal to the amount of the security.

In the event of any default or breach of this Contract by the Contractor, EGAT may convert into money any performance security which does not consist of money, and the proceeds shall be deemed to be a cash deposit under this Article. EGAT shall not be liable for any cost, expenses and/or loss incurred in connection with such conversion.

The performance security, in case of a bank guarantee, or letter of guarantee, shall be in conformity with the specimen acceptable to EGAT as shown herein at the end of these General Conditions.

### **E-13. Inspection and Tests**

All Equipment furnished and all Work performed under this Contract shall be subject to inspection by EGAT or EGAT's authorized representatives at its option. while such Work is in progress to ascertain that the completed Work will comply in all respects with the standards and requirements set forth in the Contract Documents. Notwithstanding such inspection, the Contractor will be responsible for the acceptability of the finished Work.

EGAT or EGAT's representatives shall at all times have access to the Work whenever it is in preparation or progress and the Contractor shall provide proper facilities for such access and shall furnish promptly, without additional charge, all facilities, labor and material reasonably needed for safe and convenient inspection by EGAT or EGAT's representatives. The Contractor shall notify EGAT at least two (2) Months in advance when and where the Equipment and the Work will be available for each inspection and test. Any expense incurred by EGAT or EGAT's representatives to inspect the Equipment and

the Work or to attend the test caused by false call of the Contractor for inspection and tests shall be borne by the Contractor.

If any Work should be covered up, or otherwise made inaccessible, without the approval of EGAT, it shall, if required by EGAT, be uncovered and made accessible for examination. Any such cover, which is required in the finished Work, shall be restored to EGAT's satisfaction at the Contractor's expense.

The acceptance of any Work or Equipment covered by these Contract Documents, or the making or waiving of any inspection or witnessing of any tests shall in no way relieve the Contractor of full responsibility for the quality, character and satisfactory operation and performance of the complete Work, and every part of it, as outlined in these Contract Documents, nor shall it prejudice or affect the rights of EGAT as set forth in the Contract.

Unless otherwise specifically provided in the Contract, the expenses directly required for all labor, tools, instruments, other materials and Equipment necessary for performance of the tests shall be borne by the Contractor.

The Contractor shall at his own expense conduct shop tests in accordance with the Specifications and submit the results of the tests to EGAT upon completion of tests. EGAT reserves the right to inspect all Equipment either in person or via video conference during its manufacture or fabrication and prior to its preparation for shipment, to inspect its packing when ready for shipment, and to witness any or all tests.

In the event the results of the tests do not satisfy the requirements of the Specifications or the guaranteed performance, the Contractor shall rectify to improve the Equipment until satisfactory results are obtained and shall conduct all necessary retests at his own expense.

Any delay in delivery due to the retest shall not constitute a release of the Contractor from his responsibility for delay. Any expenses incurred by EGAT in attending these retests shall be borne by the Contractor.

EGAT reserves the right to send one or more of EGAT's employees, not as inspectors, to the Contractor's plant to witness the fabrication, assembly and testing of any or all parts of the Equipment being furnished under this Contract. Travelling expenses and per diem of such employee or employees shall be borne by EGAT.

#### **E-14. Preparation for Shipment and/or Delivery**

The Contractor shall submit shipment and/or delivery schedule for EGAT's approval at least thirty (30) Days in advance before each shipment and/or delivery is made. No shipment and/or delivery shall be made prior to EGAT's approval which will be notified to the Contractor within fifteen (15) Days after receipt of the said shipment and/or delivery schedule.

All imported and local Equipment to be delivered under this Contract shall be satisfactorily packaged in such a manner to protect them from damage during transportation and for outdoor storage at the site in hot, wet, humid and dusty conditions. In addition, the imported Equipment shall also be satisfactorily packaged for moist tropical ocean shipment. Where necessary, heavy parts shall be mounted on skids so that cable slings for handling can readily be attached. Where it is unsafe to apply external slings to a package, attached slings shall be provided and shall project through the package so that attachment can readily be made.

In order to keep the damage to non-water proof Equipment during the transportation at minimum level, the Contractor and/or supplier is required to put an umbrella mark on every package of the Equipment.

In order to accelerate the dispatch of the Equipment to the site, the Contractor is required to arrange packaging of the Equipment in such a manner that a complete set of one unit shall be packed in package(s) or crate(s) with indication of designated substation but each individual package or crate shall contain the Equipment for only one unit or part of a complete set of one unit or otherwise as directed in the Instructions for Packaging attached at the end of Section E. General Conditions.

For Power Transformer and Shunt Reactor, in addition, all accessories, which are packed in aforesaid manner shall be contained in a container per transformer except for transformer insulating oil, radiators and conservator including other accessories which for dimensional reason after packaging are unable to be contained in the said container. However, spare parts shall be contained in a separate container per each shipment or Contract to be awarded. The containers to be used shall become the property of EGAT. The dimensions of containers shall be as follows : -

<u>Container Dimensions</u>	<u>Door Dimensions</u>
Height 2.59 m.	Height 2.28 m.
Width 2.44 m.	Width 2.33 m.
Length 6.05 m.	

In addition, details of Equipment and substation destination per container shall be identified in Bill of Lading.

Detailed breakdown prices for spare parts of Equipment shall be also indicated in the invoice.

Prior to delivery of all Equipment, packaging details shall also be submitted to EGAT for approval.

The cost incurred for repair or replacement of any damages to the Equipment due to improper packaging shall be at the Contractor's expense.

Each individual package or crate shall be clearly and plainly tagged or marked for identification as follows:

EGAT, THAILAND

PROJECT NAME : \_\_\_\_\_

CONTRACT NO. : \_\_\_\_\_

SUBSTATION : \_\_\_\_\_

CASE NO. : \_\_\_\_\_

ITEM NO. : \_\_\_\_\_

DESCRIPTION : \_\_\_\_\_

EGAT'S SERIAL NO. : \_\_\_\_\_ (if any)

In addition to this, the following instructions shall be observed :

- a. Each box, crate, case, bundle or piece of loose Equipment shipped must show the following information clearly marked on its body :
  1. Gross weight in kilograms
  2. Net weight in kilograms
  3. Dimensions in centimeters
- b. All boxes, crates, cases, bundles, loose pieces, etc. must be marked consecutively from No. 1 upward throughout all shipments to completion of the order without repeating the same number.
- c. The packing list must indicate whether shipment is partial or complete, and shall incorporate the following information on each container, etc., according to its individual shipping number:
  1. Export case markings
  2. Case number
  3. Container number (for Power Transformer and Shunt Reactor)
  4. Item number
  5. Gross weight and net weight in kilograms
  6. Dimensions in centimeters
  7. Complete description of Equipment
  8. EGAT's serial No. (if any)

### **E-15. Clearance and Weight Limitations**

The largest unloading facilities at Bangkok Wharf are 35 metric ton cranes. Lifts heavier than 35 tons will have to be handled by ocean freighter on-board lifting equipment. Ocean freighters of the 10,000 tons class regularly calling at Bangkok Wharf have off-loading capacities to handle 50 tons.

The largest unloading facilities at Laem Chabang Port are 30 metric ton cranes. Lifts heavier than 30 tons will have to be handled by ocean freighter on-board lifting equipment.

Generally, unloading at Thai Port and highway transportation are subject to the following limitations:

Dimensions	Limitations		
	Unloading at Bangkok Wharf/ Highway Transportation		Unloading at Laem Chabang Port/Maptaphut Port
Weight (tons)	60.0	>60.0-135.0	120.0
Width (meters)	3.5	3.5	4.5
Length (meters)	10.0	10.0	25.0
Height from Loading Platform (meters)	3.7	4.0	4.0

The Contractor shall therefore exercise due care to pack the Equipment to meet the above transport limitations.

For Power Transformer and Shunt Reactor, the shipping weight of the largest part is indicated in Ratings and Features.

### **E-16. Shipment**

Shipment of Equipment from port of embarkation to the final port of discharge shall be effected by using Thai vessels through the sea freight forwarder appointed by the Contractor. The Contractor is required to notify EGAT of the name of the sea freight forwarder one (1) week prior to shipment.

According to the regulations of *the Maritime Promotion Division*, Marine Department (as amended from time to time), shipments by non-Thai vessels can be made after receipt of permission granted by *the Maritime Promotion Division*, Marine Department as requested by the Contractor.

The Contractor is, therefore, required to immediately contact *the Maritime Promotion Division*, Marine Department for such permission with supporting documents of the case thereof for arrangement of the permission in advance.

The Contractor shall follow all other regulations stated in the Mercantile Marine Promotion Act B.E. 2521 and the regulations of *the Maritime Promotion Division*, Marine Department (as amended from time to time).

The Contractor shall be liable for any and all costs and expenses, losses and/or damages suffered by EGAT as a result of the Contractor's failure to comply with such regulations.

For more information, the Contractor may contact *the Maritime Promotion Division, Marine Department at telephone No. 66 2233 1311-8 extension 387 and facsimile No. 66 2639 4778, <https://maritimepromotion.md.go.th/>*

All imported Equipment shall be shipped on Conference Line or on seaworthy oceangoing vessels which are members or associate members of the International Association of Classification Societies (IACS) and ISM Code Certified Vessels. Vessels over fifteen (15) years of age shall not be used for shipment under this Contract unless they : -

- a) have been used for the carriage of general cargo on an established and regular pattern of trading between a range of specified ports and do not exceed twenty-five (25) years of age, or
- b) were constructed as containerships, vehicle carrier or double-skin open-hatch gantry crane vessels (OHGCs) and have been continuously used as such on an established and regular pattern of trading between a range of specified ports, and do not exceed thirty (30) years of age.

Shipment shall be made under deck except for such Equipment which for dimensional reasons cannot be stowed in the vessels hold. In case Equipment cannot be stowed in the vessel hold, permission shall be obtained from EGAT prior to loading such Equipment on deck. Such approval shall not be unreasonably withheld. The Contractor shall in any case be responsible for proper packing for protection of such Equipment loaded on deck of the vessel. Shipment of all Equipment by dry cargo container will be accepted, but all the incidental expenses shall be borne by the Contractor.

For shipment of Equipment under this Contract, transshipment is allowed.

Any delicate Equipment, materials, instruments and tools including but not limited to computers, electronic parts, etc., shall be shipped by airfreight. The Contractor shall be responsible for proper packing for protection of such Equipment loaded on cargo hold of the aircraft.

Air freight shipment to airport of disembarkation in Thailand shall be effected through the air freight forwarder appointed by the Contractor. The Contractor is required to notify EGAT of the name of the air freight forwarder one (1) week prior to shipment.

#### **E-17. Documents Required for Each Shipment**

##### **a. For Seafreight**

For accounting procedure, the Contractor is required to send to EGAT the bill of lading, invoice and master packing list immediately by *letter submitted electronically or by electronic mail (E-mail)* but not later than three (3) Days after the Equipment are actually loaded free on board (FOB Vessel) at the port of Shipment.

One (1) original negotiable bill of lading, three (3) original signed invoices and packing lists shall be mailed directly to EGAT by express airmail within four (4) working days after the date of departure of the ocean-going vessel from the port of shipment.

Two (2) original negotiable and five (5) copies of non-negotiable bill of lading, ten (10) original signed invoices and three (3) copies of packing lists shall be submitted to EGAT through the Bank within the time as specified in the letter of credit. - This requirement is applied only in case payment is made by letter of credit.

##### **b. For Airfreight**

For accounting procedure, the Contractor is required to send to EGAT the airway bill, invoice and master packing list immediately by *letter submitted electronically or by electronic mail (E-mail)* but not later than three (3) Days after the Equipment are actually loaded on the air carrier at the airport of departure.

Three (3) original signed invoices and packing lists shall be attached to the airway bill and dispatched together with the airfreight shipment.

One (1) copy of airway bill, two (2) original signed invoices and packing lists shall be sent directly to EGAT by courier within four (4) working days after the date of departure of the carrier from the airport.

Two (2) copies of airway bill, ten (10) signed invoices and three (3) copies of packing lists shall be submitted to EGAT through the bank within the time as

specified in the letter of credit. - This requirement is applied only in case payment is made by letter of credit.

To act in accordance with the rules and regulations of the Customs Department of the Kingdom of Thailand, as well as to enable EGAT to expedite clearing the Equipment from the Customs House accordingly, the following declarations, other than regular statements, have to be made in English in the invoice for any transaction concluded with EGAT.

- a. Country from which Equipment is purchased as well as country of origin; if the Equipment is produced in the country or group of countries where there are trade agreements between such country or group of countries and the Kingdom of Thailand, preferential treatment on import duty and taxes for importation of the Equipment is required;
- b. Electricity Generating Authority of Thailand as consignee and Thailand as consigning country
- c. Date and Number of Contract;
- d. Name of Project, if any;
- e. Marking and numbers, as well as gross weight and volume;
- f. Details of Equipment, i.e. names, kinds, qualities, quantities, net weights, and other particulars as available for each type including trademarks or other symbols of such Equipment. If there are no trademarks or symbols, the invoice shall indicate "no trademarks", "no symbols", as the case may be;
- g. Selling price or value of Equipment per unit expressed in the type of currency under transaction and representing actual price or value of Equipment as stated in the price schedules or price breakdown, as the case may be;

If the Contractor fails to specify the price or value of Equipment according to the Contract in the invoice prepared for shipment, the Contractor shall be held responsible for the following:

1. In case of over value or price of Equipment stated in the invoice, the Contractor shall be responsible for reimbursement to EGAT for the import duty and taxes (excluding value added tax) collected by the Customs Department and the insurance premium (excluding value added tax) on the over value or price of Equipment as well as interest. Value added tax imposed in connection thereto shall be EGAT's responsibility. The Contractor shall also refund to EGAT the amount of over value payment as well as interest. The interest to be applied under this Article shall be Minimum Overdraft Rate announced by Krung Thai Bank plus two (2) (MOR+2) percent calculated from the date of EGAT's payment of the over value payment, import duty and taxes as well as insurance premium until the date of the Contractor's settlement of the same in full.
2. In case of under value or price of Equipment stated in the invoice, the Contractor shall be responsible for reimbursement to EGAT the surcharges

imposed on additional import duty and taxes at the rate currently established by the Customs Department as well as interest (if any) and also shall be responsible for compensation to EGAT for cost incurred in repair or replacement of the damaged Equipment which is not covered by insurance due to under value or price of Equipment stated in the invoice.

- h. Other expenses:
1. Packing charges (if any)
  2. Insurance premiums (if insured)
  3. Freight
  4. Others (if any)

The Contractor shall, at the time of shipment, prepare and submit a certificate of origin(s) for the Equipment required as per point a. above together with the invoice and other shipping documents for EGAT to obtain the benefit from preferential treatment on import duty and taxes for importation of the Equipment from the country or group of countries where there are trade agreements between such country or group of countries and the Kingdom of Thailand. For each shipment, all items of Equipment requiring certificate of origin shall be included in only one (1) certificate of origin except as otherwise specified in any trade agreement. The trade agreements shall include but not be limited to the following:

1. Common Effective Preferential Tariff (CEPT) Scheme for the ASEAN Free Trade Area (AFTA);
2. Agreement between the Kingdom of Thailand and Japan for an Economic Partnership; and
3. Agreement between the Government of the Kingdom of Thailand and the Government of the People's Republic of China on Accelerated Tariff Elimination under the Early Harvest Programme of the Framework Agreement on Comprehensive Economic Cooperation between ASEAN and China.

If the Contractor advises EGAT in writing before shipment that it is unable to provide a certificate of origin to EGAT, the Contractor shall be responsible for all costs incurred including but not limited to reimbursement to EGAT for the excess amount of the import duty and taxes (except value added tax) paid by EGAT to Customs Department.

Further to the above, if the Contractor delays to provide a proper certificate of origin to EGAT, the Contractor shall be responsible for all costs incurred including but not limited to reimbursement to EGAT for the storage charges and the interest on the excess amount of import duty and taxes (except value added tax) paid by EGAT to the Customs Department at the rate of Minimum Overdraft Rate announced by Krung Thai Bank plus two (2) (MOR+2) percent calculated from the date of EGAT's payment of import duty and taxes up to the date of receipt of the excess amount of import duty and taxes refund from the Customs Department.

However, if the Contractor fails to provide such proper certificate to EGAT, the Contractor shall be responsible for all costs incurred including but not limited to reimbursement to EGAT for the storage charges and the excess amount of import duty and taxes (except value added tax) paid by EGAT to the Customs Department as well as

interest on the said excess amount of import duty and taxes at the rate of Minimum Overdraft Rate announced by Krung Thai Bank plus two (2) (MOR+2) percent calculated from the date of EGAT's payment of import duty and taxes up to the date of acknowledgement that the certificate cannot be issued in conformity with requirement of the Free Trade Agreement.

The Contractor is also required to study the existing trade agreements and any new trade agreement between the Kingdom of Thailand and a country or group of countries published in the website of Customs Department ([www.customs.go.th](http://www.customs.go.th)) and/or Ministry of Commerce ([www.moc.go.th](http://www.moc.go.th)), and ask for more information from EGAT in order that EGAT can obtain the benefit from preferential treatment on import duty and taxes for importation of the Equipment from the country or group of countries where there are trade agreements between such country or group of countries and the Kingdom of Thailand.

Fullest conformity with the requirements of the Customs Department of the Kingdom of Thailand mentioned above is essential as a condition precedent.

Unless by force majeure, failure to furnish EGAT with these shipping documents and the certificate of origin within the specified period and strictly in accordance with conditions stipulated above thereby causing impossibility of making prompt customs clearance of the Equipment from Thai Port, the Contractor shall, upon receipt of the EGAT's notice, reimburse EGAT for go down rent / storage charge and other expenses arising from or in consequence of the nonconformity with the above specified requirement.

#### **E-18. Force Majeure**

The Contractor shall not be in default under this Contract because of any delays in delivery or in completion of the Work on the separable parts thereof which delays are caused by force majeure; provided, that the Contractor shall notify EGAT in writing of the cause of any such delay within fifteen (15) Days after the end of the event which results in the delay. Upon receipt of any such notice of delay, EGAT will promptly ascertain the facts and the extent of the delay and will extend the time for the delivery and assembly of the Equipment or the time for completing the Work when, in the opinion of EGAT, the delay is caused by force majeure or the findings of fact to justify an extension. EGAT's decision shall be binding on the Contractor, subject to the provision of Article E-31. Dispute Resolution included in these General Conditions.

"Force Majeure" shall be defined as any event, the happening or pernicious results of which could not be prevented even though a person against whom it happened or threatened to happen were to take such appropriate care as might be expected from him in this situation. (Normal rains, inundation, dearth of water, and the overturning or sinking of barges in canals, rivers, or streams and similar events shall not be considered as force majeure).

**E-19. Transportation Insurance**

Transportation insurance from the port of shipment/from the Contractor's premise(s) to EGAT's Store and/or EGAT's site will be under the responsibility of EGAT.

**E-20. Transfer of Title**

The title of ownership for the Equipment furnished under this Contract shall be passed to EGAT at the time the Equipment is actually loaded onto the vessel at the port of shipment, or into charge of the air carrier at the port of departure, or at the time the Equipment is actually delivered ex-works and the Contractor's statement or delivery order confirming delivery of the Equipment ex-works has been certified by EGAT's representative. However, this transfer of title shall not be construed as an acceptance of the Equipment. The Contractor shall continue to be responsible for the quality and performance of the Equipment, and for their compliance with the Specifications as well as any loss, theft or damage of the Equipment during the course of execution of the Contract, until final acceptance of the Work by EGAT and the fulfillment of the guarantee provision of the Contract.

**E-21. Changes and Extra or Omitted Work**

EGAT may at any time authorize changes in, additions to, or deductions from the Equipment to be furnished under the Contract. Changes, additions, or deductions shall be authorized only by written notice served by EGAT upon the Contractor and such notice shall be treated as an integral part of the Contract. Adjustments, if any, in the amounts to be paid to the Contractor by reason of any such change, addition, or deduction shall be determined by one or more of the following methods :

- a. by unit price contained in the Price Schedules
- b. by an acceptable lump sum or unit price proposal from the Contractor
- c. on a cost-plus limited basis not to exceed a specific limit. A cost-plus limited basis is defined as the cost of Equipment, labor, and insurance, plus fifteen (15) per cent of the said cost to cover superintendence, general expense, and profit.

No claim for an addition to the Contract Price shall be valid unless authorized as described in this Article. If the parties are unable to agree to the method to be employed in determining adjustments in the Contract Price, the method shall be determined by EGAT.

**E-22. Termination and Suspension of Contract**

EGAT may, by written notice sent to the Contractor, terminate the Contract, in whole or in part, at any time for its convenience. The notice of termination shall specify that termination is for EGAT's convenience, the extent to which performance of work under the Contract is terminated, and the date upon which such termination becomes effective.

The Equipment that are completed and ready for shipment within thirty (30) Days after the Contractor's receipt of notice of termination shall be purchased by EGAT at the Contract terms and prices. For the remaining Equipment, EGAT may elect :

- a. to have any portion completed and delivered at the Contract terms and prices and/or
- b. to cancel the remainder and pay to the Contractor an agreed amount for partially completed Equipment and for materials and parts previously procured by the Contractor.

**E-23. Default and Termination**

Should the Contractor :

- a. fail to furnish the Equipment or carry out the Work in accordance with this Contract; or
- b. refuse or fail to prosecute the Work or any part thereof which shall ensure its completion within the time specified in this Contract or any authorized extension of time by EGAT; or
- c. fail to furnish the Equipment and/or complete the Work or any part thereof within the time specified in this Contract or any authorized extension of time by EGAT; or
- d. commit any breach or fail to comply with any of the provisions of this Contract; or
- e. notify EGAT in writing that the Contractor is unable or unwilling to furnish the Equipment or complete the Work or any part thereof; or
- f. become insolvent or bankrupt or make an arrangement or composition with the Contractor's creditors or, being a corporation, go into liquidation whether compulsory or voluntary (except for the purpose of reorganization); or
- g. by himself or by any person on his behalf, give or offer any money or benefit of forbearance to any employee of EGAT and/or any employee of the Engineer who has duties or responsibilities in connection with the acceptance of the proposal or the making of this Contract;

then, in any of such events, the Contractor shall be in default under this Contract, and EGAT may at his sole discretion take any one or more of the following actions that it considers appropriate :

- (i) suspend payments under this Contract until the default has been rectified;
- (ii) cancel or terminate the Contract in whole or in part;
- (iii) take that part of the furnishing of Equipment or the Work, in respect of which the delay or default has occurred, out of the hands of the Contractor or any other person in whose control or possession it is;
- (iv) reduce the Contract Price by an amount equal to the reduction in value to EGAT of the Equipment as actually delivered.

The Contractor shall be liable for all losses and/or damages including but not limited to the increased installation costs and increased administrative costs, suffered by EGAT as a result of the Contractor's default. The Contractor shall have no claim for payment with respect to Work thereafter performed.

All such damages may be recovered by EGAT from the Contractor in any court of competent jurisdiction or, without prejudice to that right, by deduction from any money due or becoming due to the Contractor under this Contract, or from any security deposited, or, after use of the property and materials of the Contract for completion of the work, as provided in this Contract, such property and materials may be sold and the proceeds shall be applied to any remaining obligations of the Contractor.

#### **E-24. Indemnification by the Contractor**

The Contractor shall fully indemnify and hold harmless EGAT and its employees and officers from and against any and all suit, actions or administrative proceedings, claims (including any claim for copyright or patent infringement), demands, losses, costs, expenses (including attorney's fees and expenses) and damages of whatsoever nature except breach or default, in respect of death or injury of any person or loss of or damage to any property caused by any act or omission of the Contractor or the Contractor's own officers, directors, agents, employees, Contractors or Subcontractors arising in any manner whatsoever, except any injury, death or property damage caused by the negligence of EGAT, its contractors, employees, officers or agents.

**E-25. Limitation of Liability**

The liability of the Contractor to EGAT arising from default or termination under the Contract in aggregate shall not exceed the total Contract Price.

**E-26. Consequential Damages**

Neither party shall be liable to the other party for any indirect, incidental, consequential or punitive damages as a result of the performance or nonperformance of the obligations imposed pursuant to this Contract, unless such indirect, incidental, consequential or punitive damages are foreseen or could have been foreseen at the time of execution of the Contract.

**E-27. Vesting of Contract in Receiver**

If the Contractor shall compound with his creditors, or shall become bankrupt or insolvent, or carry on business under a receiver, or become incapable from any cause whatsoever of carrying out the Work, any such receiver or any person in whom by law the Contract shall become vested, shall forthwith give notice to EGAT of the fact that the Contract has become vested in it and shall take all reasonable steps to carry on the Work at a rate fulfilling the Contract requirements. Thereupon, if EGAT so desires, such receiver or other such person as aforesaid shall have the option, during the period of one (1) Month from the date when the Contract becomes so vested in it, of carrying out the Contract. In the event of the Work being stopped, this option shall be opened only for a period of fourteen (14) Days from the stoppage date. In the event of the receiver or such other person not electing to carry out the Contract or EGAT not approving the carrying out of the Contract by the receiver, the Contractor shall then be in default and EGAT may proceed in accordance with Article E-23. Default and Termination.

**E-28. Extension of Time**

If, by reason of any of the following :

- a. Negligence or default on the part of EGAT or its agents,
- b. Alteration in or addition to the Work,
- c. Suspension of the Work at the written direction of EGAT for reasons beyond the control of the Contractor,
- d. War, insurrection, riot or civil commotion or delay caused thereby,
- e. Strikes, not caused by the Contractor's management,
- f. Lawful order of civil or military authorities,
- g. Unusually natural calamities, acts of God,
- h. Any other unforeseen circumstance beyond the Contractor's control.

The Contractor claims that he has been unduly delayed in the progress of the Work, he shall make written request to EGAT for an extension of time for completion of the Work or any portion of it.

Should EGAT consider such claim to be valid, it will grant such extension of time as may seem reasonable to EGAT, without thereby prejudicing or in any manner affecting the validity of the Contract. No extension of time will be granted unless the Contractor makes the written request within fifteen (15) Days after the end of the event which results in the delay.

Other than claiming an extension of time for completion of the Work or any portion of it, the Contractor shall not have any further recourse or claim against EGAT, nor shall he have any right of action against EGAT for loss or damage suffered by reason of such delay.

**E-29. Failure to Meet Requirements**

EGAT shall have the right to require the Contractor to make any changes in the Equipment or Work covered by this Contract, which may be necessary in the opinion of EGAT, to make the Equipment or Work conform to the requirements of the Contract Documents, without additional cost to EGAT. Any defects in the Equipment or workmanship or other failure, to meet the requirements of the Contract, including errors and omissions on the part of the Contractor, which are disclosed prior to final payment or prior to acceptance by EGAT, or after completion of all tests, whichever occurs at the later date, shall, if so directed by

EGAT, be corrected or replaced promptly by the Contractor at the expense of the Contractor.

In case of replacement of Equipment due to non-conformity with EGAT's specifications and/or defects found prior to acceptance of Equipment by EGAT or replenishment for short pack or returning of repaired Equipment due to such defect, the Contractor shall, upon receipt of EGAT's written notice supported with the receipt issued by the relevant parties, be responsible for reimbursement of the expenses incurred for the following :

- All re-export charges (if any)
- Import duty and taxes
- Landing charges, rents and handling charges (ocean freight)
- Storage charges (air freight)
- Truck hire
- Labour charges

These expenses shall exclude value added taxes, which will be EGAT's responsibility.

The contractor shall be also responsible for reimbursement of Service charges for customs clearance (if any) including value added tax.

Any latent defects not disclosed prior to the date of final payment or prior to acceptance or after completion of all tests, whichever occurs at the later date, but disclosed within the guarantee period as specified in Article F-10.a., shall be corrected or replaced promptly by the Contractor at the expense of the Contractor, except that the cost of import duty and taxes, inland transportation and installation of the replacement parts for foreign supply Equipment, and the cost of inland transportation and the installation of the replacement parts for local supply Equipment will be borne by EGAT.

For Equipment specified in Data Sheet, in case EGAT, at its sole discretion, requires the Contractor to replace any defected Equipment, the Contractor shall replace the Equipment with the whole new set at its own costs and expenses including the cost of all re-export charges (if any), import duty and taxes, landing charges, rents and handling charges (ocean freight), storage charges (air freight), truck hire, labour charges, service charges for customs clearance, inland transportation and installation of the Equipment.

The Contractor shall extend the provisions of his liability to cover all repair and replacement parts furnished from the day immediately following the date of completion of such repair or replacement as follows:

<b>Time of Malfunctioning and/or Defect Found</b>	<b>Guarantee Period Extension</b>				
	<b>Equipment with 1-Year guarantee period</b>	<b>Equipment with 2-Year guarantee period</b>	<b>Equipment with 3-Year guarantee period</b>	<b>Equipment with 4-Year guarantee period</b>	<b>Equipment with 5-Year guarantee period</b>
<b>First Year</b>	For a new period of one (1) Year.	For a new period of two (2) Years.	For a new period of three (3) Years.	For a new period of four (4) Years.	For a new period of five (5) Years.
<b>Second Year</b>	n/a	For a new period of one (1) Year.	For a new period of two (2) Years.	For a new period of three (3) Years.	For a new period of four (4) Years.
<b>Third Year</b>	n/a	n/a	For a new period of one (1) Year.	For a new period of two (2) Years.	For a new period of three (3) Years.
<b>Fourth Year</b>	n/a	n/a	n/a	For a new period of one (1) Year.	For a new period of two (2) Years.
<b>Fifth Year</b>	n/a	n/a	n/a	n/a	For a new period of one (1) Year.

The Contractor shall, if required by EGAT in writing, search under the directions of EGAT for the cause of any defect, imperfection or fault appearing prior to the acceptance of Equipment or in the period of maintenance guarantee. Unless such defect, imperfection or fault shall be one for which the Contractor is liable under the Contract, the cost of the work carried out by the Contractor in searching as aforesaid shall be borne by EGAT. If such defect, imperfection or fault shall be one for which the Contractor is liable under the Contract, the cost of the work carried out in searching as aforesaid shall be borne by the Contractor and he shall in such case repair, rectify and make good such defect, imperfection or fault at his own expense.

**E-30 Operation or Use of Unsatisfactory Equipment**

If the operation or use of the Equipment proves to be unsatisfactory to EGAT, EGAT shall have the right to operate and use such Equipment until they can be taken out of service for correction by the Contractor of such latent defects, error, or omissions and for replacement in whole or in part, if correction is unsuccessful or infeasible. The period of such operation or use shall not exceed one (1) Year from the day immediately following the date of acceptance of Equipment by EGAT.

**E-31. Dispute Resolution**

Any dispute arising out of or in connection with this Contract, interpretation, breach, or termination thereof shall be settled by amicable discussion between authorized representatives of each Party. Either Party may at any time send a written notice to the other Party requesting for an appointment of authorized representative for a settlement of any dispute hereunder. The Parties agree to make diligent and good faith attempt to resolve such dispute in an equitable manner. If the authorized representatives of both Parties are unable to resolve such dispute within 30 Days after commencement of the discussion for dispute resolution or other extended period of time as mutually agreed by both Parties, either Party may file a lawsuit to the court having jurisdiction in Thailand for settlement of such dispute. Each Party agrees that the final court judgment shall be conclusive and binding upon the Parties.

Pending decision of the court, both Parties shall continue to perform their respective obligations under this Contract.

**E-32. Language and Numbers**

All drawings, designs, specifications, manuals, nameplates, markings, operating instructions, statements, schedules, notices, documents, and all written communications between EGAT and the Contractor, concerning this Contract, shall be in the English language and in the metric system of weights and measures unless otherwise specified.

**SPECIMEN OF GUARANTEE**

To :

Date

Electricity Generating Authority of Thailand  
Bangkruai, Nonthaburi, 11130

Thailand

Re : Performance Security for Contract No. \_\_\_\_\_

Gentlemen :

In accordance with the provision of the Contract for \_\_\_\_\_ No. \_\_\_\_\_ (hereinafter referred to as the Contract) the contents of which have been noted by us that Messrs. \_\_\_\_\_ (hereinafter referred to as the Contractor) has to deposit with Electricity Generating Authority of Thailand (hereinafter referred to as EGAT) a Performance Security for the proper and faithful performance of the Contract in the amount of \_\_\_\_\_ (in words : \_\_\_\_\_) which is \_\_\_\_\_ per cent, round up to the nearest whole number, of the total Contract Price, we, the \_\_\_\_\_ as instructed by the Contractor, agree unconditionally to irrevocably guarantee as primary Obligor, the payment to EGAT on its first demand, without whatsoever right of objection on our part and without its first claim to the Contractor, in the amount not exceeding : \_\_\_\_\_ (in words : \_\_\_\_\_) in the event the obligations expressed in the above mentioned Contract have not been fulfilled by the Contractor, giving EGAT the right of claim for penalty, damages, liquidated damages or any expenses for which the Contractor may become liable to EGAT under the Contract.

We further agree that no extension of time, change in, addition to or other modification of terms of the Contract or Work to be performed thereunder, or of the Specifications or other Contract Documents, which may be made between EGAT and the Contractor, shall in any way release us from any liability under this guarantee, and we shall thereby waive notice of any such change, addition or modification.

This Performance Security shall be valid and remain in full effect from the date of execution of the Contract until the issuance of the Acceptance Certificate by EGAT or the acceptance of Equipment deemed to be made by EGAT against submission by the Contractor of the Maintenance Security accepted by EGAT.

Yours very truly,

\_\_\_\_\_  
Authorized Signature

### Instructions for Packaging

Name of Equipment	Packed per complete set of one unit/units	Packed per Substation
1. Power Transformer	√(1)	-
2. Distribution Transformer	√(1)	-
3. Shunt Reactor	√(1)	-
4. Surge Arrester	√(1)	-
5. Current Transformer	√(1)	-
6. CC, CCVT, VT	√(1)	-
7. GIS	-	√
8. Shunt Capacitor Bank	√(1)	-
9. Power Circuit Breaker	√(1)	-
10. Disconnecting Switch	√(1)	-
11. AC/DC Dist. Board, LCUS, LRP	√(1)	-
12. Stationary Battery	√(1)	-
13. Lighting Fixture	-	√
14. Identification and Danger Notice Plate	-	√
15. Control and Protection System	√(1)*	-
16. Computerized Control System	-	√
17. Power Line Carrier	-	√
18. Teleprotection	-	√
19. Line Trap	-	√
20. Battery Charger	√(1)	-

- Note :
1. Number in parenthesis represents maximum number of complete set of one unit/units packed in an individual package or crate.
  2. \* In case of spare for control and protection system, such Equipment shall be packed per board, but in case of loose control and protection system, such Equipment of whichever substation shall be packed in the same package or crate of that substation.
  3. Other substation Equipment not mentioned shall be packaged in such a manner that it will not cause unreasonable expenses or delay to EGAT in distribution of such Equipment to the designated substation.
  4. Prior to delivery of all Equipment, packaging details shall be submitted to EGAT for approval.

DRAFT

**SECTION F**  
**SPECIAL CONDITIONS**

## **SPECIAL CONDITIONS**

### **F-1. Scope of Work**

The Contractor shall perform, furnish and deliver the Equipment as required by these Contract Documents.

For imported Equipment, Transportation from Thai Port to sites shall be EGAT's responsibility. However, the Contractor shall, at his own expenses and responsibility, perform unloading the Equipment at the port or airport of disembarkation in Thailand.

For local supply, Transportation from the Contractor's premises to the sites shall be EGAT's responsibility. However, the Contractor shall, at his own expenses and responsibility, perform loading the Equipment on EGAT's trucks or trailers at the Contractor's premises and shall be liable for all losses and/or damages to the Equipment as well as any expenses causing therefrom.

### **F-2. Responsibility of Contractor**

The Contractor shall be solely responsible for ensuring that the Work throughout is executed in the most substantial, proper and workmanlike manner, with the best quality materials and conforming to the best engineering practice for the operating conditions specified; the drawings and quality control are performed or made in accordance with the Contract; and services reasonably to be furnished though not specifically provided in the Contract are furnished; all to EGAT's entire satisfaction notwithstanding that certain portions of the work may be executed by the Subcontractor.

### **F-3. Cooperation with Other Contractors**

The Contractor, if required, shall exchange with other Contractor furnishing associated Equipment, all necessary drawings and other information required to insure the complete and proper design and manufacture of the Equipment to be furnished under these Specifications. One (1) copy of all drawings and correspondence, relating to information interchanged between Contractors, shall be sent to EGAT in Nonthaburi, Thailand.

**\*F-4. Supervision of Installation**

Subject to the desire and decision of EGAT, the Contractor may be required to furnish the services of qualified and experienced supervisor(s) who has at least three years experience on the particular Work required under the Contract and shall be the permanent employee of the manufacturer of the Equipment. For 230 kV (or lower) Power Circuit Breaker and 115 kV (or lower) Gas-Insulated Switchgear, the permanent employee of the representative of the manufacturer is acceptable, provided that such employee is certified by the manufacturer.

The scope of responsibility of the supervisor on behalf of the Contractor is as follows :

- a. Supervise and be responsible for the installation, erection, adjustment, field test and commissioning of the Equipment.
- b. Prepare formulation sheets for a check list, test sheet, release form and field report to be discussed with EGAT before performing the installation work.
- c. Submit four copies of report summarizing the work performance, from the beginning to the completion of the supervisory period, to EGAT within one month after finish the installation work or final inspection. The report shall include the following :
  1. Note on pending matter i.e. faulty and omitted equipment, performance deficiency etc.
  2. Problem concerning installation performance.
  3. Photographs showing progress of the installation work periodically until the work is completed.

The Contractor shall, in each and every instance, cooperate fully with the construction personnel installing and/or operating the Equipment and the Work, the operations of the supervisor shall be coordinated with the program of construction at the site as directed by EGAT.

The supervisor shall report at EGAT in Nonthaburi, Thailand, on the date designated by EGAT after a reasonable advance notice from EGAT, and shall remain until the Equipment have been in satisfactory operation for at least ten (10) working days as determined by EGAT, unless released earlier by EGAT.

The installation supervisor must be able to understand, speak, read and write the English language fluently. Should an interpreter be necessary, the cost of such interpretation service shall be at the Contractor's expense.

\*If installation supervisor is required as specified in Price Schedule, this provision shall apply to this Contract.

**F-5. Acceptance Tests**

After the Equipment have been installed and placed in satisfactory operation, they may be tested by and at the expense of EGAT to determine whether or not all requirements of these Contract Documents have been met and the Contractor's guarantees have been fulfilled. The Contractor will be permitted to have his representative present at his own expense. If the tests show that the requirements or guarantee have not been met, the Contractor shall, at his own expense, make all necessary corrections. Additional tests will then be made to demonstrate to EGAT's satisfaction the effectiveness of these corrections. These additional tests will be at the Contractor's expense. Unless the necessary corrections have been made, the conditions of the Contract shall be considered unfulfilled.

All tests will be performed in accordance with the latest applicable Test Codes, unless otherwise stated.

**F-6. Failure to Meet Performance Guarantees**

If EGAT elects to accept the Equipment which do not meet any performance guarantee or which do not meet other requirements of these Contract Documents, as may be determined by factory test, field test or operation under service conditions, appropriate adjustment will be made of the Contract Price for such Equipment; provided that no such adjustment will be made until after the Contractor has been given a reasonable opportunity to repair, improve, or replace defective Equipment or parts thereof wherever practicable.

**F-7. Acceptance Certificate**

When EGAT is satisfied with the Equipment or agrees to accept the Equipment under the provision of Article F-6. Failure to Meet Performance Guarantees and there are no major unsettled claims against the Contractor by EGAT, EGAT will issue a written Acceptance Certificate against submission by the Contractor of maintenance security(ies) as specified in Article F-12. Maintenance Security and effective for a period of time as specified in Article F-10.a.

The Acceptance Certificate will list all deficiencies and reservations as a result of the inspection and tests performed, if any.

The purpose of the maintenance security is to guarantee the proper functioning of the Equipment supplied by the Contractor with a provision that the effective period of the maintenance security shall automatically be extended in case that the obligations stipulated in Article F-10. Maintenance Guarantee are not fulfilled.

A form of maintenance security acceptable to EGAT is shown in Article F-12. Maintenance Security.

## **F-8. Payment**

Payment in foreign currency will be made in the currency or currencies in which the price has been stated in the price schedules. The Contractor has to inform EGAT the mode of payment he requires for payment for foreign currency portion together with detail of bank account No., beneficiary's name and address etc. If the Contractor requires the payment of foreign currency portion to be paid directly to the suppliers, he has to inform EGAT which portion of the Contract Price, as stipulated in the term of payment of the Contract, to be paid accordingly. In case the local Contractor requires foreign currency or currencies to be paid directly to him, payment of such foreign currency or currencies will be made to the local Contractor in Thai Baht by using the selling exchange rate published by the Bank of Thailand on the payment date.

In case the Contractor requires the payment of foreign currency portion to be made through letter of credit, EGAT will, if there is no fault or any delay caused by the Contractor, establish the letter of credit in the name of the Contractor or Suppliers not later than thirty (30) Days after signing the Contract. The Contractor shall be responsible for all bank charges inside and outside Thailand and including opening, amendment, reimbursing charges, payment commission, cable charges, discrepancy fee, acceptance commission and others (if any) arising from Letter of Credit.

Payment in local currency will be made directly by EGAT.

The Contractor or beneficiary has to inform EGAT by mailed letter or *letter submitted electronically or by electronic mail (E-mail)* immediately the date upon which he has received the original letter of credit *to be* opened in his favour.

Payment will be made in the following manner :

### **a. Payment for Equipment (except Spare Parts and Optional Items)**

#### **Foreign Supply**

1. Eighty (80) per cent of the Contract Price will be paid after delivery FOB Port of Shipment (FOB Vessel) on the basis of pro rata value of each shipment against presentation of invoices, shipping documents, EGAT's letters of approval for shipment and EGAT's letter of approval for test report\* of the relevant Equipment including EGAT's letter(s) of approval for final drawings only for Control and Protection Equipment.

\*Test report means the report of tests specified in Article E-13. Inspection and Tests.

2. Ten (10) per cent of the Contract Price of each Schedule will be paid against presentation of Drawing and Document Acceptance Certificate to be issued by EGAT to certify the receipt of all drawings and documents required from the Contractor under Article F-11. Drawings and Documents to be Furnished by Contractor for such schedule, provided that payment shall not be made until EGAT has received from the Contractor the original signed negotiable Bill of Lading and appertaining documents giving evidence of shipment of the main Equipment of that Schedule.
3. Ten (10) per cent of the Contract Price of each Schedule will be paid after the Equipment have been installed, tested and operated or used for a period of 30 Days and the acceptance of the said Equipment has been made by EGAT against presentation of Acceptance Certificate to be issued by EGAT and submission of maintenance security by the Contractor. EGAT will list the minor pending claim(s), if any, and payment will be made by deducting such claimed amount.

However, if, through no fault of the Contractor or of the Equipment, such installation, test and operation or use of the Equipment are delayed beyond a period of six (6) Months after complete delivery at Thai Port; payment of this ten (10) per cent will be made as soon as possible but not later than the ninth (9<sup>th</sup>) Month after complete delivery and it shall be deemed as if acceptance of Equipment is made by EGAT at the end of the said sixth (6<sup>th</sup>) Month and the guarantee period shall start therefrom against submission of maintenance security by the Contractor.

In case there is some minor claim(s) or minor fault of the Contractor, the payment of this ten (10) per cent shall be made by deducting such claimed amount and the guarantee period of this part will start after such minor claim(s) has been settled by the Contractor and acceptance of which has been made by EGAT.

### **Local Supply**

1. Eighty (80) per cent of the Contract Price will be paid on the basis of pro rata value of each delivery against presentation of the Contractor's statement or delivery order confirming the ex-works delivery of Equipment duly certified by EGAT's representative\*, EGAT's letters of approval for delivery and EGAT's letter of approval for test report\*\* of the relevant Equipment including EGAT's letter(s) of approval for final drawings only for Control and Protection Equipment.

\*EGAT's representative means the authorized EGAT's Store personnel to verify the quantity of Equipment according to the packing list to be delivered to the Site.

\*\*Test report means the report of tests specified in Article E-13. Inspection and Tests.

2. Ten (10) per cent of the Contract Price of each Schedule will be paid against presentation of Drawing and Document Acceptance Certificate to be issued by EGAT to certify the receipt of all drawings and documents required from the Contractor under Article F-11. Drawings and Documents to be Furnished by Contractor for such schedule, provided that payment shall not be made until EGAT has received from the Contractor the statement or delivery order and appertaining documents giving evidence of delivery of the main Equipment of that Schedule.
3. Ten (10) per cent of the Contract Price of each Schedule will be paid after the Equipment have been installed, tested and operated or used for a period of 30 Days and the acceptance of the said Equipment has been made by EGAT against presentation of Acceptance Certificate to be issued by EGAT and submission of maintenance security by the Contractor. EGAT will list the minor pending claim(s), if any, and payment will be made by deducting such claimed amount.

However, if, through no fault of the Contractor or of the Equipment, such installation, test and operation or use of the Equipment are delayed beyond a period of six (6) Months after complete ex-works delivery; payment of this ten (10) per cent will be made as soon as possible but not later than the ninth (9<sup>th</sup>) Month after complete delivery and it shall be deemed as if acceptance of Equipment is made by EGAT at the end of the said sixth (6<sup>th</sup>) Month and the guarantee period shall start therefrom against submission of maintenance security by the Contractor.

In case there is some minor claim(s) or minor fault of the Contractor, the payment of this ten (10) per cent shall be made by deducting such claimed amount and the guarantee period of this part will start after such minor claim(s) has been settled by the Contractor and acceptance of which has been made by EGAT.

**b. Payment for Spare Parts**

One hundred (100) per cent will be paid after complete delivery against presentation of invoices, shipping documents and EGAT's letter of approval for shipment for foreign supply or the Contractor's statement or delivery order confirming the delivery of Equipment ex-works duly certified by EGAT's representative\* and EGAT's letter of approval for test report\*\* of the relevant Equipment and the acceptance has been made by EGAT. The guarantee period shall start from the day immediately following the date of the acceptance of the Spare Parts.

\*EGAT's representative means the authorized EGAT's Store personnel to verify the quantity of Equipment according to the packing list to be delivered to the site.

\*\*Test report means the report of tests specified in Article E-13. Inspection and Tests.

**c. Payment for Optional Items**

Payment for Equipment

One hundred (100) per cent will be paid after complete delivery with presentation of invoices, shipping documents and EGAT's letter of approval for shipment and the acceptance has been made by EGAT. The guarantee period shall start from the day immediately following the date of the acceptance of Equipment.

Payment for Mechanical Operation Life Test (if any)

One hundred (100) per cent of the cost of the Mechanical Operation Life Test will be paid after the test has been performed successfully and test report has been accepted by EGAT.

**d. Payment for Field Test Cost**

One hundred (100) per cent of Field Test Cost will be paid after the test has been performed successfully and the test report has been accepted by EGAT.

**e. Payment for Installation Supervisor**

Payment for the services of the installation supervisor will be made within thirty (30) Days after his release by EGAT. Payment will be made on the basis of actual working man-days at the quoted cost per man-day up to a maximum equal to the total man-days quoted. For man-days exceeding the quoted total man-days, no payment shall be made by EGAT unless the Contractor can claim for any delays in the progress of the work caused by EGAT. Any such additional man-days approved by EGAT shall be paid on the basis of the quoted man-day rate.

The number of quoted man-days shall include Sundays and shall cover a seven (7) day workweek, if required by the construction program. The working hours shall be forty-eight (48) hours per week, eight (8) hours per day, the working hours over 8 hours per day if requested by EGAT will be counted as overtime at 1½ times the regular hourly rate.

The amount to be paid for each Day for the services of the supervisor shall include for all salary, subsistence expense, insurance, compensations and personal expense of the supervisor, and all liabilities and responsibilities thereto. EGAT will pay for round-trip economy class air transportation for the installation supervisor between the Contractor's home office and Bangkok by the most expeditious and direct route on trip basis by draft after receipt of the Contractor's invoice supported with the used air ticket of such supervisor. The remission of immigration fees and taxes collectible by the Kingdom of Thailand shall not be paid by EGAT, as described in Article E-11. Fees and Duties.

*After each payment is made, the Contractor or beneficiary shall issue and submit the receipt to EGAT at e-mail : FFMS@egat.co.th within three (3) calendar days upon receipt of such payment. The details of receipt shall include but not be limited to the following:*

- *Company name and address*
- *The receipt date of payment*
- *Lists of Goods/Services the payment is made for*
- *Payment amount in numbers and in words*
- *Recipient signature*

#### **F-9. Liquidated Damages for Late Delivery of Equipment**

In the event of failure by the Contractor to make delivery of any Equipment within the time set forth in the Contract, plus any extension thereof authorized by EGAT as provided in the Contract, such failure shall be a default under the Contract for which the Contractor shall be liable for payment to EGAT as liquidated damages at the rate specified in Data Sheet.

Whenever any Equipment under any item is to be used together with other Equipment in other item as specified in Price Schedule as a complete set or unit, the Contractor shall make sure that they shall be shipped together as a complete set or unit. Failure on the part of the Contractor to comply with this requirement, the liquidated damages for late delivery of partial shipment shall be imposed on the Contractor for the whole amount of the Contract Price of such related items.

Notwithstanding, in case the Contractor fails to make delivery of minor part of any Equipment within the time set forth in the Contract and such late delivery does not have any

effect to the performance of the Equipment, the Contractor shall be liable for payment to EGAT as liquidated damages at the rate of one-tenth of one (0.10) per cent of the total price of the minor part of the Equipment not timely delivered for each Day of delay. The price of such delayed minor part of the Equipment shall be determined by EGAT. EGAT shall, at his own discretion, determine whether such late delivery Equipment is the minor part and has any effect to the performance of the Equipment or not.

The payment of such liquidated damages shall not relieve the Contractor of his obligations to complete the Work under the Contract.

In case any Equipment is defective or does not conform to the requirements or specifications of the Contract where replenishment or correction or replacement must be made by the Contractor as per Article E-29. Failure to Meet Requirements, it shall be deemed that such Equipment has not yet been delivered unless such Equipment has been replenished or corrected or replaced, as the case may be, and delivered to EGAT at the delivery point specified in the Contract.

Payment of liquidated damages is contingent exclusively upon late delivery; in no case shall EGAT be required to substantiate any claim for payment of liquidated damages with proof of loss and/or damages. The liquidated damages shall be calculated for each Day of delay until the Equipment is delivered to EGAT excluding a period of time from the actual delivery date at the delivery point set forth in the Contract until the issuance of notification of defect or short pack or out of specification made by EGAT to the Contractor. This sum is payable regardless of the actual loss and/or damages incurred.

The Contractor shall not be liable for liquidated damages in the event of delay caused by force majeure.

**F-10. Maintenance Guarantee**

- a. The Contractor shall guarantee the proper functioning of the Equipment for a period as specified in Data Sheet from the day immediately following the date of acceptance of Equipment by EGAT; provided, however, that should any malfunctioning and/or latent defect in Equipment under normal use and service be found during the said period, and such malfunctioning and/or defective portion be repaired or replaced as stipulated in (c) and (d) hereinafter, then the guarantee period for such portion shall be extended from the day immediately following the date of completion of such repair or replacement as follows:

<b>Time of Malfunctioning and/or Defect Found</b>	<b>Guarantee Period Extension</b>				
	<b>Equipment with 1-Year guarantee period</b>	<b>Equipment with 2-Year guarantee period</b>	<b>Equipment with 3-Year guarantee period</b>	<b>Equipment with 4-Year guarantee period</b>	<b>Equipment with 5-Year guarantee period</b>
<b>First Year</b>	For a new period of one (1) Year.	For a new period of two (2) Years.	For a new period of three (3) Years.	For a new period of four (4) Years.	For a new period of five (5) Years.
<b>Second Year</b>	n/a	For a new period of one (1) Year.	For a new period of two (2) Years.	For a new period of three (3) Years.	For a new period of four (4) Years.
<b>Third Year</b>	n/a	n/a	For a new period of one (1) Year.	For a new period of two (2) Years.	For a new period of three (3) Years.
<b>Fourth Year</b>	n/a	n/a	n/a	For a new period of one (1) Year.	For a new period of two (2) Years.
<b>Fifth Year</b>	n/a	n/a	n/a	n/a	For a new period of one (1) Year.

The premium for the maintenance guarantee shall be paid by the Contractor.

- b. On the expiration of the maintenance guarantee period and if the Equipment is functioning normally, the Contractor shall thereafter be released of all obligations and responsibilities under the Contract and the maintenance security deposited in accordance with Article F-7. Acceptance Certificate, will be released and returned to the Contractor.
- c. If during the guarantee period EGAT finds any malfunctioning and/or defect in the Equipment, EGAT shall inform without delay the Contractor thereof, stating in writing the nature of the malfunctioning and/or defect, and the Contractor shall promptly commence to repair and make good or replace such malfunctioning and/or defect at the expense of the Contractor, except that the cost of import duty and taxes,

inland transportation and installation of the replacement parts for foreign supply Equipment, and the cost of inland transportation and the installation of the replacement parts for local supply Equipment will be borne by EGAT.

For Equipment specified in Data Sheet, in case EGAT, at its sole discretion, requires the Contractor to replace any defected Equipment, the Contractor shall replace the Equipment with the whole new set at its own costs and expenses including the cost of all re-export charges (if any), import duty and taxes, landing charges, rents and handling charges (ocean freight), storage charges (air freight), truck hire, labour charges, service charges for customs clearance, inland transportation and installation of the Equipment.

- d. If, after the repair or replacement performed in accordance with this Article, such Equipment continues to show malfunctioning and/or defect, EGAT may, at its option, demand further repair or replacement, and reserve the right to claim damages, if applicable, arising therefrom.
- e. If the Contractor fails to take action for starting up the necessary works for repair or replacement within fourteen (14) Days after receipt of EGAT's written notice of defect, the defect will be corrected by EGAT or any third party selected by EGAT at EGAT's discretion, and the cost of the corrections shall be on the responsibility and account of the Contractor.

In the event of an emergency where in the judgement of EGAT the delay resulting from giving formal notice would cause serious loss or damage which could be prevented by immediate action, defects may be corrected by EGAT or a third party chosen by EGAT without giving prior notice to the Contractor, and the cost of the corrections shall be paid by the Contractor. In the event such action is taken by EGAT, the Contractor will be notified promptly and shall assist wherever possible in making the necessary corrections.

#### **F-11. Drawings and Documents to be Furnished by Contractor**

EGAT reserves the right to require the Contractor to submit the drawings and documents listed in the tables attached at the end of this Section by the designated dates either by registered airmail for foreign mail and registered mail for local mail and/or by electronic files uploaded via document management system. However, cover letters shall be submitted in hard copy to EGAT.

After the requirement under this Article has been fulfilled by the Contractor, a Drawing and Document Acceptance Certificate will be issued by EGAT to certify the receipt of all required drawings and documents:

a. Drawings

- (1) Drawing Title and Sizes. The title of Contractor's drawing shall also include the followings :

ELECTRICITY GENERATING AUTHORITY OF THAILAND

EGAT's Contract No. \_\_\_\_\_

Item No. \_\_\_\_\_

Subs. Name \_\_\_\_\_

The sizes of the drawings except otherwise specified in the Specification shall be as follows :

<u>Size Designation</u>	<u>Dimensions in MM</u>	<u>Dimensions in Inches</u>
A0	841 x 1,189	(33.11 x 46.81)
A1	594 x 841	(23.39 x 33.11)
A2	420 x 594	(16.54 x 23.39)
A3	297 x 420	(11.69 x 16.54)
A4	210 x 297	( 8.27 x 11.69)

- (2) Reference Drawings and Catalogues. General drawings showing principal dimensions and weights of Equipment, including controlling dimensions which affect space and handling requirements.

- (3) Drawings and Data for Approval. The Contractor shall submit for approval checked detail assembly drawings including firm dimensions, foundation details and setting diagrams, physical size and weights of all principal parts, complete operating characteristics and ratings of Equipment, connection and schematic wiring diagrams, descriptive information and any other information sufficient to demonstrate fully that the Equipment to be furnished will conform to the requirements and intent of these Contract Documents.

Schematic diagrams shall indicate the operation and function of all electrical Equipment, accompanied, where necessary, with explanatory notes. Wiring diagrams shall show the external connection required, sufficient for EGAT to complete interconnection cable diagrams.

One print each of the drawings submitted for approval will be returned to the Contractor by EGAT or its authorized representative within thirty (30) Days after receipt at EGAT's office, marked either "Approved",

"Approved Except as Noted", or "Returned for Correction"/"Not Reviewed". The notations "Approved" or "Approved Except as Noted" will authorize the Contractor to proceed with the manufacture of the Equipment covered by such drawing, subject to the correction, if any, indicated thereon. When prints of drawings have been "Returned for Correction"/"Not Reviewed"., the Contractor shall make the necessary revisions on the drawings and shall within thirty (30) Days resubmit drawings for approval in the same manner as before.

Any manufacturing done before approval of the drawings will be at the Contractor's risk. EGAT shall have the right to require the Contractor to make any changes in the design which may be necessary, in the opinion of EGAT, to make the Equipment conform to the requirements and intent of these Contract Documents without additional cost to EGAT. Approval of the Contractor's drawings shall not be held to relieve the Contractor of any part of his obligation to meet all of the requirements of these Contract Documents or of the responsibility for the correctness of his drawings.

- (4) Reproducibles of all final approved drawings shall be made on mylar films.
- b. Report of Shop Test. The Contractor shall furnish certified copies of reports of all tests required of the manufacturer to show compliance with the applicable standards and specifications. The cost of all tests and reports shall be borne by the Contractor.
- c. Instruction Manuals. The Contractor shall furnish complete set of instruction manuals and all final approved drawings (if any) for erection, operation, maintenance and repair of the Equipment, and for identification of parts. The instruction manuals shall be combined, assembled and bound in binders. Each binder cover shall be stamped with proper identification indicating name of Equipment, manufacturer's name and address, EGAT's Contract number, manufacturer's reference, etc.

Prior to the assembly and submittal of the instruction manuals, a proof of the cover lettering and the table of contents shall be submitted in sufficient time for EGAT's acceptance without delaying submittal of the finished manuals.

The CD-ROM (Compact Disc-Read Only Memory) of final drawings, final documents, test report and instruction manual, if required, shall conform to the applicable International Standard Organization 9660 (ISO 9660) and have capacity of approximately 700 Mbytes.

The data in CD-ROM shall be created by the following software :

### Drawing

The Contractor shall submit all drawings created by CAD software as follows:

1. MICROSTATION software Version SE or
2. AUTOCAD software Version 2000

Any necessary information supporting the completion of reading files (such as special font etc.) shall be included in CD-ROM.

### Documents

The Contractor shall submit all documents in Adobe Portable Document Format File (PDF format) and also Program of Acrobat Reader in order to read the file completely in CD-ROM.

### Drawing/Document List

The Contractor shall submit the drawings/documents listing information in work sheets file provided by EGAT in CD-ROM in Microsoft Excel file format.

Drawing list of design drawings, as built drawings, manufacturing drawings shall also be submitted together with the drawings in the CD-ROM.

## **F-12. Maintenance Security**

The Contractor shall provide to EGAT prior to the issuance of the acceptance certificate and as a condition for the release of the payment of the last instalment as specified in Article F-8. Payment, maintenance security(ies) in the amount of ten (10) per cent, round up to the nearest whole number, of the total Contract Price or ten (10) per cent, round up to the nearest whole number, of each schedule, excluding the cost of installation supervisor and cost of test(s), guaranteeing the Contractor's performance of the provision of Article F-10. Maintenance Guarantee. The Contractor shall oblige himself to attend to and replace, during the period of maintenance, all malfunctioning parts and for repair of all defects noted in the Work and communicated to the Contractor in writing by EGAT. In case of extended guarantee of the repaired or replaced Equipment, the Contractor may request for return of the original maintenance security and submit a new maintenance security in the amount of ten (10) per cent, round up to the nearest whole number, of the Contract Price of Equipment under the extended guarantee.

The maintenance security shall be in the form of a cash deposit, or a cashier cheque issued by a local bank, or a bank guarantee or letter of guarantee issued only by a local bank or an acceptable financial institution in Thailand, or by a foreign bank counter-

guaranteed by a local bank, and made payable to EGAT in the same currency as that of the Contract. In case of a cash deposit or a cashier cheque, only Thai baht portion of the Contract Price can be made. EGAT may at its absolute discretion refuse to approve any maintenance security offered or may at any time, upon application by the Contractor, approve of the substitution for any maintenance security held under this Article by other maintenance security on such terms and conditions as may be approved by EGAT.

The conditions of guarantor's obligations in the maintenance security shall include, inter alia; the following :

1. The guarantor shall unconditionally guarantee, as primary obligor and not as surety merely, payment of any obligations, damages, liquidated damages, performance penalties, or expenses for which the Contractor may become liable to EGAT.
2. No extension of time, change in, addition to, or other modification of the terms of the Contract or Work to be performed thereunder, or of the Specifications or other Contract Documents shall in anyway release the guarantor from any liability under the maintenance security, and the guarantor shall thereby waive notice of any such extension of time, change, addition or modification.
3. The maintenance security shall be valid and remain in full effect from the date of acceptance of Work until all obligations on the part of the Contractor under the Contract have been fulfilled.

Unless and until an official receipt is issued in respect to a maintenance security deposit, EGAT will not recognize or accept any such deposit as fulfilling the requirements of this Article. Failure to deposit a maintenance security at the time specified above in this Article or such extended time as may be approved by EGAT shall be a breach of this Contract and EGAT may, at its discretion, retain the payment of the last instalment of the total Contract Price.

If any maintenance security furnished under this Article shall become unacceptable to EGAT, or if any guarantor shall fail to furnish reports as to guarantor's financial condition from time to time, as requested by EGAT, the Contractor shall promptly furnish such additional or alternative maintenance security as may be necessary to satisfy the Contract requirements for a maintenance security.

In the event of any default or breach of this Contract on the part of the Contractor, EGAT may convert into money any maintenance security which does not consist of money, and the proceeds shall be deemed to be a cash deposit under this Article. EGAT shall not be liable for any cost, expenses and/or loss resulting from the conversion of any maintenance security deposit into money as herein provided. The Contractor shall bear the cost of the maintenance security.

The maintenance security, in case of a bank guarantee, or letter of guarantee, shall be in conformity with the following specimen.

## SPECIMEN OF MAINTENANCE GUARANTEE

To :

Date :

Electricity Generating Authority of Thailand  
Bangkruai, Nonthaburi 11130  
Thailand

Re : Maintenance Security for Contract  
No. EGAT \_\_\_\_\_

Gentlemen :

In accordance with the provision of the Contract for \_\_\_\_\_ No. EGAT \_\_\_\_\_ dated \_\_\_\_\_ (hereinafter referred to as the Contract), the contents of which have been noted by us that Messrs. \_\_\_\_\_ (hereinafter referred to as the Contractor) has to deposit with Electricity Generating Authority of Thailand, (hereinafter referred to as EGAT) a Maintenance Security to guarantee the proper functioning of the \_\_\_\_\_ of the Contract as specified in Article F-10. Maintenance Guarantee in the amount of \_\_\_\_\_ (in words : \_\_\_\_\_) which is ten (10) per cent, round up to the nearest whole number, of the total Contract Price or ten (10) per cent, round up to the nearest whole number, of each schedule of the said Work, excluding the cost of installation supervisor and cost of test(s), we, the \_\_\_\_\_ as instructed by the Contractor, agree unconditionally to irrevocably guarantee as primary Obligor, the payment to EGAT at its first demand, without whatsoever right of objection on our part and without its first claim with the Contractor giving EGAT the right of claim for penalty, damages, liquidated damages or any expenses for which the Contractor may become liable to EGAT under the Contract.

We further agree that no extension of time, change in, addition to or other modification of terms of the Contract or work to be performed thereunder, or of the Specifications or other Contract Documents, which may be made between EGAT and the Contractor, shall in any way release us from any liability under the Maintenance Security, and we shall thereby waive notice of any such extension of time, change, addition or modification.

This Maintenance Security shall be valid and remain in full effect for a period of \_\_\_\_\_ (...) Year(s) from the day immediately following the date of the acceptance of Equipment. If necessary, this Maintenance Security shall be extended as specified in Article F-10. Maintenance Guarantee.

Yours very truly,

\_\_\_\_\_  
Authorized Signature

**Drawings and Documents to be Furnished by the Contractor**  
**(For Control and Protection Equipment)**

The Contractor shall submit by registered mail and/or by electronic files uploaded via document management system with the drawings and other documents listed below by the designated deadlines.

Should EGAT require the Contractor to submit the drawings and documents in electronic files via EGAT's document management system, the Contractor is also required to submit the drawings and documents in Print and CD-ROM at the number of copies listed in the parenthesis below.

Drawings/Documents	No. of copies		Deadline and Remarks
	P	CD-ROM	
Manufacturing and Delivery Schedule	1 (-)	- (-)	Within 60 Days after confirmation of Letter of Award of Contract
Quality Assurance Program ( If requested by EGAT )	1 (-)	- (-)	Within 60 Days after confirmation of Letter of Award of Contract
Drawings or Documents "RELAY AND EQUIPMENT INSTRUCTION MANUAL"	1 (-)	- (-)	Within 90 Days after confirmation of Letter of Award of Contract
Drawings or Documents "FOR APPROVAL"	1 (1)	- (-)	Within 90 Days after confirmation of Letter of Award of Contract
Drawings or Documents "FOR REAPPROVAL"	1 (1)	- (-)	Within 30 Days after receipt of returned approval drawings for correction
Drawings "DRAFT-FINAL DRAWING"	1 (1)	- (-)	Within 30 Days for P and 60 Days for CD-ROM after receipt of returned approved drawings
Drawings and Documents "FINAL DRAWING or FINAL DOCUMENT"	1 (1)	1 (1)	Within 20 Days after Equipment delivery
Test Procedure (Factory Test)	1 (-)	- (-)	Within 90 Days after confirmation of Letter of Award of Contract
Test Schedule (Factory Test)	1 (-)	- (-)	Not less than 60 Days before testing for foreign supply Not less than 30 Days before testing for local supply
Test Report (Factory Test)	1 (-)	- (-)	Upon completion of tests
Instruction Manuals	- (-)	3(3)	30 Days before first shipment/delivery

**Note :** P = Print Drawing or Document  
CD-ROM = Compact Disc-Read Only Memory with capacity of approximate 700 Mbytes conforming to ISO 9660

**Drawings and Documents to be Furnished by the Contractor**  
**(For All Equipment except Control and Protection Equipment)**

The Contractor shall submit by registered mail and/or by electronic files uploaded via document management system with the drawings and other documents listed below by the designated deadlines.

Should EGAT require the Contractor to submit the drawings and documents in electronic files via EGAT's document management system, the Contractor is also required to submit the drawings and documents in Print and CD-ROM at the number of copies listed in the parenthesis below.

Drawings/Documents	No. of copies		Deadline and Remarks
	P	CD-ROM	
Manufacturing and Delivery Schedule	1 (-)	- (-)	Within 60 Days after confirmation of Letter of Award of Contract
Quality Assurance Program ( If requested by EGAT )	1 (-)	- (-)	Within 60 Days after confirmation of Letter of Award of Contract
Drawings or Documents "FOR REFERENCE"	4 (2)	- (-)	Within 90 Days after confirmation of Letter of Award of Contract
Drawings or Documents "FOR APPROVAL"	4 (-)	- (-)	Within 60 Days for foundation, steel supporting structure (if any) and within 90 Days for others after confirmation of Letter of Award of Contract
Drawings or Documents "FOR REAPPROVAL"	4 (-)	- (-)	Within 30 Days after receipt of returned approval drawings for correction
Drawings and Documents "FINAL DRAWING or FINAL DOCUMENT"	4 (2) *4 (-)	- (-)	Within 30 Days after receipt of approved drawings
Final Design Data	4 (-)	- (-)	Within 150 Days after confirmation of Letter of Award of Contract
Test Procedure (Factory Test)	1 (-)	- (-)	Within 150 Days after confirmation of Letter of Award of Contract
Test Schedule (Factory Test)	1 (-)	- (-)	Not less than 60 Days before testing for foreign supply Not less than 30 Days before testing for local supply
Test Report (Factory Test)	1 (-)	- (-)	Upon completion of tests
Installation Instruction	9 (7)	5 (5)	60 Days before first shipment/delivery
Instruction Manuals	9 (7)	5 (5)	Before shipment/delivery

**Note :** P = Print Drawing or Document  
CD-ROM = Compact Disc-Read Only Memory with capacity of approximate 700 Mbytes conforming to ISO 9660

\*For Transmission Line Insulator, Hardware Assemblies and Line Accessories, Transmission Line Steel Tower, HTLS Transmission Line Conductor and Invar Transmission Line Conductor.

**DRAFT**

**SECTION G**  
**RATINGS AND FEATURES**

## **G. RATINGS AND FEATURES**

### **G -1. Ratings and Features**

The following Ratings and Features sheets are attached hereto and made a part of the Contract Documents:

<u>RF No.</u>	<u>Description</u>	<u>Page</u>
PD9W1A	Coupling Capacitor Voltage Transformer	G2
PD9W1B	Coupling Capacitor Voltage Transformer	G3-G4
VT901A	Inductive Voltage Transformer	G5
CT9AFAI	Current Transformer	G6
CT9AFDI	Current Transformer	G7

DRAFT

**Coupling Capacitor Voltage Transformer  
Specification No. 761**



**Substation Electrical  
Equipment Engineering Department**

<b>Ratings and Features</b>	<b>Designed : via ECM system</b>	<b>Validated : via ECM system</b>	<b>Revision 0</b>	<b>Page 1/1</b>
<b>RF No. PD9W1A</b>	<b>Verified : via ECM system</b>	<b>Approved : via ECM system</b>	<b>Dated : 23/01/2026</b>	

a. Type	Outdoor, Oil Filled	
b. Rated Frequency	50	Hz
c. Nominal System Voltage	525	kV
d. Highest Voltage for Equipment	550	kV
e. Rated Insulation Level		
- Power Frequency Withstand Voltage, rms	680	kV
- Lightning Impulse Withstand Voltage, peak	1550	kV
- Switching Impulse Withstand Voltage, peak	1175	kV
f. Creepage Distance of Insulator	≥ 13750*	mm
g. Rated Primary Voltage	525/√3	kV
h. Connection of Primary Winding	Line to Ground	
i. Transformation Ratio	2526/4375 & 2526/4375 & 2526/4375:1	
j. Rated Secondary Voltage		
- No.1 Secondary Winding	120 / (120/√3)	V
- No.2 Secondary Winding	120 / (120/√3)	V
- No.3 Secondary Winding	120 / (120/√3)	V
k. Rated Output		
- No.1 Secondary Winding	0 - 30	VA
- No.2 Secondary Winding	0 - 30	VA
- No.3 Secondary Winding	0 - 30	VA
- Simultaneous	0 - 90	VA
l. Rated Accuracy Class		
- No.1 Secondary Winding	3P	
- No.2 Secondary Winding	3P	
- No.3 Secondary Winding	3P	
m. High Voltage Capacitance (C1)	≥ 4000	pF
n. Carrier Accessories	[x] With	[ ] Without
o. Carrier Drain Coil		
- Impulse Withstand Voltage	10	kV
- Frequency Range	70-450	kHz
- Max. Insertion Loss at Specified Frequency Range	≤ 0.5	dB
- Max. Voltage Drop at 50 Hz	≤ 30	V
p. Rated Voltage Factor	1.5 for 30 s	
q. Transient Response Class	3PT1	
r. Line Terminals	Vertical Take-off Terminal Pad, 6-Hole NEMA Pad, 2x3 Bolt Hole Pattern	
s. Mounting	Pedestal	
t. Applicable Standard	IEC 61869-1, 5	

Note : \* Special Creepage Distance ; Base on 25 mm/kV<sub>max.L-L</sub>

**Coupling Capacitor Voltage Transformer  
Specification No. 761**



**Substation Electrical  
Equipment Engineering Department**

<b>Ratings and Features</b>	<b>Designed : via ECM system</b>	<b>Validated : via ECM system</b>	<b>Revision 0</b>	<b>Page 1/2</b>
<b>RF No. PD9W1B</b>	<b>Verified : via ECM system</b>	<b>Approved : via ECM system</b>	<b>Dated : 13/03/2026</b>	

a. Type	Outdoor, Oil Filled	
b. Rated Frequency	50	Hz
c. Nominal System Voltage	525	kV
d. Highest Voltage for Equipment	550	kV
e. Rated Insulation Level		
- Power Frequency Withstand Voltage, rms	680	kV
- Lightning Impulse Withstand Voltage, peak	1550	kV
- Switching Impulse Withstand Voltage, peak	1175	kV
f. Creepage Distance of Insulator	≥ 13750*	mm
g. Rated Primary Voltage	525/√3	kV
h. Connection of Primary Winding	Line to Ground	
i. Transformation Ratio	2526/4375 & 2526/4375 & 2526/4375 & 2526/4375:1	
j. Rated Secondary Voltage		
- No.1 Secondary Winding	120 / (120/√3)	V
- No.2 Secondary Winding	120 / (120/√3)	V
- No.3 Secondary Winding	120 / (120/√3)	V
- No.4 Secondary Winding	120 / (120/√3)	V
k. Rated Output		
- No.1 Secondary Winding	0 - 30	VA
- No.2 Secondary Winding	0 - 30	VA
- No.3 Secondary Winding	0 - 30	VA
- No.4 Secondary Winding	0 - 30	VA
- Simultaneous	0 - 120	VA
l. Rated Accuracy Class		
- No.1 Secondary Winding	3P	
- No.2 Secondary Winding	3P	
- No.3 Secondary Winding	0.2	
- No.4 Secondary Winding	0.2	
m. High Voltage Capacitance (C1)	≥ 4000	pF
n. Carrier Accessories	[x] With	[ ] Without
o. Carrier Drain Coil		
- Impulse Withstand Voltage	10	kV
- Frequency Range	70-450	kHz
- Max. Insertion Loss at Specified Frequency Range	≤ 0.5	dB
- Max. Voltage Drop at 50 Hz	≤ 30	V
p. Rated Voltage Factor	1.5 for 30 s	
q. Transient Response Class	3PT1	
r. Line Terminals	Vertical Take-off Terminal Pad, 6-Hole NEMA Pad, 2x3 Bolt Hole Pattern	

**Coupling Capacitor Voltage Transformer  
Specification No. 761**



**Substation Electrical  
Equipment Engineering Department**

<b>Ratings and Features</b>	<b>Designed : via ECM system</b>	<b>Validated : via ECM system</b>	<b>Revision 0</b>	<b>Page 2/2</b>
<b>RF No. PD9W1B</b>	<b>Verified : via ECM system</b>	<b>Approved : via ECM system</b>	<b>Dated : 13/03/2026</b>	

s. Mounting

Pedestal

t. Applicable Standard

IEC 61869-1, 5

Note : \* Special Creepage Distance ; Base on 25 mm/kV<sub>max.L-L</sub>

**DRAFT**

**Inductive Voltage Transformer  
Specification No. 762**



**Substation Electrical  
Equipment Engineering Department**

<b>Ratings and Features</b>	<b>Designed : via ECM system</b>	<b>Validated : via ECM system</b>	<b>Revision 0</b>	<b>Page 1/1</b>
<b>RF No. VT901A</b>	<b>Verified : via ECM system</b>	<b>Approved : via ECM system</b>	<b>Dated : 13/03/2026</b>	

a. Type	Outdoor, Oil Filled	
b. Rated Frequency	50	Hz
c. Nominal System Voltage	525	kV
d. Highest Voltage for Equipment	550	kV
e. Rated Insulation Level		
- Power Frequency Withstand Voltage, rms	680	kV
- Lightning Impulse Withstand Voltage, peak	1550	kV
- Switching Impulse Withstand Voltage, peak	1175	kV
f. Creepage Distance of Insulator	≥ 13750*	mm
g. Rated Primary Voltage	525/√3	kV
h. Connection of Primary Winding	Line to Ground	
i. Transformation Ratio		
- No.1 Secondary Winding	2526/4375:1	
- No.2 Secondary Winding	2526/4375:1	
- No.3 Residual Voltage Winding	2756:1	
j. Rated Secondary Voltage Rating		
- No.1 Secondary Winding	120 / (120/√3)	V
- No.2 Secondary Winding	120 / (120/√3)	V
- No.3 Residual Voltage Winding	110	V
k. Rated Output for Secondary Winding No.1 and 2		
- No.1 Secondary Winding	0 - 30	VA
- No.2 Secondary Winding	0 - 30	VA
- Simultaneous	0 - 60	VA
l. Rated Accuracy Class		
- No.1 Secondary Winding	0.2 & 3P	
- No.2 Secondary Winding	0.2 & 3P	
m. Rated Output for Residual Voltage Winding		
- No.3 Residual Voltage Winding	for damping resistor 60 ohm	
- Thermal Limiting Output	≥ 1050	VA
n. Polarity	Subtractive	
o. Rated Voltage Factor	1.9 for 8 hrs	
p. Line Terminal	Vertical Take-off Terminal Pad, 6-Hole NEMA Pad, 2x3 Bolt Hole Pattern	
q. Mounting	Pedestal	
r. Applicable Standard	IEC 61869-1, 3	

Note : \* Special Creepage Distance ; Base on 25 mm/kV<sub>max.L-L</sub>

\*\* In case of the test procedure/condition of Temperature Rise Test and Test for Accuracy (Type Test) did not conform to EGAT requirements. These tests shall be performed on one unit of Inductive Voltage Transformer being supplied for each rating after receipt of Award of Contract.

**Current Transformer  
Specification No. 751**



**Substation Electrical  
Equipment Engineering Department**

<b>Ratings and Features</b>	<b>Designed : via ECM system</b>	<b>Validated : via ECM system</b>	<b>Revision 0</b>	<b>Page 1/1</b>
<b>RF No. CT9AFAI</b>	<b>Verified : via ECM system</b>	<b>Approved : via ECM system</b>	<b>Dated : 2/12/2025</b>	

a. Type	Outdoor, Oil Filled		
b. Rated Frequency	50	Hz	
c. Highest Voltage for Equipment	550	kV	
d. Rated Insulation Level			
- Power Frequency Withstand Voltage, rms	680	kV	
- Lightning Impulse Withstand Voltage, peak	1550	kV	
e. Creepage Distance of Insulator	≥ 13750*	mm	
f. Rated Primary Current	4000	A	
g. Rated Secondary Current	1	A	
h. Current Ratio			
- Core No.1	2000-3000-4000/1		
- Core No.2	2000-3000-4000/1		
- Core No.3	2000-3000-4000/1		
- Core No.4	2000-3000-4000/1		
- Core No.5	2000-3000-4000/1		
- Core No.6	2000-3000-4000/1		
i. Accuracy Class			
- Core No.1	5P20, 50-75-100 VA		
- Core No.2	5P20, 50-75-100 VA		
- Core No.3	5P20, 50-75-100 VA		
- Core No.4	5P20, 50-75-100 VA		
- Core No.5	5P20, 50-75-100 VA		
- Core No.6	5P20, 50-75-100 VA		
j. Rated Continuous Thermal Current	120%		
k. Short Time Current Rating			
- Thermal for 1 second	50	kA rms	
- Dynamic	125	kA peak	
l. Application Requirement for TPY core			
- Rated Primary Time Constant ( $T_p$ )	-	ms	
- Duty Cycle for C-O-C-O cycle (C-t'-O-t <sub>ff</sub> -C-t''-O)	-	ms	
- Time to accuracy limit ( $t'_{al}, t''_{al}$ )	-	ms	
m. Polarity	Subtractive		
n. Line Terminals	Horizontal Take-off Terminal Pad 6-Hole NEMA Pad 2x3 Bolt Hole Pattern		
o. Mounting	Pedestal		
p. Applicable Standard	IEC 61869-1, 2		

Note : \* Special Creepage Distance ; Base on 25 mm/kV<sub>max.L-L</sub>

\*\* Routine accuracy test shall be performed for every secondary tap by using rated output values on item i.

**Current Transformer  
Specification No. 751**



**Substation Electrical  
Equipment Engineering Department**

<b>Ratings and Features</b>	<b>Designed : via ECM system</b>	<b>Validated : via ECM system</b>	<b>Revision 0</b>	<b>Page 1/1</b>
<b>RF No. CT9AFDI</b>	<b>Verified : via ECM system</b>	<b>Approved : via ECM system</b>	<b>Dated : 2/12/2025</b>	

a. Type	Outdoor, Oil Filled		
b. Rated Frequency	50	Hz	
c. Highest Voltage for Equipment	550	kV	
d. Rated Insulation Level			
- Power Frequency Withstand Voltage, rms	680	kV	
- Lightning Impulse Withstand Voltage, peak	1550	kV	
e. Creepage Distance of Insulator	≥ 13750*	mm	
f. Rated Primary Current	4000	A	
g. Rated Secondary Current	1	A	
h. Current Ratio			
- Core No.1	2000-3000-4000/1		
- Core No.2	2000-3000-4000/1		
- Core No.3	2000-3000-4000/1		
- Core No.4	2000-3000-4000/1		
- Core No.5	2000-3000-4000/1		
- Core No.6	2000-3000-4000/1		
i. Accuracy Class			
- Core No.1	5P20, 50-75-100 VA		
- Core No.2	5P20, 50-75-100 VA		
- Core No.3	5P20, 50-75-100 VA		
- Core No.4	5P20, 50-75-100 VA		
- Core No.5	TPY, 5-7.5-10 Ω		
- Core No.6	TPY, 5-7.5-10 Ω		
j. Rated Continuous Thermal Current	120%		
k. Short Time Current Rating			
- Thermal for 1 second	50	kA rms	
- Dynamic	125	kA peak	
l. Application Requirement for TPY core			
- Rated Primary Time Constant ( $T_p$ )	120	ms	
- Duty Cycle for C-O-C-O cycle (C-t'-O-t <sub>ff</sub> -C-t''-O)	C-100ms-O-400ms-C-100ms-O		
- Time to accuracy limit ( $t'_{al}, t''_{al}$ )	60, 60	ms	
m. Polarity	Subtractive		
n. Line Terminals	Horizontal Take-off Terminal Pad 6-Hole NEMA Pad 2x3 Bolt Hole Pattern		
o. Mounting	Pedestal		
p. Applicable Standard	IEC 61869-1, 2		

Note : \* Special Creepage Distance ; Base on 25 mm/kV<sub>max.L-L</sub>

\*\* Routine accuracy test shall be performed for every secondary tap by using rated output values on item i.

**DRAFT**

**SECTION I  
SPECIFICATIONS**

## I. SPECIFICATIONS

### I-1. Specifications

The following specifications are attached hereto and made a part of the Contract Documents :

<u>Specification No.</u>	<u>Description</u>	<u>Page</u>
751 (July 2025)	Oil-filled Current Transformer	751.1 – 751.9
761 (Aug. 2025)	Oil-filled Coupling Capacitor Voltage Transformer	761.1 – 761.8
762 (Aug. 2025)	Oil-filled Inductive Voltage Transformer	762.1 – 762.7

## Specification No 751

### Oil-filled Current Transformer

**751-1 General.** This specification covers the general requirements for design, manufacture, test and supply of current transformer (CT).

The specific ratings, characteristics and the special requirements and features of the equipment not covered herein are given in the accompanying Ratings and Features sheet (if any).

**751-2 Materials and Workmanship.** All materials shall be new and shall be the best available for the purposes used, considering strength, ductility, durability and suitability for the intended services and best engineering practice. Workmanship shall be of the highest grade and in accordance with the best modern standard practice.

**751-3 Service Conditions.** All materials shall be suitable for installation and use at an altitude of 1000 m or less in a tropical climate with a maximum ambient temperature of 45°C and 100% relative humidity for outdoor equipment (or a maximum ambient temperature of 40°C and 90% relative humidity for indoor equipment) without corrosion, deterioration or degradation of performance characteristics.

**751-4 Codes and Standards.** All equipment, materials, devices, fabrication and testing shall conform to the codes, specifications and standards listed below and all applicable codes, specifications and standard referred therein.

ANSI	American National Standards Institute
ASME	American Society of Mechanical Engineers
ASTM	American Society for Testing and Materials
AWS	American Welding Society
IEC	International Electrotechnical Commission
IEEE	The Institute of Electrical and Electronics Engineers
NEMA	National Electrical Manufacturers Association

เอกสารไม่ควบคุม

รับรองสำเนาโดย มหอ.ร. กสส.-ร.อวส.

ก่อนนำไปใช้งาน

ต้องตรวจสอบ .Revision ล่าสุด

ฝ่ายวิศวกรรมระบบส่ง กฟผ.

31 มีนาคม 2569

All threaded parts requiring external connection shall have metric screw and pipe threads. All internal parts may have threads in accordance with the established specification in the country of manufacturer.

It is the intent that all equipment, materials, devices, fabrication and testing shall conform to the application codes, specifications and standards even though they are not specifically noted herein. Equivalent codes, specifications and standards established and approved in the country of equipment or material manufacture may be used subject to EGAT's approval. If this election is made, the Bidder shall

so state and include in his bid the governing codes, specifications, and standards proposed together with an itemized list of specific deviations from the requirements of codes, specifications and standards referred herein.

The latest issue of all codes, specifications and standards shall govern.

The most stringent requirement, in the event of code, specification or standard conflict, shall govern. This specification shall govern in the event of discrepancies between it and applicable codes, specifications and standards.

## 751-5 Design and Construction

**751-5.1 Type and Construction.** The type and ratings of equipment shall be in accordance with the accompanying Ratings and Features sheet.

The expansion system for changing of oil volume to variation in oil transformer shall be metallic bellow, other oil expansion systems are not acceptable.

The current transformer with core molded or encapsulated in epoxy resin or located in porcelain housing is not acceptable.

The both ends of porcelain housing shall be cemented to the transformer base and head flanges. The porcelain which is fixed by clamps is not acceptable.

For 33 kV current transformer and below, the inverted (top core) type current transformer is not acceptable.

**751-5.2 Terminal Pad.** Each equipment terminal for connecting to the line or other equipment shall be equipped with a suitable terminal pad unless otherwise specified. The terminal pad shall be provided with 14.3 mm (9/16 in) diameter holes with 45 mm (1-3/4 in) spacing between the centers of each hole in accordance with the NEMA Standards CC1, number of holes specified in Ratings and Features sheet.

The terminal pad shall be of high conductivity bronze, copper or aluminum alloy and, unless it is made of aluminum alloy, shall be plated with electro-tin to a thickness of not less than 0.0127 mm (0.0005 in).

**751-5.3 Porcelain Housings.** Porcelain housings shall have adequate mechanical and electrical strength. The color of porcelain shall be of chocolate brown. Porcelain housings shall be wet process, homogeneous and free from cavities or other flaws. The glazing shall be uniform in color and free from blisters, burns and other defects.

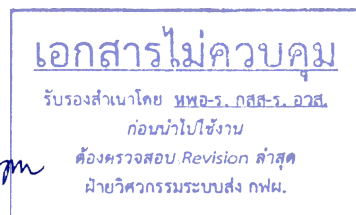

31 มีนาคม 2569

*Sotajid Hirinon*

**751-5.4 Ground Terminal Connectors.** Two (2) units of ground terminal connectors shall be of the clamp type suitable for No 4/0 AWG copper stranded conductor. Terminal connector shall be made of high conductivity material and shall be completed with corrosion resistance bolts, nuts and lock washers.

**751-5.5 Secondary Terminal Box.** Degree of protection for secondary terminal box shall be at least IP54.

**a. For 69 kV Current Transformer and above.** The hole shall be provided at the bottom of secondary terminal box suitable for 2 in (outside diameter of 62 mm) rigid steel conduit of the following quantity:

Secondary winding	- 5 or 6 cores	:	3 holes
	- 3 or 4 cores	:	2 holes
	- 1 or 2 cores	:	1 hole

Bottom hole(s) shall be knock-out type or furnished with suitable cover to prevent internal devices of secondary terminal box during transportation and storage.

**b. For 33 kV Current Transformer and below.** Flexible sealing cable gland shall be provided at the bottom of secondary terminal box suitable for cable of 26 mm outside diameter of the following quantity:

Relaying class	:	2 sets of cable
Metering class	:	1 set of cable

**751-5.6 Terminations.** All current transformer secondary winding terminals which connected to terminals on terminal blocks located in the junction boxes, shall have the size suitable for termination of 6 mm<sup>2</sup> cable and shall be short-circuit, ring tongue crimp type terminal for each maximum ratio of each core at the terminal blocks in both the secondary terminal box and junction box.

**751-5.7 Transient Performance.** The design of secondary cores of 500 kV Current Transformer for using with transmission line protective relay systems shall be satisfactory for the conditions specified in the Ratings and Features sheet including the specified circuit breaker reclosing operation. They shall permit one cycle of accurate, undistorted output prior to any saturation for a full asymmetrical short circuit condition.

The cores used for transmission line protection shall be furnished with gaps to reduce the remanence, and designed with a low enough secondary time constant such that the maximum instantaneous error during current flow after circuit breaker reclosing is less than the value specified in the Ratings and Features sheet.

**751-5.8 Protective Devices.** All current transformers, rated 69 kV and above, shall be equipped with a primary bypass protective device or surge arrester for protection of the winding from high voltage surges. In case of current transformers rated 69 kV and above, supplied without primary bypass protective device or surge arrester, calculation data of high voltage surge withstanding for primary winding shall be submitted to EGAT for approval.

**751-5.9 Supporting Structures.** Supporting structures, if specified in the Price Schedule, shall be hot-dip galvanized after fabrication in accordance with ASTM A123, A153 and A53. All necessary galvanized bolts, nuts and washers to complete the erection shall be furnished including embedded anchor bolts for securing the supporting structures to the concrete foundation.

The galvanizing coating shall meet the values as shown in the following table.

**Galvanizing Coating Weight**

Description	Thickness	Coating Weight (g/m <sup>2</sup> )	
		Average Value	Minimum Value
Shaped steel and steel plate	6 mm and over under 6 mm	more than 702 more than 610	more than 610 more than 550
Steel pipe	-	more than 550	more than 490
Bolts, nuts	-	more than 381	more than 305
Washers, filters	5 mm and over under 5 mm	more than 381 more than 305	more than 305 more than 259

Finished materials shall be dipped into the solution of dichromate after galvanizing for white rust protection.

**Marking.** all individual pieces shall be marked with the correct designations shown on the approved shop drawings. Marking shall be done by die stamping the marks into the metal before galvanizing and shall be clearly legible after galvanizing. The number and letter shall be a minimum of 12 mm in height and 8 mm wide.

Each supporting structure shall be provided with mounting holes for fixing of junction box and shall be equipped with clamp-type ground terminal connector suitable for No 4/0 AWG copper stranded conductor.

**751-6 Special Requirement.** In case of inverted type (top core) is proposed for 230 kV current transformer and below, type test record of multiple chopped impulse test shall be submitted together with tender document during the bidding. This type test record shall be submitted as required evidence for consideration of evaluation.

In case of inverted type (top core) is proposed for 500 kV current transformer, type test procedure of multiple chopped impulse test shall be submitted together with tender document during the bidding. The actual test for multiple chopped impulse test which conform to approved test procedure during the bidding shall be

performed after confirmation letter of award of Contract. This actual test may be omitted if a type test record of same type and similar rating unit can be submitted together with tender document during the bidding.

**751-7 Test.** Test of equipment shall be performed according to the requirements specified in each referred test item. The costs of all tests and reports shall be borne by the Contractor.

**751-7.1 Type Test.** The proposed equipment shall already have the type test record of the same type and similar rating as EGAT called for, in accordance with the tests specified in test items, which is subject to EGAT's approval (unless otherwise specified in each test item). In case of the type and similar rating of equipment as proposed has never been accepted by EGAT, the type test record shall be required and submitted together with the tender document during the bidding.

**751-7.2 Routine Test.** Each equipment shall be completely assembled at the factory and subject to the tests specified in each test item.

**751-7.3 Test Report.** The report of all tests, curves and standard application data shall be furnished to EGAT immediately after completion of the tests.

**751-7.4 Test Procedure.** The Contractor shall submit the test procedure of routine tests and actual type tests to EGAT for approval. The test procedure shall consist of procedures, applied voltage, current and criteria to justify the result of the tests.

**751-7.5 Test Items for Current Transformer.** The tests shall be performed in accordance with the latest IEC standard.

Test in according to IEC Std 61869-1, 61869-2 are as following.

**a. Type Tests**

- (a) Short-time current tests.
- (b) Temperature-rise test.
- (c) Wet test for outdoor type transformers.
- (d) Impulse voltage withstand test (including chopped impulse voltage withstand test).
- (e) Multiple chopped impulse test.

The type test record, in accordance with the following items below, of the inverted type (top core) current transformer, which is subject to EGAT's approval, is required and shall be submitted together with tender document during the bidding.



*Sotraside Hirinam*

If actual multiple chopped impulse test is required to be performed, the current transformer required for the test shall be subject to the sequence of tests listed below.

1. Routine test for item (a), (g) and (h) according to the requirements of this specification and oil sampling for dissolved gas analysis before multiple chopped impulse test.
2. Apply a series of 12 sets of 50 chopped waves impulse of negative polarity (total of 600 chopped waves impulse) at the rate of, about 1 impulse per minute.

The test voltage amplitude shall be approximately 70% of the BIL rating (with the tolerance of  $\pm 5\%$ ). The chopping time shall be within 0.5  $\mu\text{s}$  after reaching the crest voltage. The waveshape oscillogram and the total secondary current shall be recorded on the first chopped wave application and every 50<sup>th</sup> chopped wave application.

3. Routine tests for item (a), (g) and (h) according to the requirements of this specification.
4. 72 hours after completion of all tests, oil sampling for dissolved gas analysis shall be carried out.

The maximum increase of the content of the following gases shall be as follows :

H<sub>2</sub> : 5 ppm , CH<sub>4</sub> : 2 ppm , C<sub>2</sub>H<sub>6</sub> : 2 ppm ,  
C<sub>2</sub>H<sub>2</sub> : 1 ppm , C<sub>2</sub>H<sub>4</sub> : 1 ppm

- (f) Switching impulse voltage test (for 500 kV Current Transformer).
- (g) Transient performance test (if required in Ratings and Features sheet).
- (h) Tests for accuracy.
- (i) Electromagnetic compatibility tests.

#### b. Routine Tests

- (a) Power frequency voltage withstand test.
- (b) Inter-turn overvoltage test.

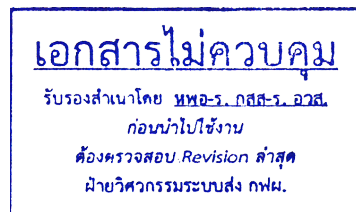

31 มีนาคม 2569

*Sotrajit Hirinam*

- (c) Tests for accuracy for each ratio of all windings (including excitation curve of one unit of each item for relaying class). Reduced number of currents and/or burdens are not acceptable.
- (d) Verification of markings.
- (e) Determination of the secondary winding resistance for maximum ratio of all windings but one unit of each item shall be performed for each ratio of all windings.
- (f) Insulation resistance measurement. This test shall be performed at tested voltage 2500 Vdc for the winding which voltage rating  $\geq 3300$  V and 500 Vdc for the winding which voltage rating  $< 3300$  V. The test result shall be more than 1000 M $\Omega$  for primary winding and more than 10 M $\Omega$  for secondary winding.
- (g) Measurement of capacitance and dielectric dissipation factor. (This test result shall be provided for every rating)
- (h) Partial discharge measurement.
- (i) Determination of the secondary loop time constant. (for TPY class)
- (j) Enclosure tightness test at ambient temperature.
- (k) Creepage distance measurement. One unit of each type and rating shall be subject to this test.

**เอกสารไม่ควบคุม**

รับรองสำเนาโดย พทอ.ร. กสส.ร. อวส.

ก่อนนำไปใช้งาน

ต้องตรวจสอบ.Revision ล่าสุด

ฝ่ายวิศวกรรมระบบส่ง กฟผ.

31 มีนาคม 2569

*Sotrasida Hmimom*

## 751-8 Drawings and Documents for Current Transformer

Drawings and documents shall at least comprise the followings:

### A. Drawings for Approval

Item	Description	Approval and Final Dwgs	Autocad files	CD-ROM or Other Storage Device
1	Outline drawing	X	X	X
2	Nameplate including ratings, connection diagram and EGAT's Contract No, Item No and EGAT Serial No	X	X	X
3	Line terminal pad	X	-	X
4	Ground terminal connector	X	-	X
5	Detail of secondary terminal box	X	-	X
6	Steel supporting structure (if any) including bill of material	X	X	X
7	Detail of primary protective device (if any)	X	-	X
8	Assembly drawing of equipment completed with steel supporting structure	X	X	X

### B. Drawing and Documents for Reference

1. Internal cross-section view
2. Characteristics of insulating oil

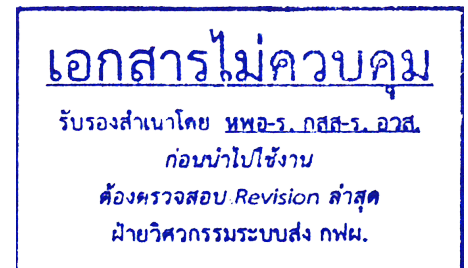

31 มีนาคม 2569

*Sotrasida Hinnam*

## 751-9 Instruction Manual for Current Transformer

Instruction manual shall consist of all necessary information and shall comprise of at least the following parts:

**Part A** Current transformer instruction including installation, operation and maintenance.

- a. Current transformer general technical information.
- b. Installation instruction including but not limited to
  - Transportation
  - Inspection
  - Installation instruction
  - Method of oil filling
  - Characteristics of insulating oil
  - Oil temperature-oil level curve (if any)
- c. Operation and maintenance instruction
  - Routine inspection
  - Maintenance
- d. Catalogs

**Part B** Complete set of all final drawings and/or documents arranged in order of each complete item.

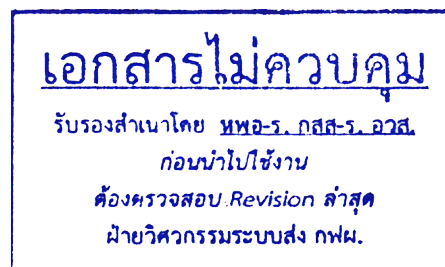

31 มีนาคม 2569

*Sotarakid Hmimom*

## Specification No 761

### Oil-filled Coupling Capacitor Voltage Transformer

**761-1 General.** This specification covers the general requirements for design, manufacture, test and supply of coupling capacitor voltage transformer (CCVT).

The specific ratings, characteristics and the special requirements and features of the equipment not covered herein are given in the accompanying Ratings and Features sheet (if any).

**761-2 Materials and Workmanship.** All materials shall be new and shall be the best available for the purposes used, considering strength, ductility, durability and suitability for the intended services and best engineering practice. Workmanship shall be of the highest grade and in accordance with the best modern standard practice.

**761-3 Service Conditions.** All materials shall be suitable for installation and use at an altitude of 1000 m or less in a tropical climate with a maximum ambient temperature of 45°C and 100% relative humidity for outdoor equipment (or a maximum ambient temperature of 40°C and 90% relative humidity for indoor equipment) without corrosion, deterioration or degradation of performance characteristics.

**761-4 Codes and Standards.** All equipment, materials, devices, fabrication and testing shall conform to the codes, specifications and standards listed below and all applicable codes, specifications and standard referred therein.

ANSI	American National Standards Institute
ASME	American Society of Mechanical Engineers
ASTM	American Society for Testing and Materials
AWS	American Welding Society
IEC	International Electrotechnical Commission
IEEE	The Institute of Electrical and Electronics Engineers
NEMA	National Electrical Manufacturers Association

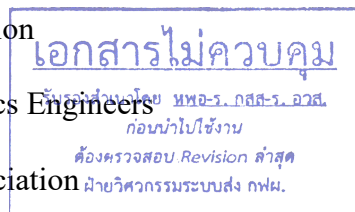

31 มีนาคม 2569

All threaded parts requiring external connection shall have metric screw and pipe threads. All internal parts may have threads in accordance with the established specification in the country of manufacturer.

It is the intent that all equipment, materials, devices, fabrication and testing shall conform to the application codes, specifications and standards even though they are not specifically noted herein. Equivalent codes, specifications and standards established and approved in the country of equipment or material manufacture may be used subject to EGAT's approval. If this election is made, the Bidder shall

so state and include in his bid the governing codes, specifications, and standards proposed together with an itemized list of specific deviations from the requirements of codes, specifications and standards referred herein.

The latest issue of all codes, specifications and standards shall govern.

The most stringent requirement, in the event of code, specification or standard conflict, shall govern. This specification shall govern in the event of discrepancies between it and applicable codes, specifications and standards.

## 761-5 Design and Construction

**761-5.1 Type and Construction.** The type and ratings of equipment shall be in accordance with the accompanying Ratings and Features sheet.

The expansion system for changing of oil volume to variation in oil transformer shall be metallic bellow, other oil expansion systems are not acceptable.

The coupling capacitor voltage transformer with core molded or encapsulated in epoxy resin or located in porcelain housing is not acceptable.

The both ends of porcelain housing shall be cemented to the transformer base and head flanges. The porcelain which is fixed by clamps is not acceptable.

A meaningful ferro-resonance circuit shall be provided for effective suppression of ferroresonance conditions. Ferroresonance suppression device used of electronic circuit is not acceptable.

The coupling capacitor voltage transformer secondary circuit connection to ground, the carrier lead-in terminal and carrier drain coil grounding terminal of coupling capacitor voltage transformer shall be made in such a way as to permit convenient temporary removal for isolation or testing.

**761-5.2 Terminal Pad.** Each equipment terminal for connecting to the line or other equipment shall be equipped with a suitable terminal pad unless otherwise specified. The terminal pad shall be provided with 14.3 mm (9/16 in) diameter holes with 45 mm (1-3/4 in) spacing between the centers of each hole in accordance with the NEMA Standards CC1, number of holes specified in Ratings and Features sheet.

The terminal pad shall be of high conductivity bronze, copper or aluminum alloy and, unless it is made of aluminum alloy, shall be plated with electro-tin to a thickness of not less than 0.0127 mm (0.0005 in).

**761-5.3 Porcelain Housings.** Porcelain housings shall have adequate mechanical and electrical strength. The color of porcelain shall be of chocolate brown. Porcelain housings shall be wet process, homogeneous and free

from cavities or other flaws. The glazing shall be uniform in color and free from blisters, burns and other defects.

**761-5.4 Ground Terminal Connectors.** Two (2) units of ground terminal connectors shall be of the clamp type suitable for No 4/0 AWG copper stranded conductor. Terminal connector shall be made of high conductivity material and shall be completed with corrosion resistance bolts, nuts and lock washers.

**761-5.5 Secondary Terminal Box.** Degree of protection for secondary terminal box shall be at least IP54.

A hole shall be provided at the bottom of secondary terminal box suitable for 2 in (outside diameter of 62 mm) rigid steel conduit.

Bottom hole shall be knock-out type or furnished with suitable cover to prevent internal devices of secondary terminal boxes during transportation and storage.

**761-5.6 Terminations.** All coupling capacitor voltage transformer secondary terminals which connected to terminals on terminal blocks located in the junction boxes, shall have the size suitable for termination of 4 mm<sup>2</sup> cable and shall be ring tongue crimp type. All coupling capacitor voltage transformers completed with carrier accessories shall be equipped with carrier terminal connectors suitable for 16 mm<sup>2</sup> copper cable and located inside of secondary terminal box for easy access of connection. The cable hole with cable gland suitable for 18 mm outside diameter cable shall be provided at the bottom of secondary terminal box. The insulation level of carrier terminal shall be the same as carrier drain coil as specified in Ratings and Features sheet.

**761-5.7 Supporting Structures.** Supporting structures, if specified in the Price Schedule, shall be hot-dip galvanized after fabrication in accordance with ASTM A123, A153 and A53. All necessary galvanized bolts, nuts and washers to complete the erection shall be furnished including embedded anchor bolts for securing the supporting structures to the concrete foundation.

The galvanizing coating shall meet the values as shown in the following table.

**เอกสารไม่ควบคุม**  
 วิศวกรควบคุมงานก่อสร้าง-ร.อ.ส.  
 ก่อนนำไปใช้งาน  
 ต้องตรวจสอบ Revision ล่าสุด  
 ฝ่ายวิศวกรรมระบบส่ง กฟผ.

31 มีนาคม 2569

**Galvanizing Coating Weight**

Description	Thickness	Coating Weight (g/m <sup>2</sup> )	
		Average Value	Minimum Value
Shaped steel and steel plate	6 mm and over	more than 702	more than 610
	under 6 mm	more than 610	more than 550
Steel pipe	-	more than 550	more than 490
Bolts, nuts	-	more than 381	more than 305
Washers, filters	5 mm and over	more than 381	more than 305
	under 5 mm	more than 305	more than 259

Finished materials shall be dipped into the solution of dichromate after galvanizing for white rust protection.

**Marking.** all individual pieces shall be marked with the correct designations shown on the approved shop drawings. Marking shall be done by die stamping the marks into the metal before galvanizing and shall be clearly legible after galvanizing. The number and letter shall be a minimum of 12 mm in height and 8 mm wide.

Each supporting structure shall be provided with mounting holes for fixing of junction box and shall be equipped with clamp-type ground terminal connector suitable for No 4/0 AWG copper stranded conductor.

**761-6 Test.** Test of equipment shall be performed according to the requirements specified in each referred test item. The costs of all tests and reports shall be borne by the Contractor.

**761-6.1 Type Test.** The proposed equipment shall already have the type test record of the same type and similar rating as EGAT called for, in accordance with the tests specified in test items, which is subject to EGAT's approval (unless otherwise specified in each test item). In case of the type and similar rating of equipment as proposed has never been accepted by EGAT, the type test record shall be required and submitted together with the tender document during the bidding.

**761-6.2 Routine Test.** Each equipment shall be completely assembled at the factory and subject to the tests specified in each test item.

**761-6.3 Test Report.** The report of all tests, curves and standard application data shall be furnished to EGAT immediately after completion of the tests.

**761-6.4 Test Procedure.** The Contractor shall submit the test procedure of routine tests and actual type tests to EGAT for approval. The test procedure shall consist of procedures, applied voltage, current and criteria to justify the result of the tests.

**761-6.5 Test item for Coupling Capacitor Voltage Transformer.** The tests shall be performed in accordance with the latest IEC Std 61869-1, 61869-5 as following requirements.

**a. Type Tests**

- (a) Temperature-rise test. These tests shall be carried out to verify the thermal limiting output in accordance with IEC 61869-5. The test shall include item (a), and either item (b) or (c), depending on the applicable voltage factor.
- (b) Chopped impulse test.
- (c) Impulse voltage test on primary terminals

เอกสารไม่ควบคุม  
รับรองสำเนาโดย มหอร. กสส.ร. อวส.  
ก่อนนำไปใช้งาน  
ต้องตรวจสอบ.Revision สำสุด  
ฝ่ายวิศวกรรมระบบส่ง กฟผ.

31 มีนาคม 2569

- (d) Wet test for outdoor type transformers
- (e) Electromagnetic Compatibility tests
- (f) Test for accuracy
- (g) Verification of the degree of protection by enclosures
- (h) Enclosure tightness test at ambient temperature
- (i) Capacitance and  $\tan\delta$  measurement at power frequency
- (j) Short circuit withstand capability test
- (k) Ferro-resonance test
- (l) Transient response test
- (m) Type tests for carrier frequency accessories
- (n) Mechanical endurance test for EMU potential grounding switch.
  - 1000 opening and closing tests on the EMU potential grounding switch at ambient temperature shall be conducted, the potential grounding switch after the test shall have no damage or wear conditions.

**b. Routine Tests**

- (a) Power-frequency voltage withstand tests on primary terminals
- (b) Partial discharge measurement
- (c) Power-frequency voltage withstand tests between sections
- (d) Power-frequency voltage withstand tests on secondary terminals
- (e) Test for accuracy
- (f) Verification of markings
- (g) Enclosure tightness test at ambient temperature.
- (h) Ferro-resonance check.
- (i) Routine tests for carrier frequency accessories
- (j) Creepage distance measurement. One unit of each type and rating shall be subject to this test.

**เอกสารไม่ควบคุม**  
 รับรองสำเนาโดย นพอ.ร.กสส.ร.อวส.  
 ก่อนนำไปใช้งาน  
 ต้องตรวจสอบ Revision ล่าสุด  
 ฝ่ายวิศวกรรมระบบส่ง กฟผ.

31 มีนาคม 2569

- (k) Mechanical function check for EMU potential grounding switch. The actual test shall be performed on one unit of CCVT being supplied as per Ratings and Features sheet.
- 5 opening and closing tests on the EMU potential grounding switch at ambient temperature shall be conducted, the potential grounding switch after the test shall have no damage or wear conditions.

Bid No. NPUP-MJ1-02 and LPLC-MJ1-01  
**DRAFT**

**เอกสารไม่ควบคุม**

รับรองสำเนาโดย **ทพอ.ร. กสส.ร. อวส.**

ก่อนนำไปใช้งาน

ต้องตรวจสอบ **Revision** สำสุด

ฝ่ายวิศวกรรมระบบส่ง กฟผ.

31 มีนาคม 2569

## 761-7 Drawings and Documents for Coupling Capacitor Voltage Transformer

Drawings and documents shall at least comprise the followings:

### A. Drawings for Approval

Item	Description	Approval and Final DWGS	Autocad files	CD-ROM or Other Storage Device
1	Outline drawing	X	X	X
2	Nameplate including ratings, connection diagram and EGAT's Contract No, Item No and EGAT Serial No.	X	X	X
3	Line terminal pad	X	-	X
4	Ground terminal connector	X	-	X
5	Detail of secondary terminal box	X	-	X
6	Steel supporting structure (if any) including bill of material	X	X	X
7	Detail of carrier terminal and accessories	X	-	X
8	Assembly drawing of equipment completed with steel supporting structure	X	X	X

### B. Drawing and Documents for Reference

1. Internal cross-section view
2. Characteristics of insulating oil

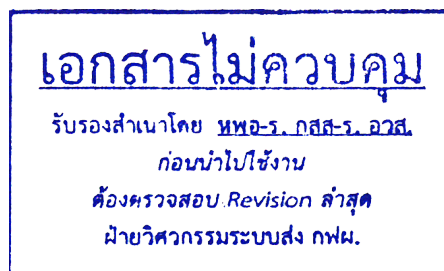

31 มีนาคม 2569

*Soravida Arnonan*

## 761-8 Instruction Manual for Coupling capacitor voltage transformer

Instruction manual shall consist of all necessary information and shall comprise of at least the following parts:

**Part A** Coupling capacitor voltage transformer instruction including installation, operation and maintenance.

a. Coupling capacitor voltage transformer general technical information.

b. Installation instruction including but not limited to

- Transportation
- Inspection
- Installation instruction
- Method of oil filling
- Characteristics of insulating oil
- Oil temperature-oil level curve (if any)

c. Operation and maintenance instruction

- Method of adjustment of transformer ratio and phase angle
- Method of reactor tuning
- Routine inspection
- Maintenance

d. Catalogs

**Part B** Complete set of all final drawings and/or documents arranged in order of each complete item.

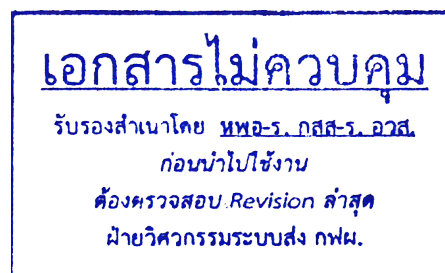

31 มีนาคม 2569

*Soravit Amorn*

## Specification No 762

### Oil-filled Inductive Voltage Transformer

**762-1 General.** This specification covers the general requirements for design, manufacture, test and supply of inductive voltage transformer (IVT).

The specific ratings, characteristics and the special requirements and features of the equipment not covered herein are given in the accompanying Ratings and Features sheet (if any).

**762-2 Materials and Workmanship.** All materials shall be new and shall be the best available for the purposes used, considering strength, ductility, durability and suitability for the intended services and best engineering practice. Workmanship shall be of the highest grade and in accordance with the best modern standard practice.

**762-3 Service Conditions.** All materials shall be suitable for installation and use at an altitude of 1000 m or less in a tropical climate with a maximum ambient temperature of 45°C and 100% relative humidity for outdoor equipment (or a maximum ambient temperature of 40°C and 90% relative humidity for indoor equipment) without corrosion, deterioration or degradation of performance characteristics.

**762-4 Codes and Standards.** All equipment, materials, devices, fabrication and testing shall conform to the codes, specifications and standards listed below and all applicable codes, specifications and standard referred therein.

ANSI	American National Standards Institute
ASME	American Society of Mechanical Engineers
ASTM	American Society for Testing and Materials
AWS	American Welding Society
IEC	International Electrotechnical Commission
IEEE	The Institute of Electrical and Electronics Engineers
NEMA	National Electrical Manufacturers Association

เอกสารไม่ควบคุม

รับรองสำเนาโดย มหอ-ร. กสส-ร. อวส.

ก่อนนำไปใช้งาน

ต้องตรวจสอบ .Revision ล่าสุด

ฝ่ายวิศวกรรมระบบส่ง กฟผ.

31 มีนาคม 2569

All threaded parts requiring external connection shall have metric screw and pipe threads. All internal parts may have threads in accordance with the established specification in the country of manufacturer.

It is the intent that all equipment, materials, devices, fabrication and testing shall conform to the application codes, specifications and standards even though they are not specifically noted herein. Equivalent codes, specifications and standards established and approved in the country of equipment or material manufacture may be used subject to EGAT's approval. If this election is made, the Bidder shall

so state and include in his bid the governing codes, specifications, and standards proposed together with an itemized list of specific deviations from the requirements of codes, specifications and standards referred herein.

The latest issue of all codes, specifications and standards shall govern.

The most stringent requirement, in the event of code, specification or standard conflict, shall govern. This specification shall govern in the event of discrepancies between it and applicable codes, specifications and standards.

## 762-5 Design and Construction

**762-5.1 Type and Construction.** The type and ratings of equipment shall be in accordance with the accompanying Ratings and Features sheet.

The expansion system for changing of oil volume to variation in oil transformer metallic bellow, other oil expansion systems are not acceptable.

The inductive voltage transformer with core molded or encapsulated in epoxy resin or located in porcelain housing is not acceptable.

The both ends of porcelain housing shall be cemented to the transformer base and head flanges. The porcelain which is fixed by clamps is not acceptable.

**762-5.2 Terminal Pad.** Each equipment terminals for connecting to the line or other equipment shall be equipped with a suitable terminal pad unless otherwise specified. The terminal pad shall be provided with 14.3 mm (9/16 in) diameter holes with 45 mm (1-3/4 in) spacing between the centers of each hole in accordance with the NEMA Standards CC1, number of holes specified in Ratings and Features sheet.

The terminal pad shall be of high conductivity bronze, copper or aluminum alloy and, unless it is made of aluminum alloy, shall be plated with electro-tin to a thickness of not less than 0.0127 mm (0.0005 in).

**762-5.3 Porcelain Housings.** Porcelain housings shall have adequate mechanical and electrical strength. The color of porcelain shall be of chocolate brown. Porcelain housings shall be wet process, homogeneous and free from cavities or other flaws. The glazing shall be uniform in color and free from blisters, burns and other defects.

**762-5.4 Ground Terminal Connectors.** Two (2) units of ground terminal connectors shall be of the clamp type suitable for No 4/0 AWG copper stranded conductor. Terminal connector shall be made of high conductivity material and shall be completed with corrosion resistance bolts, nuts and lock washers.

**762-5.5 Secondary Terminal Box.** Degree of protection for secondary terminal box shall be at least IP54.

a. **For 69 kV Inductive Voltage Transformer and above.** A hole shall be provided at the bottom of secondary terminal box suitable for 2 in (outside diameter of 62 mm) rigid steel conduit.

Bottom hole shall be knock-out type or furnished with suitable cover to prevent internal devices of secondary terminal boxes during transportation and storage.

b. **For 33 kV Inductive Voltage Transformer and below.** Flexible sealing cable gland shall be provided for one set of cable at the bottom of secondary terminal box suitable for cable of 26 mm outside diameter.

**762-5.6 Terminations.** All inductive voltage transformer secondary terminals which connected to terminals on terminal blocks located in the junction boxes, shall have the size suitable for termination of 4 mm<sup>2</sup> cable and shall be ring tongue crimp type.

**762-5.7 Supporting Structures.** Supporting structures, if specified in the Price Schedule, shall be hot-dip galvanized after fabrication in accordance with ASTM A123, A153 and A53. All necessary galvanized bolts, nuts and washers to complete the erection shall be furnished including embedded anchor bolts for securing the supporting structures to the concrete foundation.

The galvanizing coating shall meet the values as shown in the following table.

**Galvanizing Coating Weight**

Description	Thickness	Coating Weight (g/m <sup>2</sup> )	
		Average Value	Minimum Value
Shaped steel and steel plate	6 mm and over under 6 mm	more than 702 more than 610	more than 610 more than 550
Steel pipe	-	more than 550	more than 490
Bolts, nuts	-	more than 381	more than 305
Washers, filters	5 mm and over under 5 mm	more than 381 more than 305	more than 305 more than 259

Finished materials shall be dipped into the solution of dichromate after galvanizing for white rust protection.

**Marking.** all individual pieces shall be marked with the correct designations shown on the approved shop drawings. Marking shall be done by die stamping the marks into the metal before galvanizing and shall be clearly legible after galvanizing. The number and letter shall be a minimum of 12 mm in height and 8 mm wide.

Each supporting structure shall be provided with mounting holes for fixing of junction box and shall be equipped with clamp-type ground terminal connector suitable for No 4/0 AWG copper stranded conductor.

*Soravit Anuman*

**เอกสารลับ**

รับรองสำเนาโดย พหุ-ร. กสส-ร. อวส.  
ก่อนนำไปใช้งาน

Aug 2025

ฝ่ายวิศวกรรมระบบส่ง กฟผ.

**762-6 Test.** Test of equipment shall be performed according to the requirements specified in each referred test item. The costs of all tests and reports shall be borne by the Contractor.

**762-6.1 Type Test.** The proposed equipment shall already have the type test record of the same type and similar rating as EGAT called for, in accordance with the tests specified in test items, which is subject to EGAT's approval (unless otherwise specified in each test item). In case of the type and rating of equipment as proposed has never been accepted by EGAT, the type test record shall be required and submitted together with the tender document during the bidding.

**762-6.2 Routine Test.** Each equipment shall be completely assembled at the factory and subject to the tests specified in each test item.

**762-6.3 Test Report.** The report of all tests, curves and standard application data shall be furnished to EGAT immediately after completion of the tests.

**762-6.4 Test Procedure.** The Contractor shall submit the test procedure of routine tests and actual type tests to EGAT for approval. The test procedure shall consist of procedures, applied voltage, current and criteria to justify the result of the tests.

**762-6.5 Test Items for Inductive Voltage Transformer.** The tests shall be performed in accordance with the latest IEC Std 61869-1, 61869-3 as following requirements.

**a. Type Tests**

(a) Temperature-rise test. (These tests shall be carried out to verify the thermal limiting output in accordance with IEC 61869-3. The test shall include item (a), and either item (b) or (c), depending on the applicable voltage factor.)

(b) Impulse voltage test on primary terminals. (Including chopped impulse voltage withstand test on primary terminals).

(c) Wet test for outdoor type transformers.

(d) Electromagnetic Compatibility tests.

(e) Test for accuracy.

(f) Verification of the degree of protection by enclosures

(g) Short-circuit withstand capability test.

**เอกสารไม่ควบคุม**

รับรองสำเนาโดย นพอ.ร. กสส.ร. อวส.

ก่อนนำไปใช้งาน

ต้องตรวจสอบ Revision สำคัญ

ฝ่ายวิศวกรรมระบบส่ง กฟผ.

31 มีนาคม 2569

**b. Routine Tests**

- (a) Power-frequency voltage withstand tests on primary terminals.
- (b) Partial discharge measurement.
- (c) Power-frequency voltage withstand tests between sections.
- (d) Power-frequency voltage withstand tests on secondary terminals.
- (e) Test for accuracy.
- (f) Verification of markings.
- (g) Enclosure tightness test at ambient temperature.
- (h) Measurement of capacitance and dielectric dissipation factor.
- (i) Winding resistance measurement for each ratio of all windings
- (j) Insulation resistance measurement
- (k) Creepage distance measurement. One unit of each type and rating shall be subject to this test.

*Soravit Arimman*

**เอกสารไม่ควบคุม**

รับรองสำเนาโดย **ทพอ.ร.กสส.ร.อวส.**  
ก่อนนำไปใช้งาน  
ต้องตรวจสอบ **Revision** สำสุด  
ฝ่ายวิศวกรรมระบบส่ง กฟผ.

31 มีนาคม 2569

## 762-7 Drawings and Documents for Inductive Voltage Transformer

Drawings and documents shall at least comprise the followings:

### A. Drawings for Approval

Item	Description	Approval and Final Dwgs	Autocad files	CD-ROM or Other Storage Device
1	Outline drawing	x	x	x
2	Nameplate including ratings, connection diagram and EGAT's Contract No, Item No and EGAT Serial No	x	x	x
3	Line terminal pad	x	-	x
4	Ground terminal connector	x	-	x
5	Detail of secondary terminal box	x	-	x
6	Steel supporting structure (if any) including bill of material	x	x	x
7	Assembly drawing of equipment completed with steel supporting structure	x	x	x

### B. Drawing and Documents for Reference

1. Internal cross-section view
2. Characteristics of insulating oil

*Soravit Aniraman*

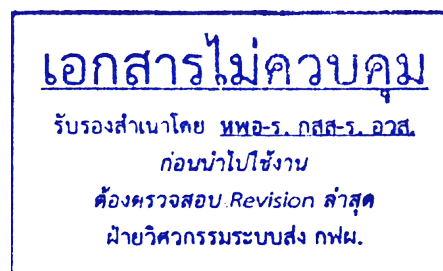

31 มีนาคม 2569

## 762-8 Instruction Manual for Inductive Voltage Transformer

Instruction manual shall consist of all necessary information and shall comprise of at least the following parts:

**Part A** Inductive voltage transformer instruction including installation, operation and maintenance.

a. Inductive voltage transformer general technical information.

b. Installation instruction including but not limited to

- Transportation

- Inspection

- Installation instruction

- Method of oil filling

- Characteristics of insulating oil

- Oil temperature-oil level curve (if any)

c. Operation and maintenance instruction

- Routine inspection

Maintenance

d. Catalogs

**Part B** Complete set of all final drawings and/or documents arranged in order of each complete item.

*Soravit Anomman*

**เอกสารไม่ควบคุม**

รับรองสำเนาโดย **ทพอ.ร.กสส.ร.อวส.**

ก่อนนำไปใช้งาน

ต้องตรวจสอบ **Revision** สำสุด

ฝ่ายวิศวกรรมระบบส่ง กฟผ.

31 มีนาคม 2569

**DRAFT**

**SECTION J  
DRAWINGS**

## J. DRAWINGS

### J-1. Drawings

The following drawings are attached hereto and made a part of the Contract Documents:

<b>No.</b>	<b>Description</b>	<b>Dwg. No.</b>	<b>Sheet</b>	<b>Rev.</b>
01	CURRENT TRANSFORMER STRUCTURE	ST-CT-9-01	01/01	-
02	500 KV COUPLING CAPACITOR VOLTAGE TRANSFORMER STRUCTURE	ST-VT-9-01	01/01	1
03	DETAILS OF STANDARD BOLTS, NUTS, RING FILLERS, SPRING LOCK WASHERS	SD-AB-0-01	01/01	7

DRAFT

ITEM	DESCRIPTION	STR. MKD.	TOTAL HEIGHT (mm.)	REMARK
1	500KV. CURRENT TRANSFORMER SUPPORT STRUCTURE	CT901	9000	

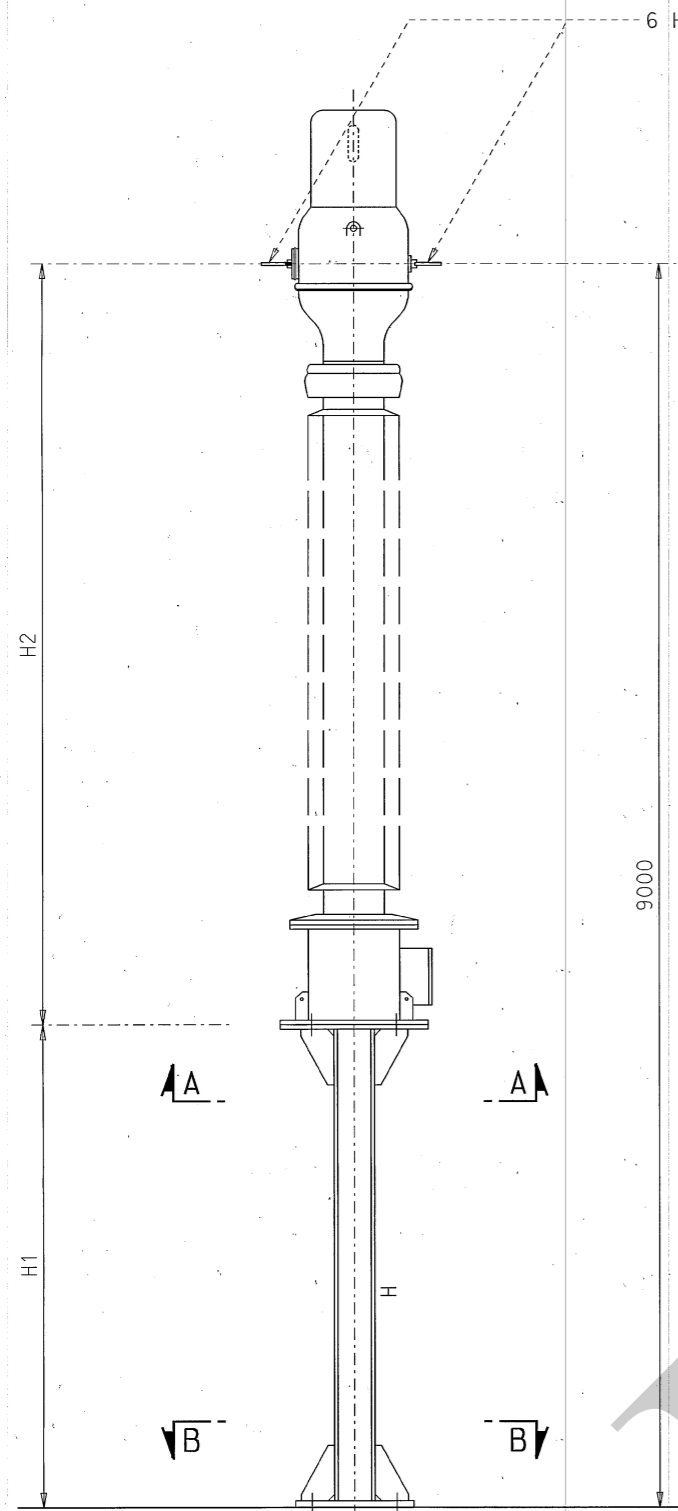

ELEVATION

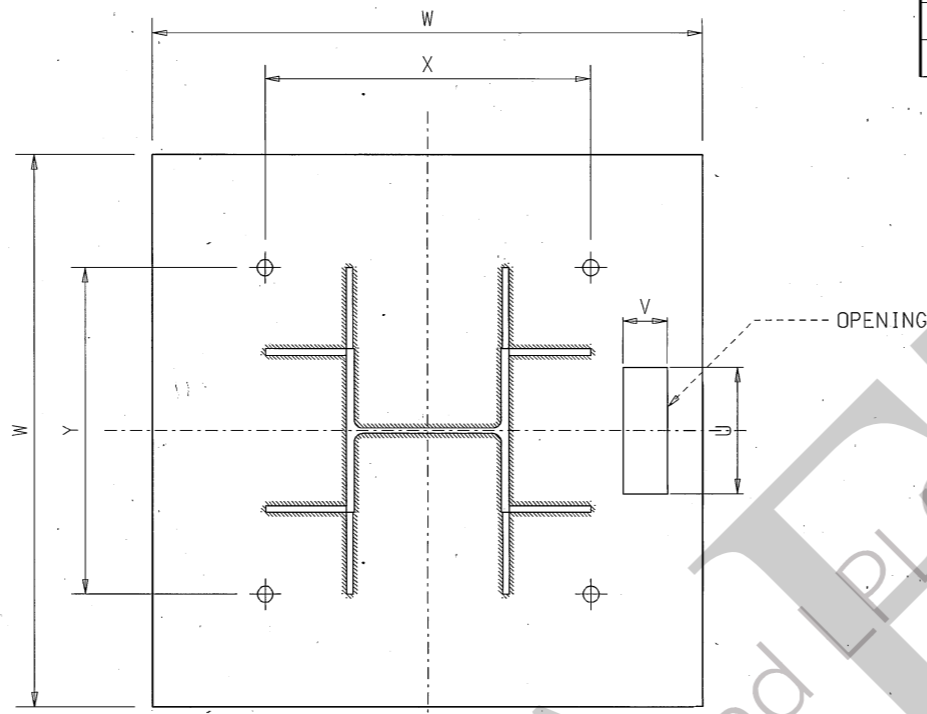

SECTION A-A

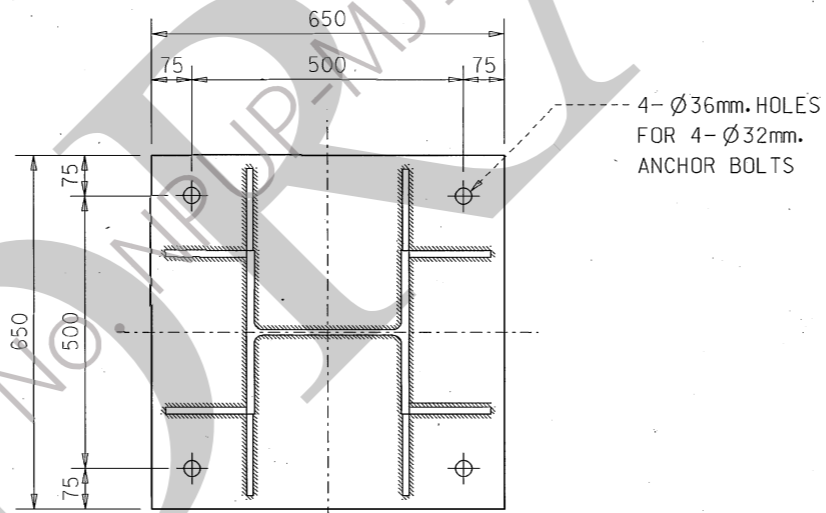

SECTION B-B

NOTES

- ALL DIMENSIONS ARE IN MILLIMETERS, EXCEPT OTHERWISE SHOWN.
- QUALITY OF MATERIALS
  - ALL MEMBERS SHALL CONFORM TO ASTM A36 OR EQUIVALENT.
  - ALL BOLTS AND NUTS SHALL CONFORM TO ASTM A394 TYPE "O" OR EQUIVALENT.
  - SPRING WASHERS SHALL BE CARBON STEEL CONFORMING TO ASA B27.1, REGULAR TYPE.
- ALL MATERIALS SHALL BE HOT-DIP GALVANIZED AFTER FABRICATION AND CLEANING.
  - ALL MEMBERS AND PLATES SHALL CONFORM TO ASTM A123
  - ALL BOLTS AND NUTS SHALL CONFORM TO ASTM A153
- FINISHED MATERIALS SHALL BE DIPPED INTO THE SOLUTION OF DICHROMATE AFTER GALVANIZING FOR WHITE RUST PROTECTION.
- STANDARD GAUGE OF MEMBERS ARE HALF OF FLANGE, EXCEPT OTHERWISE SHOWN.
- THE DIMENSION U,V,W,X,Y DEPENDING ON MANUFACTURER'S EQUIPMENT SHALL BE ASSIGNED BY THE CONTRACTOR.
- THE DETAIL DESIGN FOR INSTALLATION OF ACCESSORIES PART OF EQUIPMENT AND STEEL STRUCTURE SHALL BE ASSIGNED BY THE CONTRACTOR.
- DETAIL OF STANDARD BOLTS, NUTS AND ANCHOR BOLTS SEE DWG.NO.SD-AB-0-01,01/01 (REV.2).

**เอกสารไม่ควบคุม**  
 รับรองสำเนาโดย พทอ.ร. กสส.ร. อวส.  
 ก่อนนำไปใช้งาน  
 ต้องตรวจสอบ Revision ล่าสุด  
 ฝ่ายวิศวกรรมระบบส่ง กฟผ.

31 มีนาคม 2569

REV. NO.	JOB NO.	JOB DESCRIPTION	DRAWN	DESIGNED	VERIFIED	VALIDATED	RECOMMENDED	CONCURRED	APPROVED	DATE

ELECTRICITY GENERATING AUTHORITY OF THAILAND									
DRAWN	P. SORNSIT	VALIDATED	C. Sidarat CHIEF, SUBSTATION ENGINEERING DEPARTMENT		DRAWING NAME				
DESIGNED	P. KORANBE	RECOMMENDED	S. Poon ASSISTANT DIRECTOR, TRANSMISSION SYSTEM ENGINEERING DIVISION		TYPICAL DRAWING				
VERIFIED	U. Jachavan	CONCURRED	S. De DIRECTOR, TRANSMISSION SYSTEM ENGINEERING DIVISION		DESCRIPTION OF DETAIL DRAWING				
APPROVED	J. U.	DATE	25/10/08		CURRENT TRANSFORMER STRUCTURE				
JOB NO.		REPLACING DWG. NO.		DWG. NO.		JOB NO.		REV.	
				ST-CT-9-01				01 / 01	

10-6-1A-1S ON 0MD  
 DWG. NO.

ITEM	DESCRIPTION	STR. MKD.	TOTAL HEIGHT (mm.)	REMARK
1	500KV. COUPLING CAPACITOR VOLTAGE TRANSFORMER	VT901	9000	
	SUPPORT STRUCTURE			

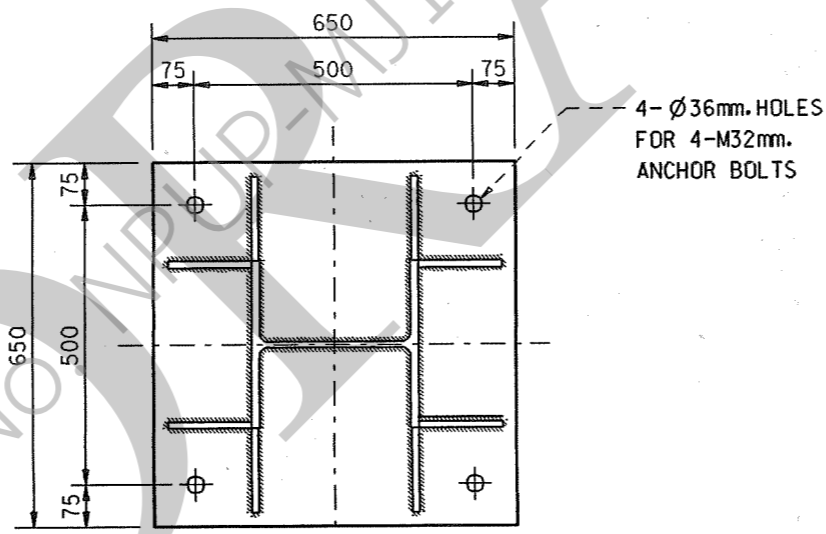
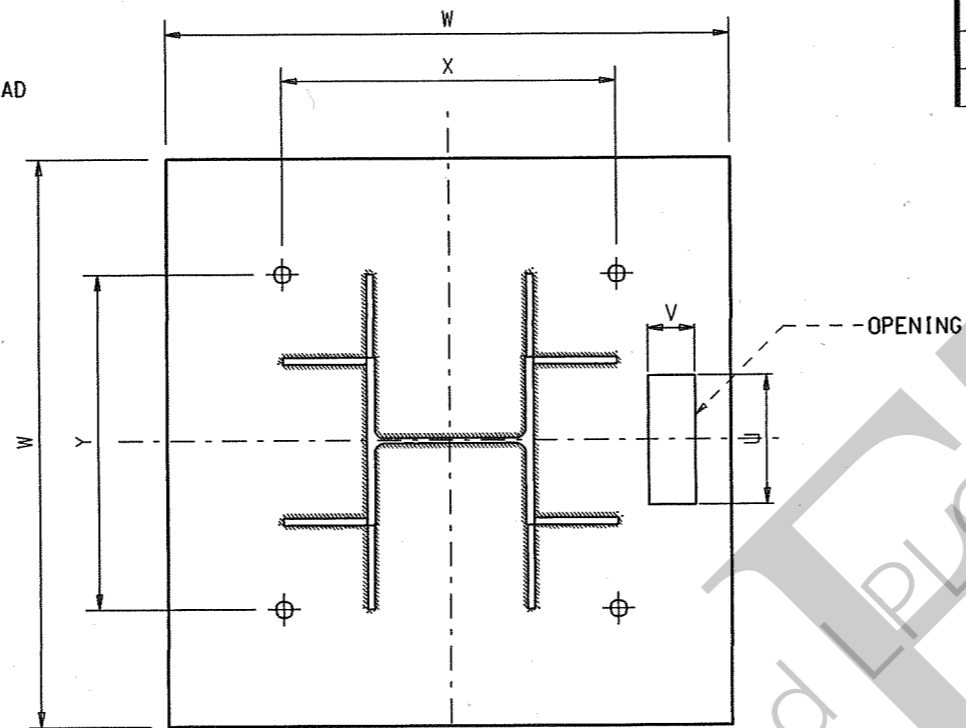
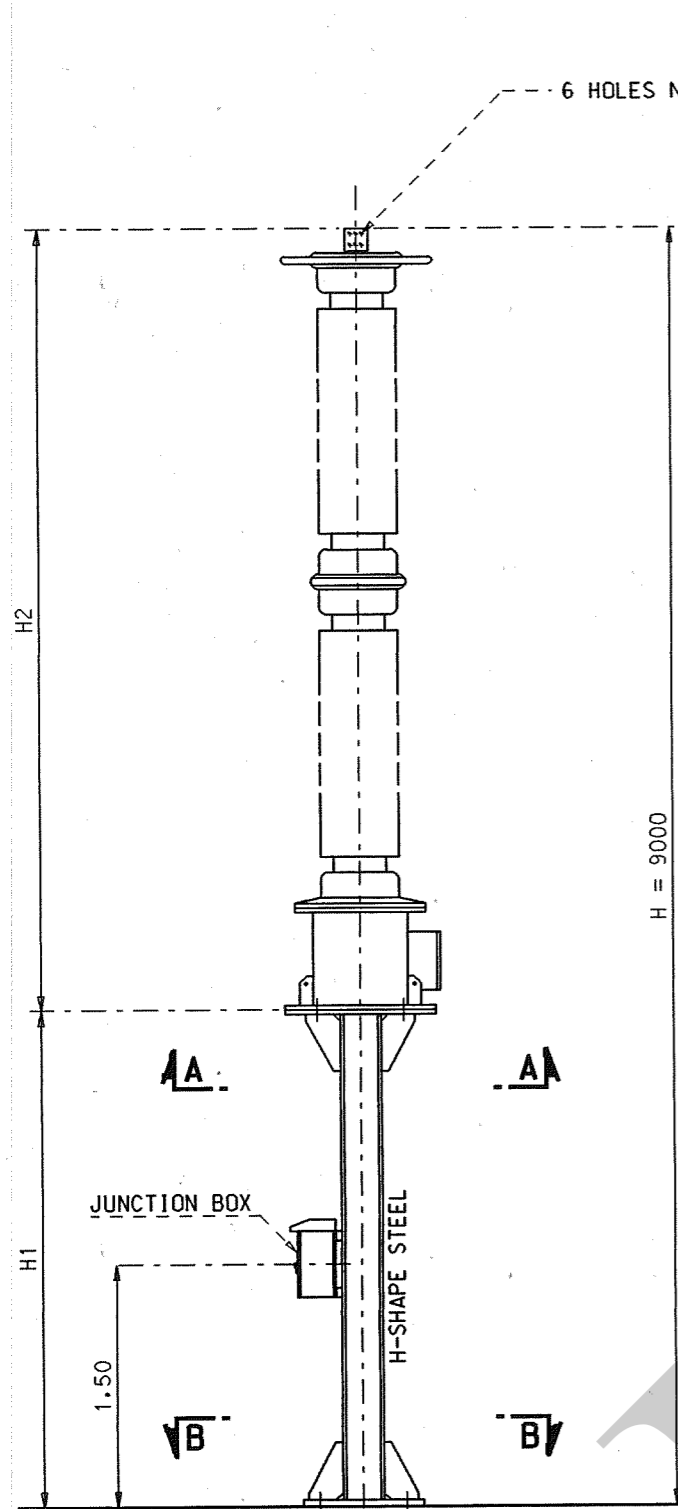

**NOTES**

1. ALL DIMENSIONS ARE IN MILLIMETERS, EXCEPT OTHERWISE SHOWN.
2. QUALITY OF MATERIALS
  - ALL MEMBERS SHALL CONFORM TO ASTM A36 OR EQUIVALENT.
  - ALL BOLTS AND NUTS SHALL CONFORM TO ASTM A394 TYPE "O" OR EQUIVALENT.
  - SPRING WASHERS SHALL BE CARBON STEEL CONFORMING TO ASA B27.1, REGULAR TYPE.
3. ALL MATERIALS SHALL BE HOT-DIP GALVANIZED AFTER FABRICATION AND CLEANING.
  - ALL MEMBERS AND PLATES SHALL CONFORM TO ASTM A123
  - ALL BOLTS AND NUTS SHALL CONFORM TO ASTM A153
4. FINISHED MATERIALS SHALL BE DIPPED INTO THE SOLUTION OF DICHROMATE AFTER GALVANIZING FOR WHITE RUST PROTECTION.
5. STANDARD GAUGE OF MEMBERS ARE HALF OF FLANGE, EXCEPT OTHERWISE SHOWN.
6. THE DIMENSION U.V.W.X.Y DEPENDING ON MANUFACTURER'S EQUIPMENT SHALL BE ASSIGNED BY THE CONTRACTOR.
7. THE DETAIL DESIGN FOR INSTALLATION OF ACCESSORIES PART OF EQUIPMENT AND STEEL STRUCTURE SHALL BE ASSIGNED BY THE CONTRACTOR.
8. DETAIL OF STANDARD BOLTS, NUTS AND ANCHOR BOLTS SEE DWG.NO.SD-AB-0-01,01/01 (REV.2).

**เอกสารไม่ควบคุม**  
 รับรองสำเนาโดย ททอ-ร.กสจ-ร.อวส.  
 ก่อนนำไปใช้งาน  
 ต้องตรวจสอบ Revision ล่าสุด  
 ฝ่ายวิศวกรรมระบบส่ง กฟผ.

31 มีนาคม 2569

CABINET NO. V1  
 RUN NO. A045

**ELECTRICITY GENERATING AUTHORITY OF THAILAND**

DRAWN P. SORNKIT	VALIDATED S. Indarat	DRAWING NAME TYPICAL DRAWING
DESIGNED Wimonwan	RECOMMENDED S. Indarat	DESCRIPTION OF DETAIL DRAWING 500KV COUPLING CAPACITOR VOLTAGE TRANSFORMER STRUCTURE
VERIFIED Wimonwan	CONCURRED S. Indarat	JOB NO. -
APPROVED J. Lj	DATE 15/02/09	REPLACING DWG. NO. -
ASSISTANT GOVERNOR - TRANSMISSION SYSTEM ENGINEERING		DWG. NO. ST-VT-9-01

REV. NO.	JOB NO.	JOB DESCRIPTION	DRAWN	DESIGNED	VERIFIED	VALIDATED	RECOMMENDED	CONCURRED	APPROVED	DATE
1	-	REVISE TERMINAL TO 6 HOLES NEMA PAD 2 ROWS x 3 COLUMNS								

ISO 9001  
 TSE-TSP 2000  
 CAD CENTER  
 DO NOT AMEND MANUALLY  
 D:\SORSKIT\ST-VT-ST-VT-9-01.DWG  
 13-FEB-2008 12:57  
 SEADMIN

TABLE FOR RING FILLERS Unit : mm RING FILLERS

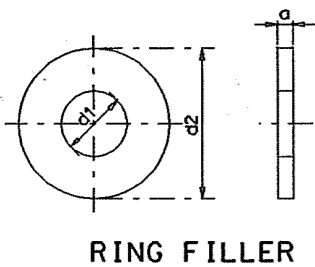

Nominal Diameter d	d1		d2	
	Nominal	Tolerance	Nominal	Tolerance
M12	13.5	+0.7 -0	30.0	+0 -1.0
M16	17.5	+0.7 -0	40.0	+0 -1.0
M20	21.5	+0.8 -0	50.0	+0 -1.0
M22	23.5	+0.8 -0	57.0	+0 -1.0
M24	25.5	+0.8 -0	65.0	+0 -1.0
M28	29.5	+0.8 -0	75.0	+0 -1.0
M32	33.5	+0.8 -0	85.0	+0 -1.0

Unit : mm

a	Tolerance
4, 5	±0.5
6	±0.7
8	±0.7
9	±0.7
12	±1.0

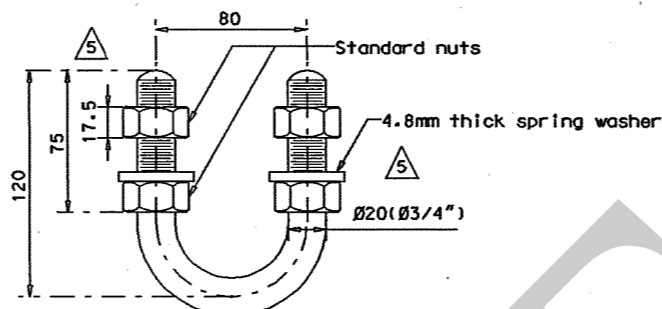

M20 U-BOLT

NOTES

- ALL DIMENSIONS ARE IN MILLIMETER, UNLESS OTHERWISE SHOWN
- ALL MATERIAL SHALL CONFORM TO THE FOLLOWING DESIGNATION OR EQUIVALENT  
 HEX. BOLT.....ASTM A394 TYPE 0  
 HEX. NUT.....ASTM A563 CLASS A  
 U-BOLT.....ASTM A394 TYPE 0 UNLESS OTHERWISE NOTED  
 SPRING WASHER.....ASTM A394 TYPE 0 UNLESS OTHERWISE NOTED.  
 RING FILLER.....JIS SS 400  
 PLAIN WASHER.....JIS SS 400  
 ANCHOR BOLTS.....A 307 CLASS C  
 STEP BOLTS.....A 307 CLASS A
- ALL MATERIALS SHALL BE HOT-DIP GALVANIZED TO MEET THE REQUIREMENT OF ASTM A 153 AFTER FABRICATION
- LENGTH OF ANCHOR SHALL BE AS SHOWN IN TABLE FOR ANCHOR BOLT UNLESS OTHERWISE SHOWN ON THE INDIVIDUAL TYPICAL DRAWING.
- COMPLETE SET OF BOLT SHALL BE AS FOLLOWING ASSEMBLY UNLESS CONNECTION BOLT.....1 BOLT, 1 NUT AND 1 SPRING WASHER  
 ANCHOR BOLT.....1 BOLT, 3 NUT AND 2 PLAIN WASHER OF 6mm. THK.  
 STEP BOLT.....1 BOLT, 2 NUT AND 1 SPRING WASHER  
 U-BOLT.....1 BOLT, 4 NUT AND 2 SPRING WASHER
- THREADS FOR STEP BOLT TO BE UNDER CUT BY 0.3mm FOR GALVANIZING
- ALL NUTS SHALL BE STANDARD HEXAGONAL.
- H=HEIGHT OF STANDARD NUT IN mm

TABLE FOR HEX NUT Unit : mm

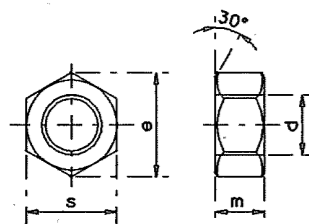

HEX NUT

Nominal Diameter d	m		s		e
	Nominal	Tolerance	Nominal	Tolerance	
M12	10.5	±0.8	18.0	+0 -0.8	20.8
M16	14.0	±0.9	24.0	+0 -0.8	27.7
M20	17.5	±0.9	30.0	+0 -0.8	34.6
M22	19.2	±0.9	32.0	+0 -1.0	38.1
M24	21.0	±1.0	36.0	+0 -1.0	41.6
M28	24.5	±1.0	42.0	+0 -1.0	48.5
M32	28.0	±1.0	48.0	+0 -1.0	55.4
M36	31.5	±1.0	54.0	+0 -1.2	62.4
M39	34.1	±1.2	58.5	+0 -1.2	67.6
M42	36.1	±1.2	63.0	+0 -1.2	72.7
M60	52.5	±1.2	90.0	+0 -1.4	103.9

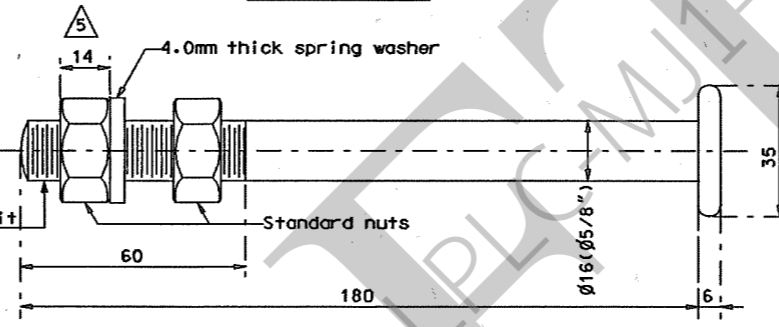

M16 STEP BOLT

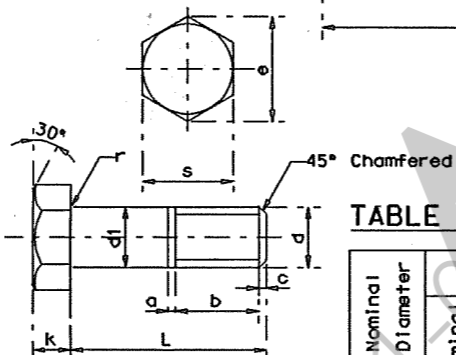

HEX BOLT

TABLE FOR HEX BOLTS (JIS) Unit : mm

Nominal Diameter d	d1		k		s		e	r	c	a	b		L (tolerance)	
	Nominal	Tolerance	Nominal	Tolerance	Nominal	Tolerance					Nominal	Tolerance	Upto 50	Over 50 upto 120
M12	12.0	+0.9 -0.2	8.0	±0.8	19.0	+0 -0.8	21.9	0.6	2.0	2.0	19.5	+1.0 -0	±1.0	±1.4
M16	16.0	+0.9 -0.2	10.0	±0.8	24.0	+0 -0.8	27.7	0.6	2.0	2.0	22.0	+1.0 -0	±1.0	±1.4
M20	20.0	+0.95 -0.35	13.0	±0.9	30.0	+0 -0.8	34.6	0.8	2.5	2.5	26.5	+1.0 -0	±1.0	±1.4
M24	24.0	+0.95 -0.35	15.0	±0.9	36.0	+0 -1.0	41.6	0.8	2.5	3.0	34.0	+1.0 -0	±1.0	±1.4
M28	28.0	+0.95 -0.35	18.0	±0.9	42.0	+0 -1.0	48.3	1.0	2.5	3.0	40.5	+1.0 -0	±1.0	±1.4
M32	32.0	+1.20 -0.40	21.0	±1.0	50.0	+0 -1.0	57.7	1.0	2.5	3.5	47.0	+1.0 -0	±1.0	±1.4

TABLE FOR HEX BOLTS (ANSI) Unit : mm

Nominal Diameter d	d1		k		s		e	r	c	a	b		L (tolerance)	
	Nominal	Tolerance	Nominal	Tolerance	Nominal	Tolerance					Nominal	Tolerance	Upto 50	Over 50 upto 120
M12	12.0	+0.9 -0.2	8.2	±0.8	17.7	+0 -0.8	23.0	0.6	2.0	2.0	19.5	+1.0 -0	±1.0	±1.4
M16	16.0	+0.9 -0.2	10.1	±0.8	24.0	+0 -0.8	27.1	0.6	2.0	2.0	22.0	+1.0 -0	±1.0	±1.4
M20	20.0	+0.95 -0.35	13.0	±0.9	30.0	+0 -0.8	33.9	0.8	2.5	2.5	26.5	+1.0 -0	±1.0	±1.4
M22	22.0	+0.95 -0.35	14.6	±1.1	33.0	+0 -0.8	37.3	0.8	2.5	2.5	30.0	+1.0 -0	±1.0	±1.4
M24	24.0	+0.95 -0.35	17.0	±1.3	36.0	+0 -0.8	40.6	0.8	2.5	2.5	34.0	+1.0 -0	±1.0	±1.4
M28	28.0	+0.95 -0.35	18.8	±1.5	40.0	+0 -0.8	47.4	0.8	2.5	2.5	40.5	+1.0 -0	±1.0	±1.4
M32	32.0	+0.95 -0.35	21.5	±1.6	43.4	+0 -0.8	54.2	0.8	2.5	2.5	47.0	+1.0 -0	±1.0	±1.4

TABLE FOR SPRING LOCK WASHERS (JIS) Unit : mm

Nominal Diameter d	d1		d2		s	
	Nominal	Tolerance	Max.	Min.	Min.	Min.
M12	12.2	+0.6 -0	21.5	4.2	3.0	
M16	16.2	+0.8 -0	28.0	5.2	4.0	
M20	20.2	+0.8 -0	33.8	6.1	5.1	
M24	24.5	+1.0 -0	40.3	7.1	5.9	
M28	28.2	+1.2 -0	46.3	8.2	7.0	
M32	32.2	+1.4 -0	53.7	9.1	8.0	

TABLE FOR SPRING LOCK WASHERS (ANSI) Unit : mm

Nominal Diameter d	d1		d2		s	
	Nominal	Tolerance	Max.	Min.	Min.	Min.
M12	12.2	+0.8 -0	21.5	4.3	3.2	
M16	16.2	+0.8 -0	27.6	5.2	4.0	
M20	20.2	+0.8 -0	33.3	6.0	4.8	
M22	22.2	+0.8 -0	36.5	6.6	5.4	
M24	24.2	+0.8 -0	39.8	7.2	5.9	
M28	28.2	+0.8 -0	46.2	8.3	7.0	
M32	32.2	+0.8 -0	52.5	9.3	8.1	

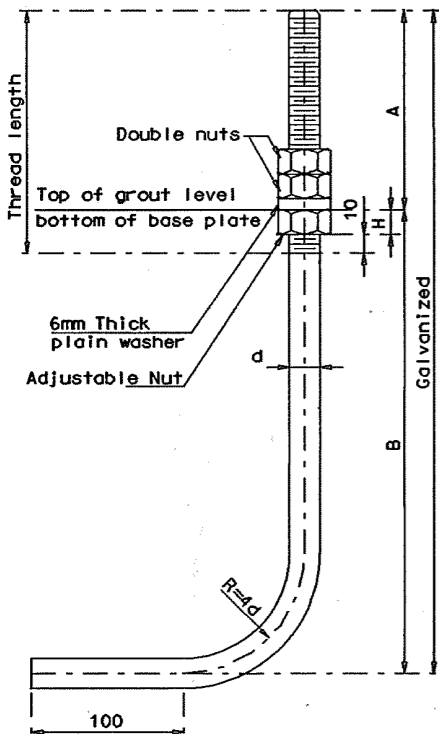

ANCHOR BOLT DETAIL

TABLE FOR ANCHOR BOLTS

Anchor bolt size (mm)	Diameter d (mm)	A (mm)	Embedded Length B (mm)	Nut width H (mm)	Radius R (mm)
M 16x555x100 128mm Thread length	16	105	450	13	64
M 20x712x100 138mm Thread length	20	112	600	16	80
M 22x818x100 146mm Thread length	22	118	700	18	88
M 25x924x100 (OR M24) 153mm Thread length	24 25	124	800	19	100
M 28x1036x100 168mm Thread length	28	136	900	22	112
M 32x1142x100 178mm Thread length	32	142	1000	26	128
M 35x1253x100 192mm Thread length	35	153	1100	29	140
M 38x1357x100 198mm Thread length	38	157	1200	31	152
M 42x1427x100 221mm Thread length	42	177	1250	34	168
M 45x1585x100 231mm Thread length	45	185	1400	36	180
M 60x2142x100 250mm Thread length	60	192	1950	48	240

เอกสารไม่ควบคุม  
 รับรองสำเนาโดย พท.ร. กฤษ...  
 ก่อนนำไปใช้งาน  
 ต้องตรวจสอบ Revision ที่สุด  
 ฝ่ายวิศวกรรมระบบส่ง กฟผ.

CABINET NO. V5  
 RUN NO. 1601

REV. NO.	JOB NO.	JOB DESCRIPTION	DRAWN	DESIGNED	VERIFIED	VALIDATED	RECOMMENDED	CONCURRED	APPROVED	DATE
7	-	Revised size of Nut & Washers	P. PEEARAWAT	P. LERWATE	-	-	-	-	-	-
6	-	Add JIS Hex bolts and spring washers tables	P. PEEARAWAT	P. LERWATE	-	-	-	-	-	23/9/2553
5	-	Add size of M45 anchor bolt and revise notes and illustrations	P. PEEARAWAT	P. LERWATE	-	-	-	-	-	8/9/2552
4	-	Add details of M22 hex bolt and spring lock washer and revise drawing as per ANSI standards	P. PEEARAWAT	P. LERWATE	-	-	-	-	-	19/6/2552
3	-	Additional sizes of ring filler, hex nut, hex bolt, and spring washer	P. PEEARAWAT	P. LERWATE	-	-	-	-	-	12/6/2551

**ELECTRICITY GENERATING AUTHORITY OF THAILAND**

STANDARD DRAWING

DESCRIPTION OF DETAIL DRAWING: DETAILS OF STANDARD BOLTS, NUTS, RING FILLERS, SPRING LOCK WASHERS

DATE: 17/10/14